

HDM

HIGH TORQUE DENSITY SERVOMOTORS



TECHNICAL DATA MANUAL ISSUE NO. 5.4

Date: June 2011



SEM Limited
Faraday Way
Orpington, KENT
BR5 3QT
United Kingdom

Tel: +44 (0)1689 884 700
Fax: +44 (0)1689 884 884
Email: sales@sem.co.uk
Internet: www.sem.co.uk

CONTENTS

- 1** Introduction
- 2** General information
 - Receiving and storage.
 - Environmental protection.
 - Mounting of motors.
 - Thermal protection.
 - Maintenance and servicing.
 - Holding brake options
 - E.U. Directives.
- 3** Mechanical tolerance
- 4** Connection details
- 5** Feedback device specification
- 6** Torque derating at high temperatures
- 7** HDM58 Technical Information
- 8** HDM82 Technical Information
- 9** HDM105 Technical Information
- 10** HDM142 Technical Information
- 11** Useful Formulae

INTRODUCTION

SEM has continuously developed its range of servo products to best serve the latest industry requirements. The new HDM range of servomotors uses the long experience gained in the servomotor field to give cost effective performance.

The HDM range has been specifically designed to provide optimal performance whilst remaining compact and cost effective. The high torque to inertia ratio allows fast acceleration and deceleration and rapid dynamic response.

These motors are ideally suited for any high dynamic application where space constraints apply.

WHY BRUSHLESS?

The optimum performance of a brushless servomotor is achievable without danger of commutator "flashover".

Speeds of up to 10000 rpm are possible.

SEM brushless servomotors are fitted with available with high flux density Neodymium Iron Boron magnets reducing rotor inertia and allowing higher peak torques for acceleration and deceleration.

As the winding is stationary, we have been able to position the thermal sensor here where it is most effective. By using this thermal sensor, the risk of overheating or demagnetising a brushless servomotor can be virtually eliminated.

The motors are virtually maintenance free.

GENERAL INFORMATION

RECEIVING AND STORAGE

On receipt the motors should be inspected. Any damage found should be reported immediately to SEM and the carrier.

ENVIRONMENTAL PROTECTION

All SEM brushless motors are protected to IP65 except at the shaft where the protection is IP64 with a shaft seal fitted.

Protection Class	Description
IP65	Totally protected against dust. Protected against low pressure jets of water from all directions with limited ingress permitted
IP64	Totally protected against dust. Protected against water sprayed from all directions with limited ingress permitted

MOUNTING OF MOTORS

Where a toothed belt is proposed, the motors should be flange mounted to an angle bracket or similar as close as possible to the line of action of the drive. The motor pulley should be positioned as close as possible to the mounting face and the pulley diameter chosen to maintain dynamic shaft loading within the limits indicated on the loading graphs. Particular attention must be given to the tension of the drive belts, with reference to the belt manufacturers instructions so that unnecessarily high shaft loads are avoided on installation. **If the belt tension is too high, the bearings may be damaged and in extreme cases, the shaft may break.**

THERMAL PROTECTION

HDM servomotors are fitted with a Philips type KTY84-130 thermal sensor. The resistance of this sensor varies with temperature as indicated below.

Resistance change with temperature	
Temperature °C	Resistance Ω
0	474 to 522
25	577 to 629
100	970 to 1030
150	1282 to 1385
160	1350 to 1463

The current in the sensor should be between 1mA and 3mA.

To protect the winding, the drive should shut down if the resistance exceeds 1400 Ohms.

GENERAL INFORMATION

MAINTENANCE AND SERVICING

BEARINGS

All HDM servomotors are fitted with double shielded, single row radial ball bearings. Under normal conditions, no maintenance is required.

Bearing Specification		
Frame	ISO Code for Drive End	ISO Code for Non-Drive End
HDM58	6002 2Z	6900 2Z
HDM82	6002 2Z	6002 2Z
HDM105	6004 2Z	6003 2Z
HDM142	6205 2Z	6004 2Z

The bearings are selected to give a minimum of 30,000 hours life. Refer to the shaft loading graphs for further information.

MECHANICAL

It is recommended that a general inspection be made at regular intervals to check all bolts, nuts couplings etc to ensure that they are still tightened to the correct torque.

Fitting and Tightening Motor Drive End to Body Fasteners		
Frame	Screw Size	Torque
HDM58	N/A single piece drive end / body	
HDM82	M4	2.2
HDM105	M5	5.0
HDM42	M6	8.0

For information on the repair and rectification of brushless servomotors please contact SEM.

GENERAL INFORMATION

HOLDING BRAKES

HOLDING BRAKE OPTIONS

All brakes used on the HDM motors are constructed such that when in the power off state (brake engaged condition) the brake friction plate is forced into frictional contact with the rigidly fixed brake housing thus preventing the friction plate from rotating.

These are primarily a holding brake e.g. to hold a load under a no voltage condition. However, the brake can also be used in some applications for emergency stopping.

Connection should be such that when the motor is powered the brake is energized and the brake released. Under normal conditions, no maintenance is required other than ensuring that the hub and stationary plates are kept free from foreign matter.

Standard Ratings

Frame	Type of Brake	Brake holding torque Nm	DC Voltage V	Nominal Power Consumed W	Standard Option
HDM58A+C	Spring Applied	1.0Nm	24Vdc \pm 10%	7W \pm 7%	Yes
HDM58E+G	Permanent Magnet	2.0Nm	24Vdc \pm 10%	11W \pm 7%	Yes
HDM82	Spring Applied	4.5Nm	24Vdc \pm 10%	10.4W \pm 7%	Yes
HDM105	Spring Applied	10Nm	24Vdc \pm 10%	16W \pm 7%	Yes
HDM142	Spring Applied	20Nm	24Vdc \pm 10%	25W \pm 7%	Yes

Other brake options available on request.

E.U. DIRECTIVES

There are three main directives that affect applications incorporating servomotors.

MACHINERY DIRECTIVE 2006/42/EC

This directive applies to complete machines and SEM HDM servomotors are therefore exempt.

LOW VOLTAGE DIRECTIVE 2006/95/EC

This applies to all electrical equipment for use with a DC voltage of 75V to 1500V and AC voltage from 50V to 1000V.

HDM brushless servomotors in the ranges, HDM58, HRDM82, HDM105 and HDM142 conform to the EC directive.

A certificate of conformity is available from SEM sales on request

EMC DIRECTIVE (ELECTRO MAGNETIC COMPATIBILITY) 2004/108/EC

The directive applies to products or appliances with an intrinsic function for the end user in which:

- a. They contain electrical / electronic systems liable to cause an electromagnetic disturbance.
- b. They contain electrical / electronic systems which may have their performance affected by an electromagnetic disturbance.

SEM can provide datasheets outlining the EMC characteristics of a standard AC brushless servomotor and giving advice on cable screening connectors and other related subjects.

SEM will be pleased to discuss any EMC related problems encountered by customers incorporating SEM AC servomotors into such products or appliances, which are governed by the EMC directive.

MECHANICAL TOLERANCE

SHAFT AND SPIGOT CHECKING CHART (BASED ON IEC72)

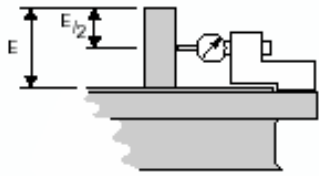

SHAFT EXTENSION RUN-OUT

SHAFT DIAMETER	NORMAL CLASS		PRECISION CLASS	
	mm	inch	mm	inch
≤10	.030	.00181	.015	.00059
>10 ≤18	.035	.00138	.018	.00071
>18 ≤30	.040	.00157	.021	.00082
>30 ≤50	.050	.00196	.025	.00098
>50 ≤80	.060	.00236	.030	.00181

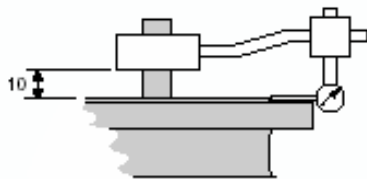

CONCENTRICITY OF SPIGOT AND SHAFT

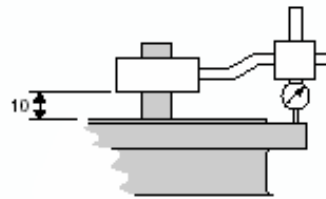

PERPENDICULARITY OF MOUNTING FACE TO SHAFT

HDM MOTOR RANGE	SPIGOT DIAMETER	MAXIMUM PERMISSIBLE CHANGE IN INDICATOR READING			
		NORMAL CLASS		PRECISION CLASS	
		mm	inch	mm	inch
58	40				
82	80	.08	.00315	.04	.00157
105	95				
142	130	.10	.00394	.05	.00197

CONNECTION DIAGRAM

HDM58 MOTORS FITTED WITH RESOLVER AND M17 CONNECTORS

SUPPLY CONNECTOR

PIN	FUNCTION
1	MOTOR U
2	MOTOR V
3	
4	BRAKE B+ (IF FITTED)
5	BRAKE B- (IF FITTED)
6	MOTOR W
⊥	EARTH

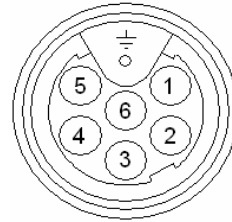

M17 CONNECTOR
7 PIN

FEEDBACK CONNECTOR

PIN	FUNCTION
1	STATOR 2 ND PHASE S2
2	STATOR 2 ND PHASES4
3	
4	
5	
6	
7	ROTOR R2
8	
9	
10	ROTOR R1
11	STATOR 1 ST PHASE S1
12	STATOR 1 ST PHASE S3
13	
14	
15	
16	
17	

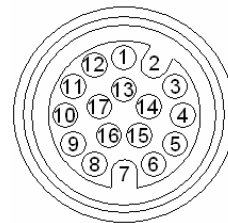

M17 CONNECTOR
17 PIN

Note that connectors are
viewed from customer side

AS SEM WIRING DIAGRAM 323-1-51281

CONNECTION DIAGRAM

HDM58 MOTORS FITTED WITH RENCO R35I ENCODER AND M17 CONNECTORS

SUPPLY CONNECTOR

PIN	FUNCTION
1	MOTOR U
2	MOTOR V
3	
4	BRAKE B+ (IF FITTED)
5	BRAKE B- (IF FITTED)
6	MOTOR W
⊥	EARTH

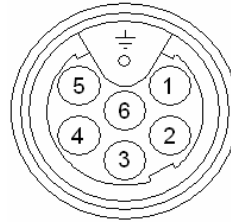

M17 CONNECTOR
7 PIN

FEEDBACK CONNECTOR

PIN	FUNCTION
1	B (ENC 2)
2	B- (NOT ENC 2)
3	Z (ENC 0)
4	W (POS SIG C)
5	U- (POS SIG NOT C)
6	U (POS SIG C)
7	GROUND (0V)
8	
9	
10	VCC (DC +5V)
11	A (ENC 1)
12	A- (NOT ENC 1)
13	Z- (NOT ENC 0)
14	W- (POS SIG NOT A)
15	V (POS SIG NOT B)
16	V- (POS SIG B)
17	

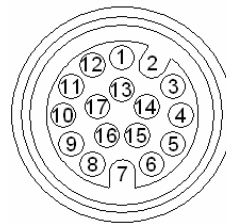

M17 CONNECTOR
17 PIN

Note that connectors are
viewed from customer side

AS SEM WIRING DIAGRAM 323-1-51280

CONNECTION DIAGRAM

HDM82 MOTORS FITTED WITH RESOLVER, M23 POWER AND M17 FEEDBACK CONNECTORS

SUPPLY CONNECTOR

PIN	FUNCTION
1	MOTOR U
2	MOTOR V
4	BRAKE B+ (IF FITTED)
5	BRAKE B- (IF FITTED)
6	MOTOR W
⊕	EARTH

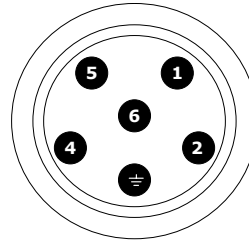

M23 CONNECTOR
6 PIN

FEEDBACK CONNECTOR

PIN	FUNCTION
1	STATOR 2 ND PHASE S2
2	STATOR 2 ND PHASES4
3	
4	
5	
6	
7	ROTOR R2
8	THERMAL SENSOR K1+ (IF FITTED)
9	THERMAL SENSOR K2- (IF FITTED)
10	ROTOR R1
11	STATOR 1 ST PHASE S1
12	STATOR 1 ST PHASE S3
13	
14	
15	
16	
17	

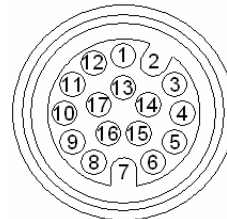

M17 CONNECTOR
17 PIN

Note that connectors are
viewed from customer side

As SEM wiring diagram 323-1-51281

CONNECTION DIAGRAM

HDM82 MOTORS FITTED WITH RENCO R35I ENCODER, M23 POWER AND M17 CONNECTORS

SUPPLY CONNECTOR

PIN	FUNCTION
1	MOTOR U
2	MOTOR V
4	BRAKE B+ (IF FITTED)
5	BRAKE B- (IF FITTED)
6	MOTOR W
⊕	EARTH

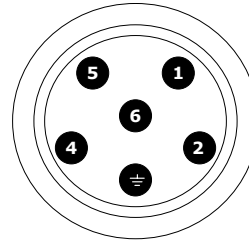

M23 CONNECTOR
6 PIN

FEEDBACK CONNECTOR

PIN	FUNCTION
1	B (ENC 2)
2	B- (NOT ENC 2)
3	Z (ENC 0)
4	W (POS SIG C)
5	U- (POS SIG NOT C)
6	U (POS SIG C)
7	GROUND (0V)
8	THERMAL SENSOR K1+ (IF FITTED)
9	THERMAL SENSOR K2 - (IF FITTED)
10	VCC (DC +5V)
11	A (ENC 1)
12	A- (NOT ENC 1)
13	Z- (NOT ENC 0)
14	W- (POS SIG NOT A)
15	V (POS SIG NOT B)
16	V- (POS SIG B)
17	

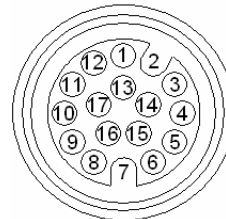

M17 CONNECTOR
17 PIN

Note that connectors are viewed from customer side

CONNECTION DIAGRAM

HDM82, 105 AND 142 MOTORS FITTED WITH RESOLVER AND M23 CONNECTORS

SUPPLY CONNECTOR

PIN	FUNCTION
1	MOTOR U
2	MOTOR V
4	BRAKE B+ (IF FITTED)
5	BRAKE B- (IF FITTED)
6	MOTOR W
⊕	EARTH

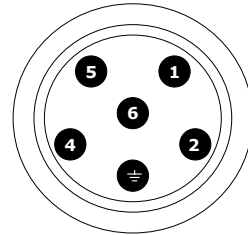

M23 CONNECTOR
6 PIN

FEEDBACK CONNECTOR

PIN	FUNCTION
1	STATOR 2 ND PHASE S2
2	STATOR 2 ND PHASES4
3	
4	
5	
6	
7	ROTOR R2
8	THERMAL SENSOR K1+ (IF FITTED)
9	THERMAL SENSOR K2- (IF FITTED)
10	ROTOR R1
11	STATOR 1 ST PHASE S1
12	STATOR 1 ST PHASE S3

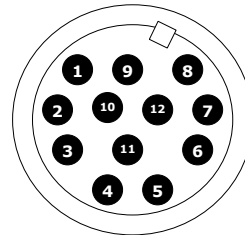

M23 CONNECTOR
12 PIN (20° OFFSET)

Note that connectors are viewed from customer side

AS SEM WIRING DIAGRAM 323-1-48995

CONNECTION DIAGRAM

HDM82, 105 AND 142 MOTORS FITTED WITH RENCO R35I ENCODER AND M23 CONNECTORS

SUPPLY CONNECTOR

PIN	FUNCTION
1	MOTOR U
2	MOTOR V
4	BRAKE B+ (IF FITTED)
5	BRAKE B- (IF FITTED)
6	MOTOR W
⊕	EARTH

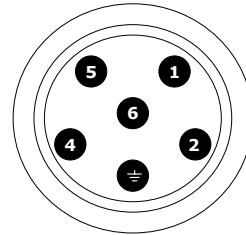

M23 CONNECTOR
6 PIN

FEEDBACK CONNECTOR

PIN	FUNCTION
1	B (ENC 2)
2	B- (NOT ENC 2)
3	Z (ENC 0)
4	W (POS SIG C)
5	U- (POS SIG NOT C)
6	U (POS SIG C)
7	GROUND (0V)
8	THERMAL SENSOR K1+ (IF FITTED)
9	THERMAL SENSOR K2 - (IF FITTED)
10	VCC (DC +5V)
11	A (ENC 1)
12	A- (NOT ENC 1)
13	Z- (NOT ENC 0)
14	W- (POS SIG NOT A)
15	V (POS SIG NOT B)
16	V- (POS SIG B)
17	

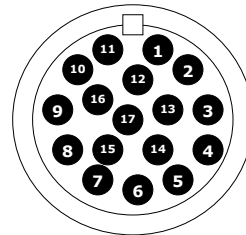

M23 CONNETTOR
17 PIN

Note that connectors are
viewed from customer side

As SEM wiring diagram 323-1-51077

CONNECTION DIAGRAM

HDM82, 105 AND 142 MOTORS FITTED WITH HEIDENHAIN ERN1185/1387 ENCODER AND M23 CONNECTORS

SUPPLY CONNECTOR

PIN	FUNCTION
1	MOTOR U
2	MOTOR V
4	BRAKE B+ (IF FITTED)
5	BRAKE B- (IF FITTED)
6	MOTOR W
⊕	EARTH

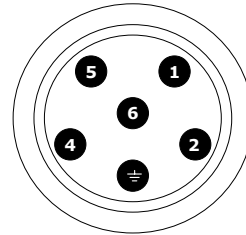

M23 CONNECTOR
6 PIN

FEEDBACK CONNECTOR

PIN	FUNCTION
1	A+ (0° SIGNAL)
2	A- (0° SIGNAL)
3	R+ (REF SIGNAL)
4	D- (COSINUS)
5	C+ (SINUS)
6	C- (COSINUS)
7	0V (UN)
8	THERMAL SENSOR K1+ (IF FITTED)
9	THERMAL SENSOR K2- (IF FITTED)
10	+5V (UP)
11	B+ (90° SIGNAL)
12	B- (90° SIGNAL)
13	R- (REF SIGNAL)
14	D+ (COSINUS)
15	0V (SENSOR UN)
16	+5V (SENSOR UP)
17	

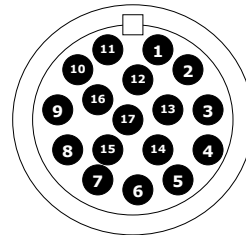

M23 CONNECTOR
17 PIN

Note that connectors are
viewed from customer side

AS SEM WIRING DIAGRAM 323-1-48891

CONNECTION DIAGRAM

HDM82, 105 AND 142 MOTORS FITTED WITH HEIDENHAIN ENDAT ENCODER AND M23 CONNECTORS

SUPPLY CONNECTOR

PIN	FUNCTION
1	MOTOR U
2	MOTOR V
4	BRAKE B+ (IF FITTED)
5	BRAKE B- (IF FITTED)
6	MOTOR W
⊕	EARTH

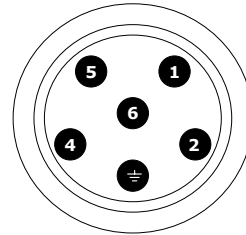

M23 CONNECTOR
6 PIN

FEEDBACK CONNECTOR

PIN	FUNCTION
1	A+ (0° SIGNAL)
2	A- (0° SIGNAL)
3	DATA +
4	
5	CLOCK +
6	
7	0V (UN)
8	THERMAL SENSOR K1+ (IF FITTED)
9	THERMAL SENSOR K2- (IF FITTED)
10	+5V (UP)
11	B+ (90° SIGNAL)
12	B- (90° SIGNAL)
13	DATA -
14	CLOCK -
15	0V (SENSOR UN)
16	+5V (SENSOR UP)
17	

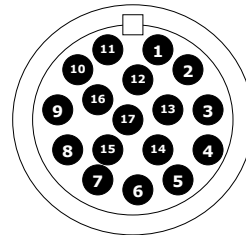

M23 CONNECTOR
17 PIN

Note that connectors are
viewed from customer side

AS SEM WIRING DIAGRAM 323-1-49747

CONNECTION DIAGRAM

HDM82, 105 AND 142 MOTORS FITTED WITH STEGMANN SRS50/SRM50 ENCODER AND M23 CONNECTORS

SUPPLY CONNECTOR

PIN	FUNCTION
1	MOTOR U
2	MOTOR V
4	BRAKE B+ (IF FITTED)
5	BRAKE B- (IF FITTED)
6	MOTOR W
⊕	EARTH

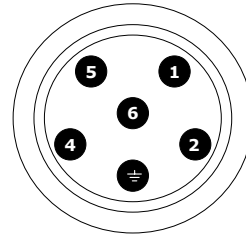

M23 CONNECTOR
6 PIN

FEEDBACK CONNECTOR

PIN	FUNCTION
1	SIN +
2	REFSIN
3	+485
4	
5	
6	
7	GROUND
8	THERMAL SENSOR K1+ (IF FITTED)
9	THERMAL SENSOR K2- (IF FITTED)
10	+V
11	COS +
12	REFCOS
13	-485
14	
15	
16	
17	

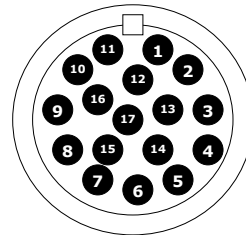

M23 CONNECTOR
17 PIN

Note that connectors are
viewed from customer side

AS SEM WIRING DIAGRAM 323-1-49646

FEEDBACK DEVICE SPECIFICATION

SPECIFICATION FOR RESOLVER SIZE 15

Fitted to SEM HDM motors

Configuration: 2 pole (1speed), brushless resolver.

Input to single phase rotor.

Output from 2 phase stator

Connections and output equation: *see drawing*

DATA	Primary Side	R1-R2	
	Pole Pairs	1	
	Transformation Ratio	0.5 ± 0.05	
	Input Voltage	7V _{rms}	7V _{rms}
	Input Current	58mA	36mA
	Input Frequency	5 kHz	10kHz
	Phase Shift (± 3°)	8°	-6°
	Impedance		
	Z _{ro}	75 j 98 Ohm	110 j 159 Ohm
	Z _{so}	180 j 230 Ohm	245 j 400 Ohm
	Z _{ss}	170 j 200 Ohm	216 j 370 Ohm
	DC resistances		
	Rotor	40 Ohm ± 10%	
	Stator	102 Ohm ± 10%	
	Null Voltage	30 mV max	
Accuracy	± 10'		
Approved resolver	LTN RE15-1-A84		

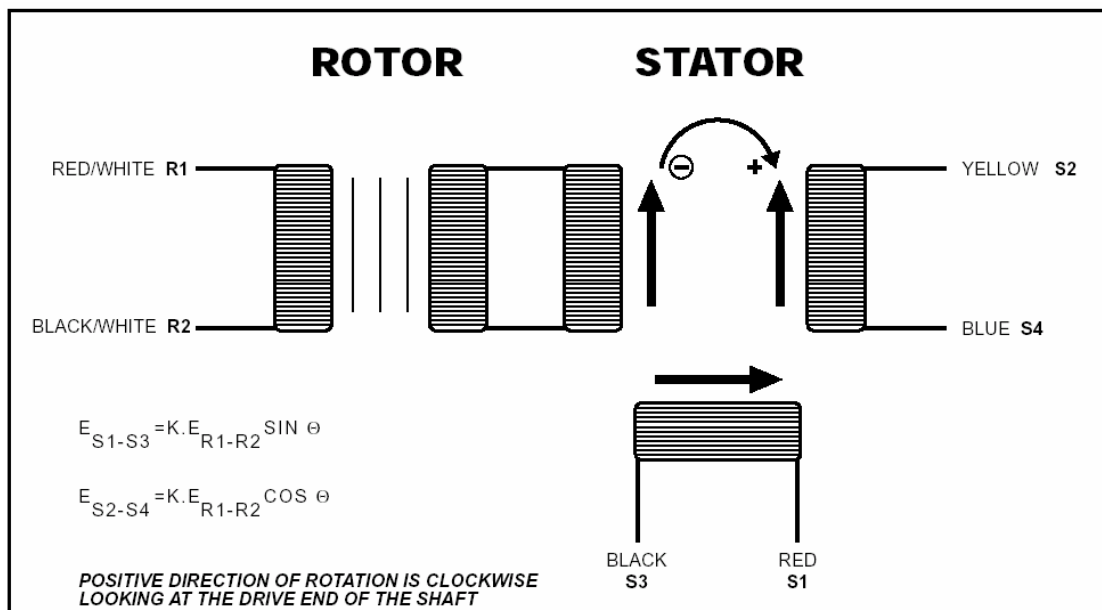

FEEDBACK DEVICE SPECIFICATION

SEM'S STANDARD RESOLVER SETTINGS

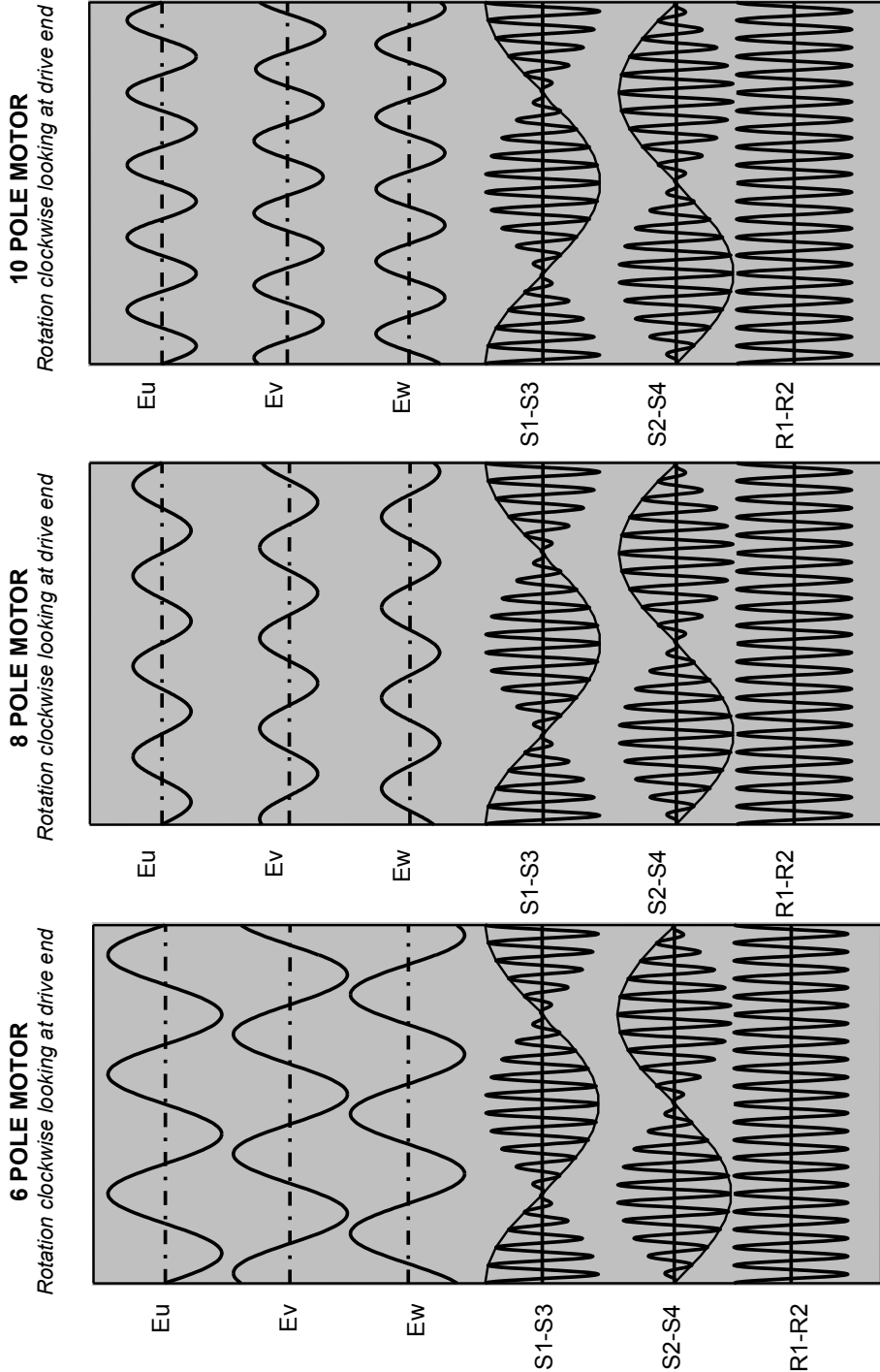

NOTES

- 1 Clockwise rotation means that the shaft rotates clockwise looking at the drive end of the shaft.
- 2 The EMFs (Eu, Ev, Ew) are phase EMFs
- 3 For + VE current into the motor; Iu, in phase with Eu will give a clockwise torque (motoring)

FEEDBACK DEVICE SPECIFICATION

SPECIFICATION FOR RENCO ENCODER TYPE R35i

Fitted to SEM HDM motors

Configuration: Square wave two channel quadrature with index and commutation signals

DATA	Electrical Resolutions available	
	Line Counts	2048, 4096, 8192
	Input	
	Supply voltage	5.0 VDC \pm 10% Single Supply
	Nominal power requirements	175mA
	Output	
	Frequency Response	500KHz (1x)
	Output Logic Levels	"1" 2.5 VDC Min "0" 0.5VDC Max
	Output Format	LD (Line driver) TI 26C31IDBR typical output 26C32 typical line receiver suggested for user interface

Encoder, LD output

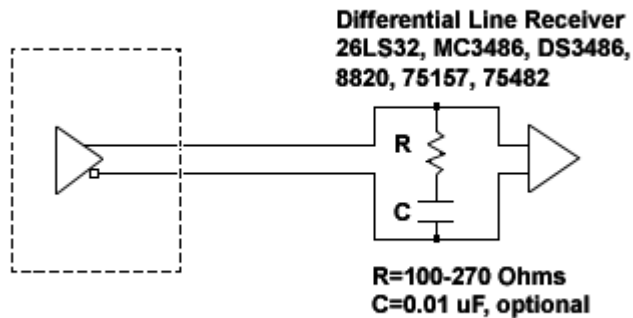

FEEDBACK DEVICE SPECIFICATION

RENCO R35i TTL INCREMENTAL ENCODER—INCREMENTAL SIGNALS

Rotation clockwise looking at drive end

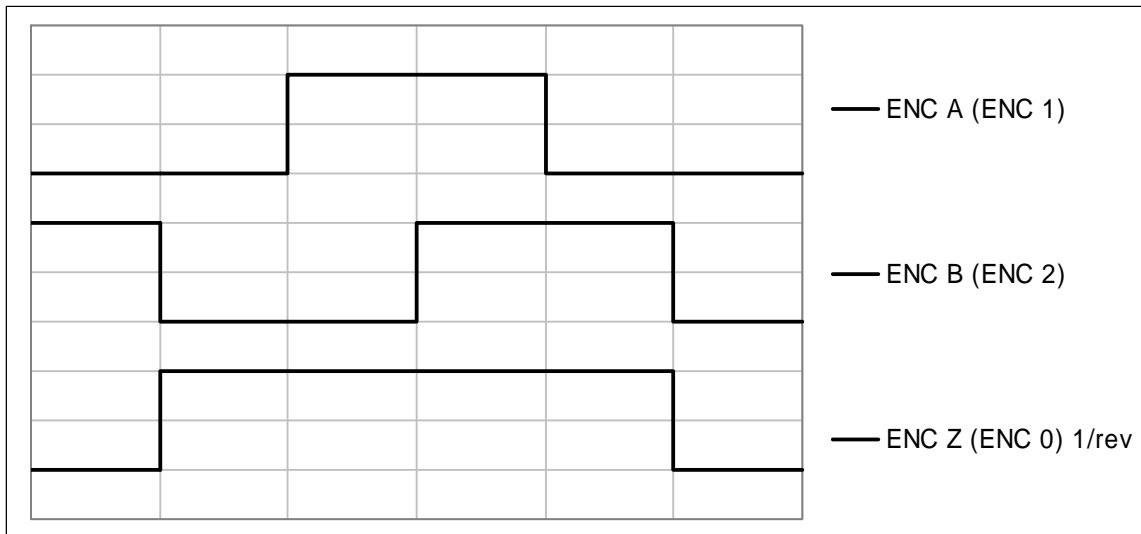

NOTES

NOT A leads NOT C and NOT C leads B.

NOT A lines up with motor line to line emf MOTOR U-V.

The ENC 0 signal occurs once per revolution.

For SEM's standard setting, the ENC 0 signal occurs at the falling edge of NOT C.

The width of the ENC 0 signal is 1 +/-0.5 incremental signal cycles.

Incremental signal ENC 1 leads ENC 2.

For SEM's standard setting (ENC 0 signal at the falling edge of NOT C), the correlation between SEM and encoder manufacturers' signal names is as follows

SEM	Renco R35i
NOT A	W-
NOT C	U-
B	V-
A	W
C	U
NOT B	V
ENC 1	A
ENC 2	B
ENC 0	Z
NOT ENC 1	A-
NOT ENC 2	B-
NOT ENC 0	Z-

For other settings (alternative positions of ENC 0) the correlation between SEM and encoder manufacturers' signal names will be different

FEEDBACK DEVICE SPECIFICATION

RENCO R35i TTL INCREMENTAL ENCODER-COMMUTATION SIGNALS

(Note that some customers specify alternative settings)

Rotation clockwise looking at drive end

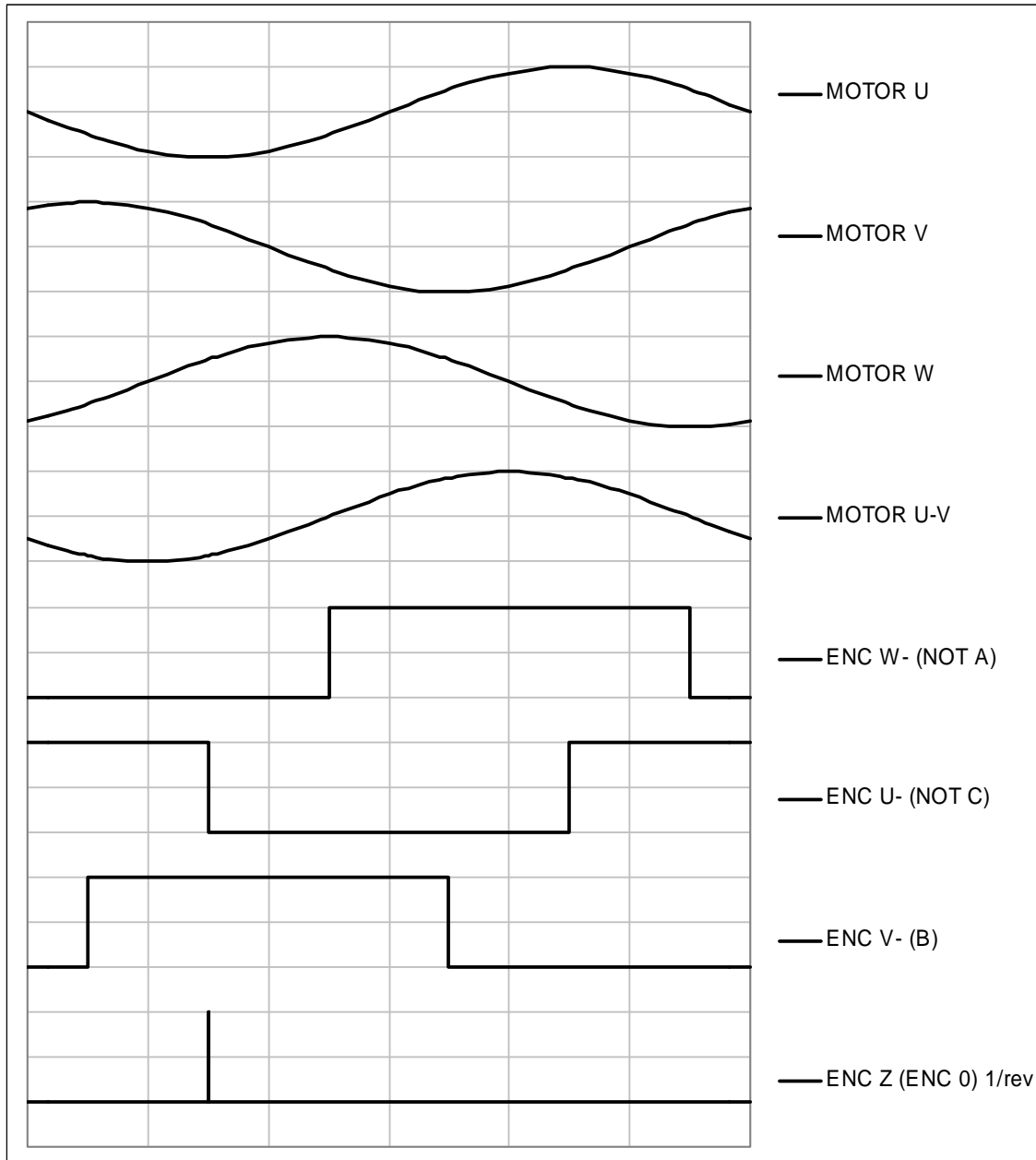

NOTES

- 1 Clockwise rotation means that the shaft rotates clockwise looking at the drive end of the shaft.
- 2 The EMFs (E_u , E_v , E_w) are phase EMFs
- 3 For + VE current into the motor; I_u , in phase with E_u will give a clockwise torque (motoring)

SEM TTL INCREMENTAL ENCODER SIGNAL SPEC

NOT A leads NOT C and NOT C leads B.

NOT A lines up with motor line to line emf MOTOR U-V.

The ENC 0 signal occurs once per revolution.

The width of the ENC 0 signal is 1 ± 0.5 incremental signal cycles.

Incremental signal ENC 1 leads ENC 2.

ADDITIONAL DETAILS FOR SEM'S STANDARD SETTING

The ENC 0 signal occurs at the falling edge of NOT C.

Renco R35i: U = SEM C; V = NOT B; W = A

DERATING OF SEM MOTORS WITH NdFeB MAGNETS for unusual ambient temperatures

Note that the peak current must be reduced as well as the rated current

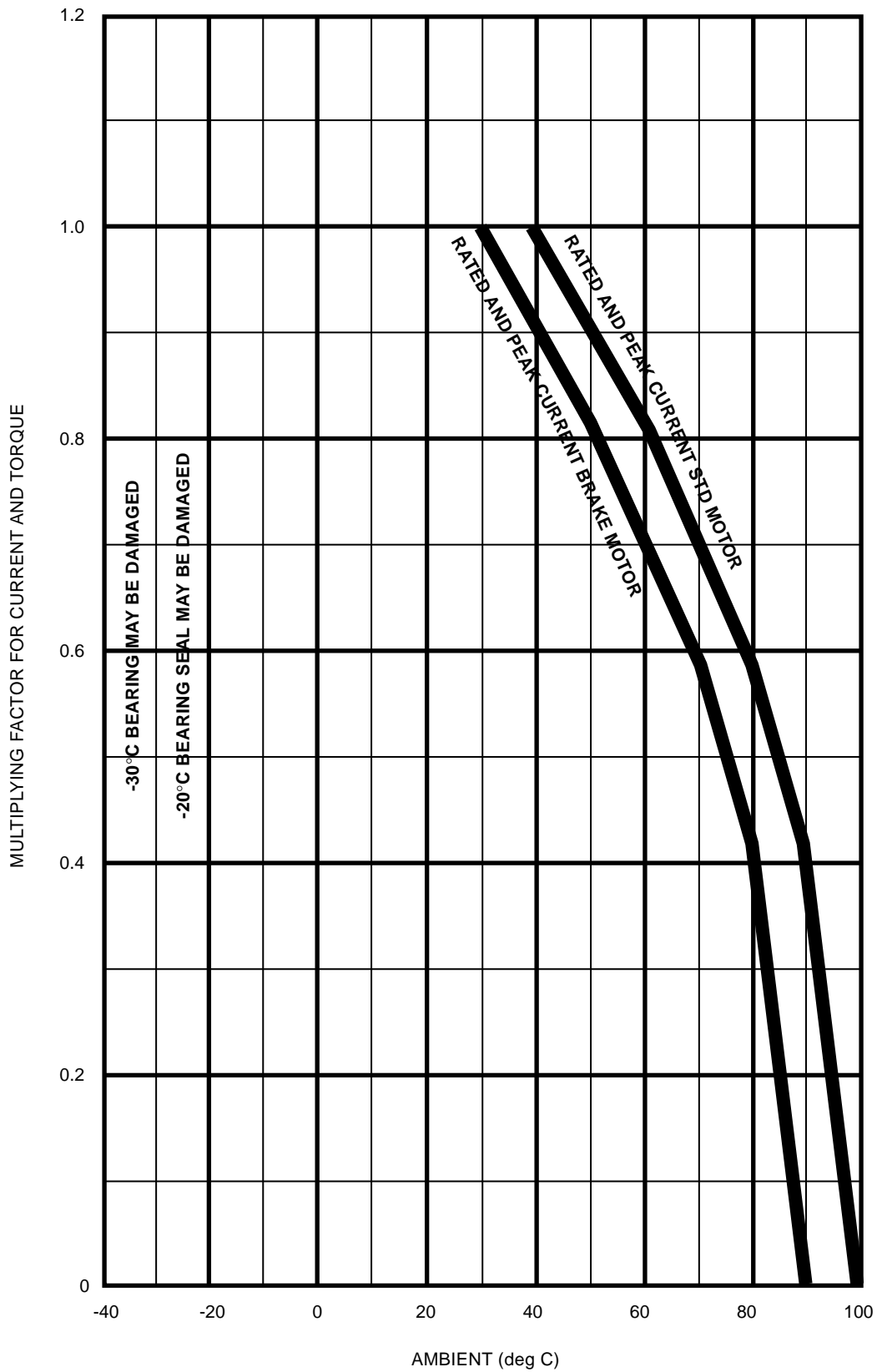

6

6

HDM58A6

HDM58C6

HDM58E6

HDM58G6

HDM58

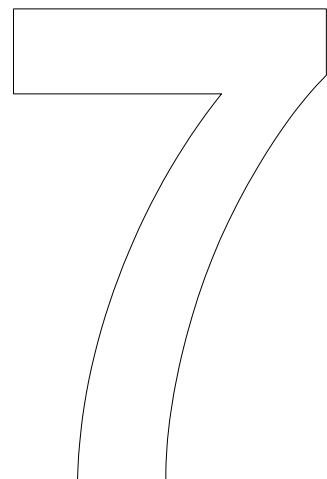

7.1 HDM58A6

HDM COMPACT SERVOMOTORS

Outline Drawing.

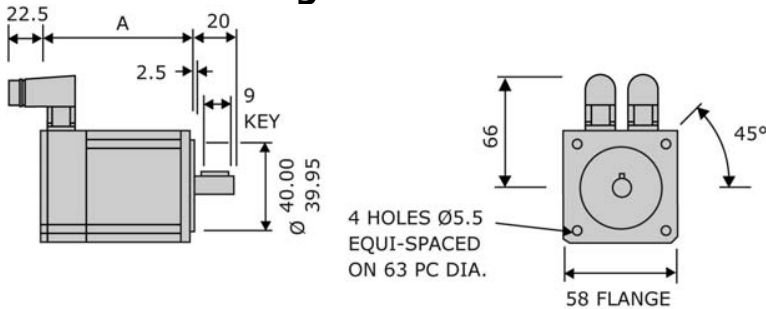

Frame	Dimension 'A'	
	without brake	with brake
HDM58A	88.5	123.5
HDM58C	106.0	141.0
HDM58E	123.5	158.5
HDM58G	141.0	176.0

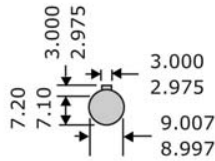

Technical Data.

Parameter	Units	HDM58	HDM58	HDM58
		A6-16S	A6-29S	A6-42S
Continuous Stall Torque 1	Nm	0.48	0.48	0.48
Continuous Stall Current 1	A	2.6	1.4	0.98
Rated Torque ¹	Nm	0.46	0.46	0.46
Rated Current ¹	A	2.4	1.35	0.96
Rated Speed	rpm	4500	4500	4500
Max. Speed (300V DC link)	rpm	8000	8000	7100
Max. Speed (560V DC link) ²	rpm	-----	8000	8000
Peak Stall Torque	Nm	1.15	1.15	1.15
Peak Current	A	10.9	6	4.1
Resistance Line-Line ³	Ω	3.7	12.2	25
Inductance Line-Line ⁴	mH	3.5	11.5	24
Voltage Gradient No Load	V	16	29	42
Max. Motor EMF Line - Line	Volts	128	230	340
Torque Constant Kt ^{3,5}	Nm/A	0.19	0.34	0.48
Number of Poles		6	6	6
THERMAL				
Insulation Class		F	F	F
Max. Ambient Temperature	°C	40	40	40
Thermal Time Constant	minutes	19	19	19
Thermal Resistance	°C/W	2.2	2.2	2.2
MECHANICAL				
Rotor Polar Moment of Inertia	kgcm ²	0.103	0.103	0.103
Static Friction Torque	Nm	0.02	0.02	0.02
Cogging Torque	Nm	0.03	0.03	0.03
Motor Weight	kg	0.81	0.81	0.81
Motor Weight with brake fitted	kg	TBA	TBA	TBA
Continuous Stall Torque (HR/HJ) ⁶	Nm	0.38	0.38	0.38

Notes

- ¹ - Motors are tested on an aluminium heatsink with dimensions 255x255x6mm and with a temperature rise ΔT of 100K on the windings. The maximum temperature of the windings is therefore 140°C.
- ² - Where no motor speed is specified, optimal performance may not be achieved on 560V DC link.
- ³ - At 25°C.
- ⁴ - Inductance values are based on nominal current.
- ⁵ - At rated values Torque = $K_t \times \text{rms current}$.
- ⁶ - Continuous Stall Torque (HR/HJ)⁶ is for use in comparisons with SEM's HR and HJ servomotors only.

DD0700 ISSUE 1

PROVISIONAL
HDM58A6
ON 150V
WITHOUT SHAFT SEAL

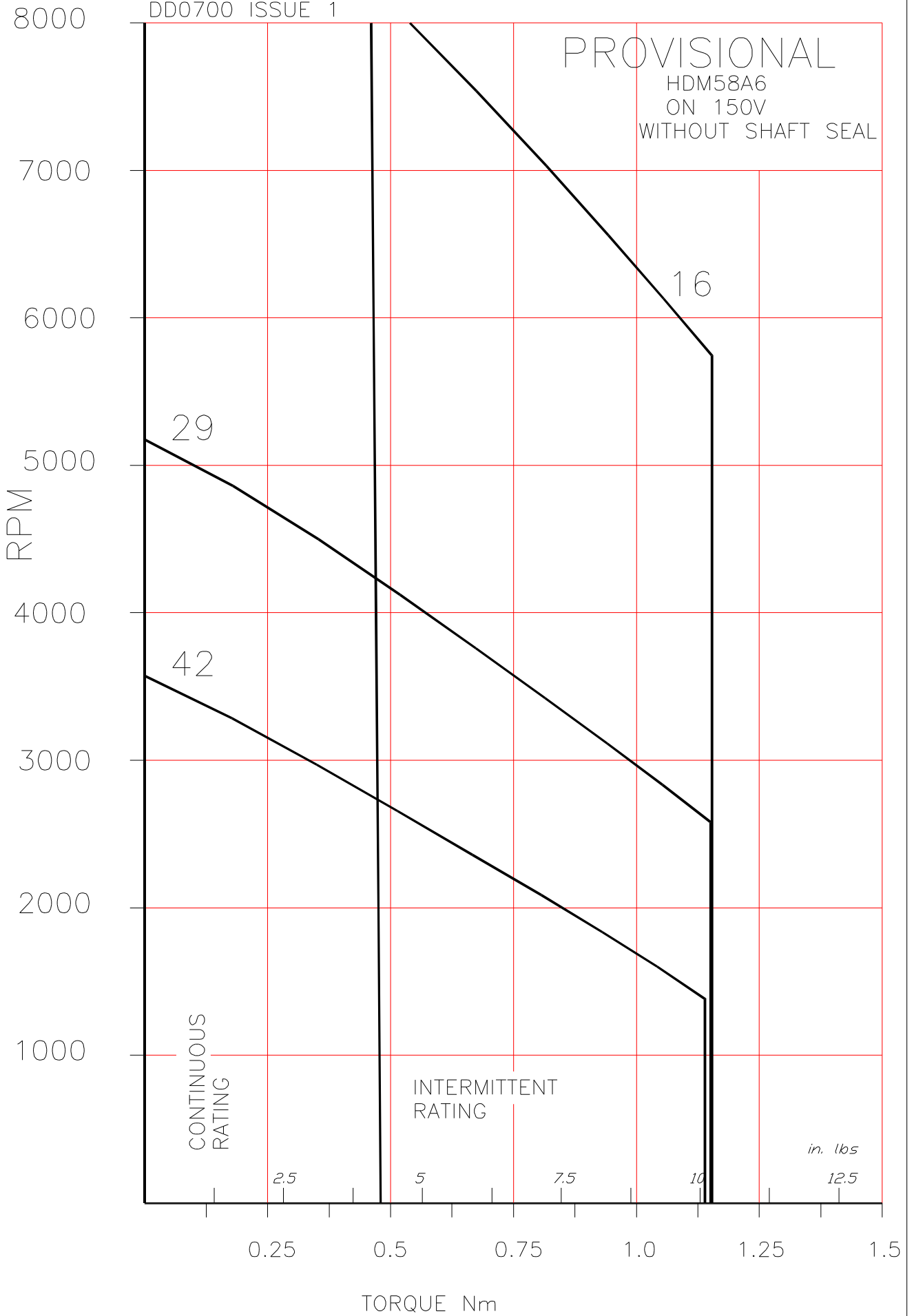

DD0708 ISSUE 1

PROVISIONAL

HDM58A6
ON 300V
WITHOUT SHAFT SEAL

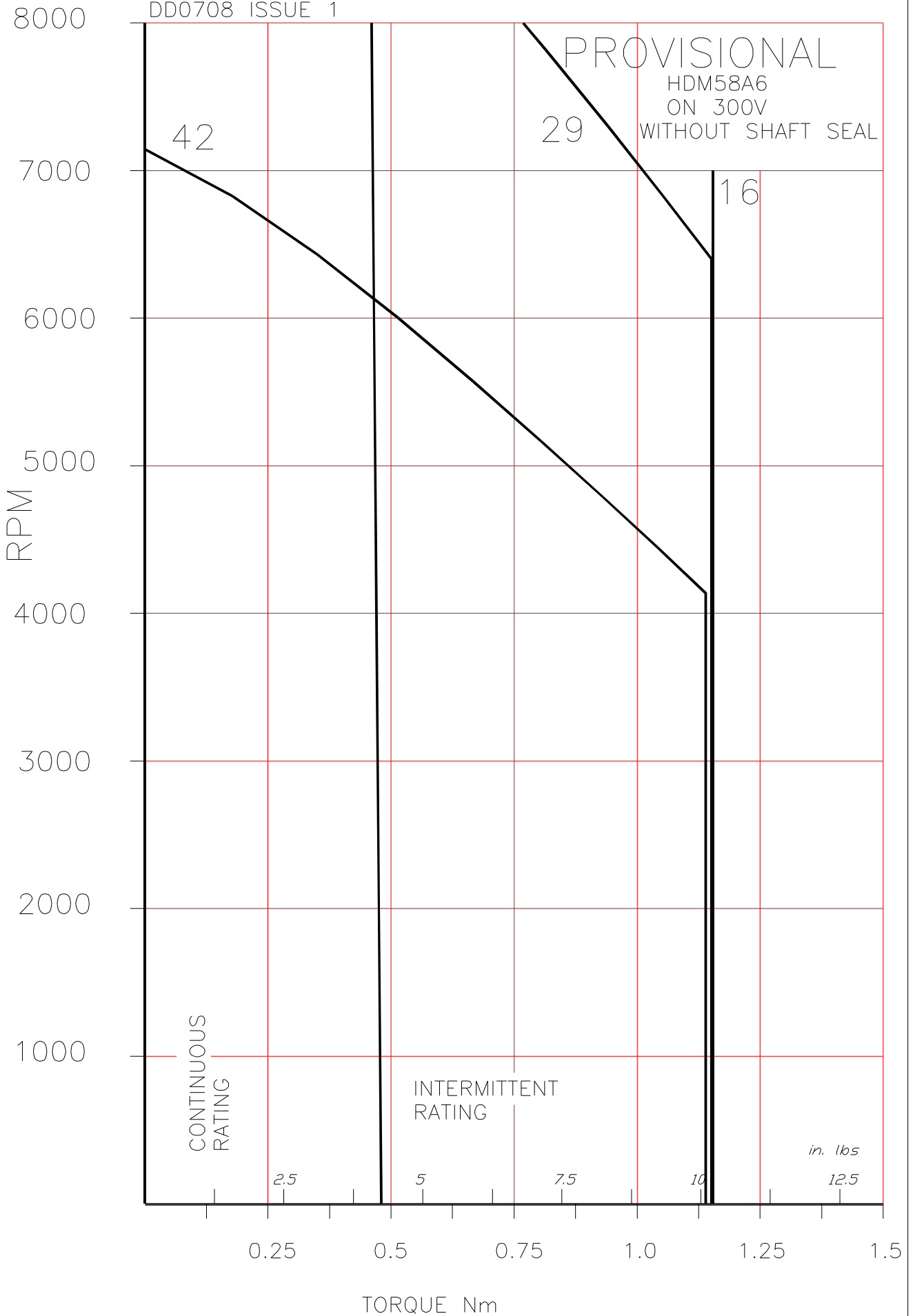

DD0712 ISSUE 1

PROVISIONAL

HDM58A6
ON 560V
WITHOUT SHAFT SEAL

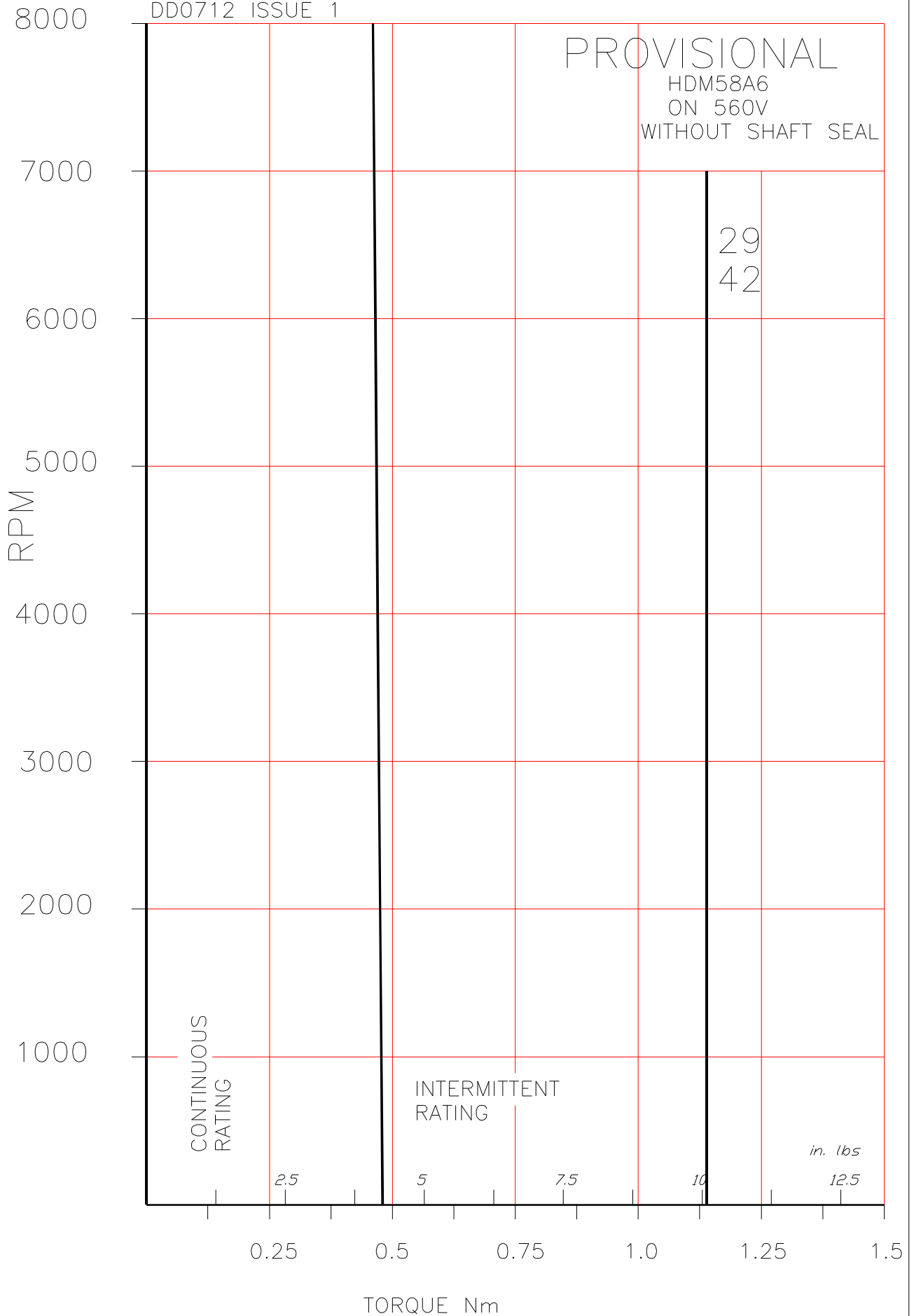

29
42

CONTINUOUS
RATING

INTERMITTENT
RATING

in. lbs

2.5

5

7.5

10

12.5

0.25

0.5

0.75

1.0

1.25

1.5

TORQUE Nm

DD0716 ISSUE 1

PROVISIONAL

HDM58A6
ON 650V
WITHOUT SHAFT SEAL

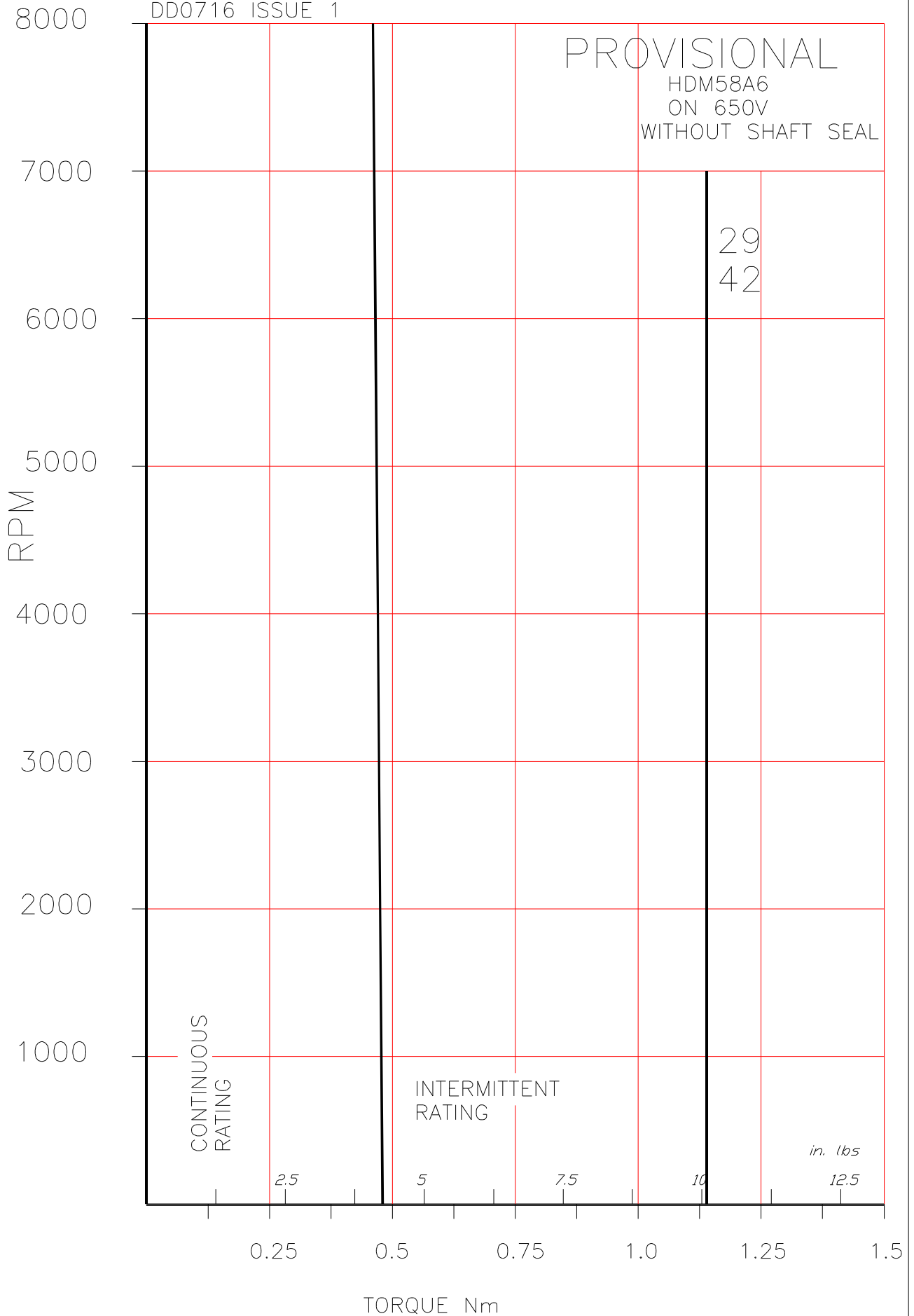

7.2 HDM58C6

HDM COMPACT SERVOMOTORS

Outline Drawing.

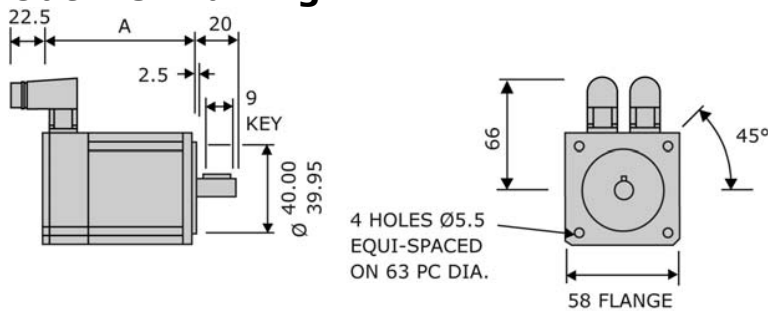

Frame	Dimension 'A'	
	without brake	with brake
HDM58A	88.5	123.5
HDM58C	106.0	141.0
HDM58E	123.5	158.5
HDM58G	141.0	176.0

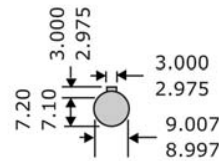

Technical Data.

Parameter	Units	HDM58 C6-21S	HDM58 C6-47S	HDM58 C6-73S
Continuous Stall Torque 1	Nm	0.85	0.85	0.85
Continuous Stall Current 1	A	3.5	1.5	1
Rated Torque ¹	Nm	0.8	0.8	0.8
Rated Current ¹	A	3.2	1.48	0.95
Rated Speed	rpm	4500	4500	4500
Max. Speed (300V DC link)	rpm	8000	6400	4100
Max. Speed (560V DC link) ²	rpm	-----	8000	7700
Peak Stall Torque	Nm	2.3	2.3	2.3
Peak Current	A	16	7.4	4.8
Resistance Line-Line ³	Ω	2.5	12.2	29
Inductance Line-Line ⁴	mH	2.6	13	31
Voltage Gradient No Load	V	21	47	73
Max. Motor EMF Line - Line	Volts	170	380	580
Torque Constant Kt ^{3,5}	Nm/A	0.25	0.54	0.84
Number of Poles		6	6	6
THERMAL				
Insulation Class		F	F	F
Max. Ambient Temperature	°C	40	40	40
Thermal Time Constant	minutes	30	30	30
Thermal Resistance	°C/W	1.8	1.8	1.8
MECHANICAL				
Rotor Polar Moment of Inertia	kgcm ²	0.15	0.15	0.15
Static Friction Torque	Nm	0.02	0.02	0.02
Cogging Torque	Nm	0.04	0.04	0.04
Motor Weight	kg	1.1	1.1	1.1
Motor Weight with brake fitted	kg	TBA	TBA	TBA
Continuous Stall Torque (HR/HJ) ⁶	Nm	0.68	0.68	0.68

Notes

- Motors are tested on an aluminium heatsink with dimensions 255x255x6mm and with a temperature rise ΔT of 100K on the windings. The maximum temperature of the windings is therefore 140°C.
- Where no motor speed is specified, optimal performance may not be achieved on 560V DC link.
- At 25°C.
- Inductance values are based on nominal current.
- At rated values Torque = $K_t \times \text{rms current}$.
- Continuous Stall Torque (HR/HJ)⁶ is for use in comparisons with SEM's HR and HJ servomotors only.

DD0701 ISSUE 1

PROVISIONAL
HDM58C6
ON 150V
WITHOUT SHAFT SEAL

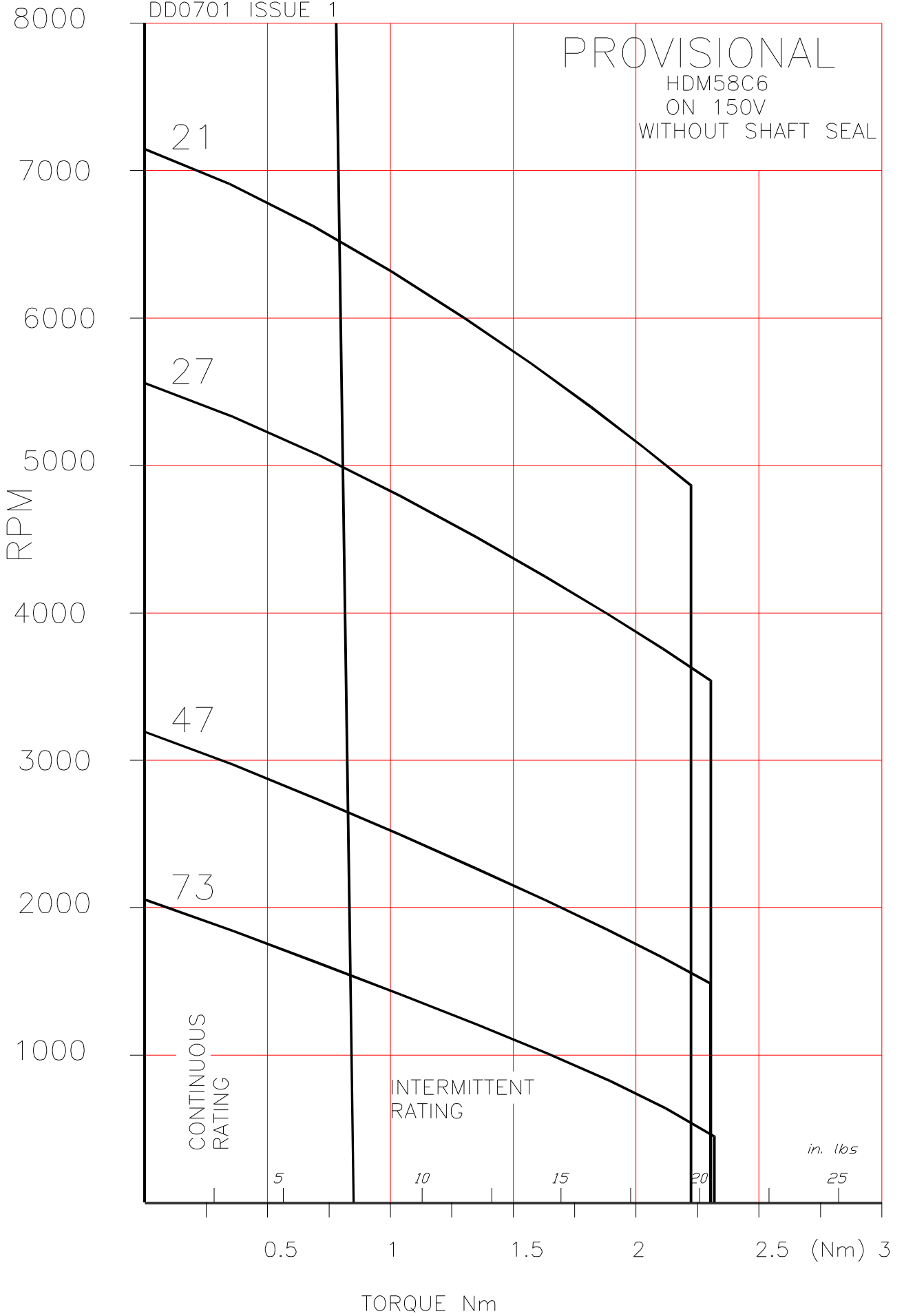

PROVISIONAL
HDM58C6
ON 300V
WITHOUT SHAFT SEAL

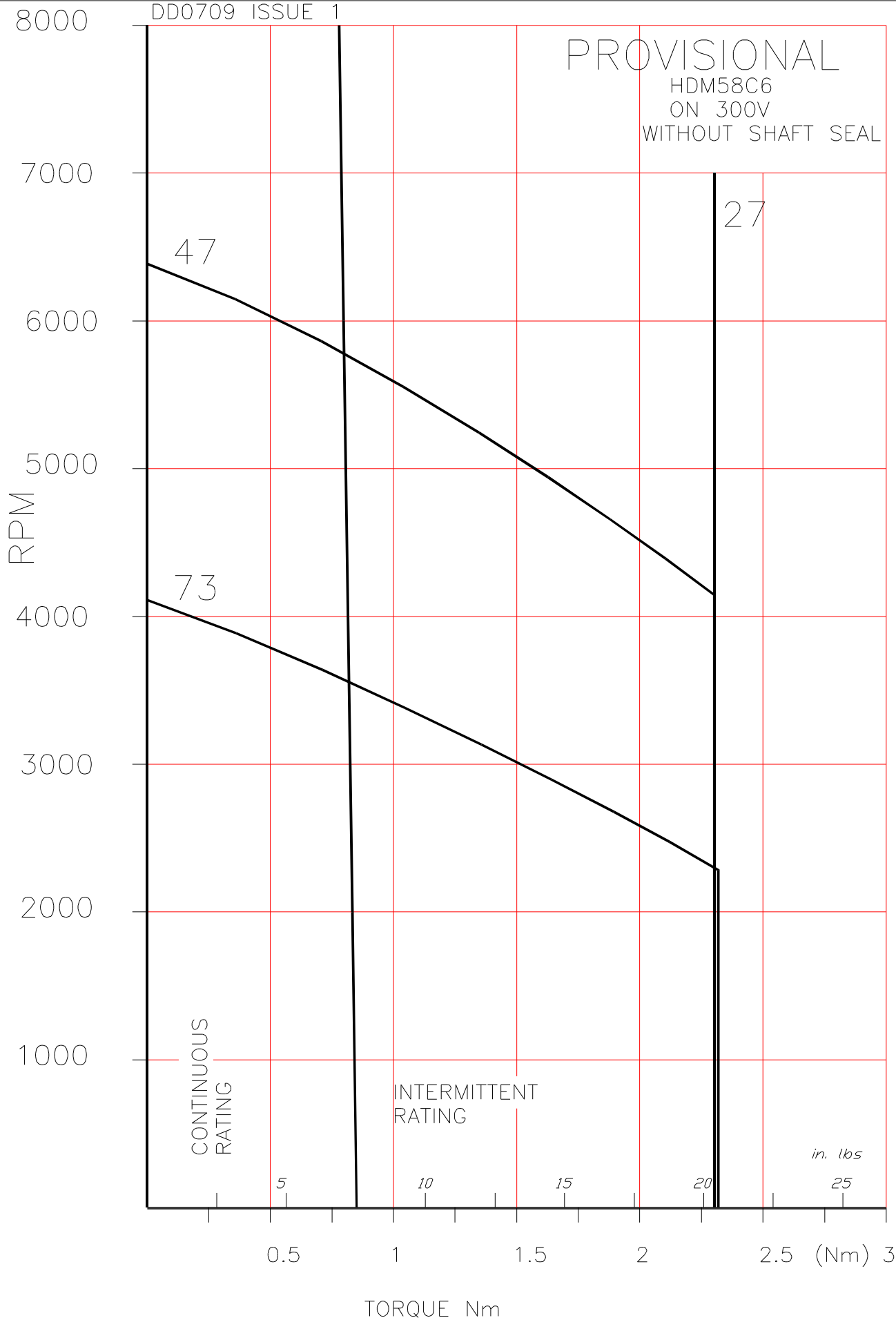

CONTINUOUS
RATING

INTERMITTENT
RATING

in. lbs

5 10 15 20 25 (Nm) 3

TORQUE Nm

DD0713 ISSUE 1

PROVISIONAL

HDM58C6
ON 560V
WITHOUT SHAFT SEAL

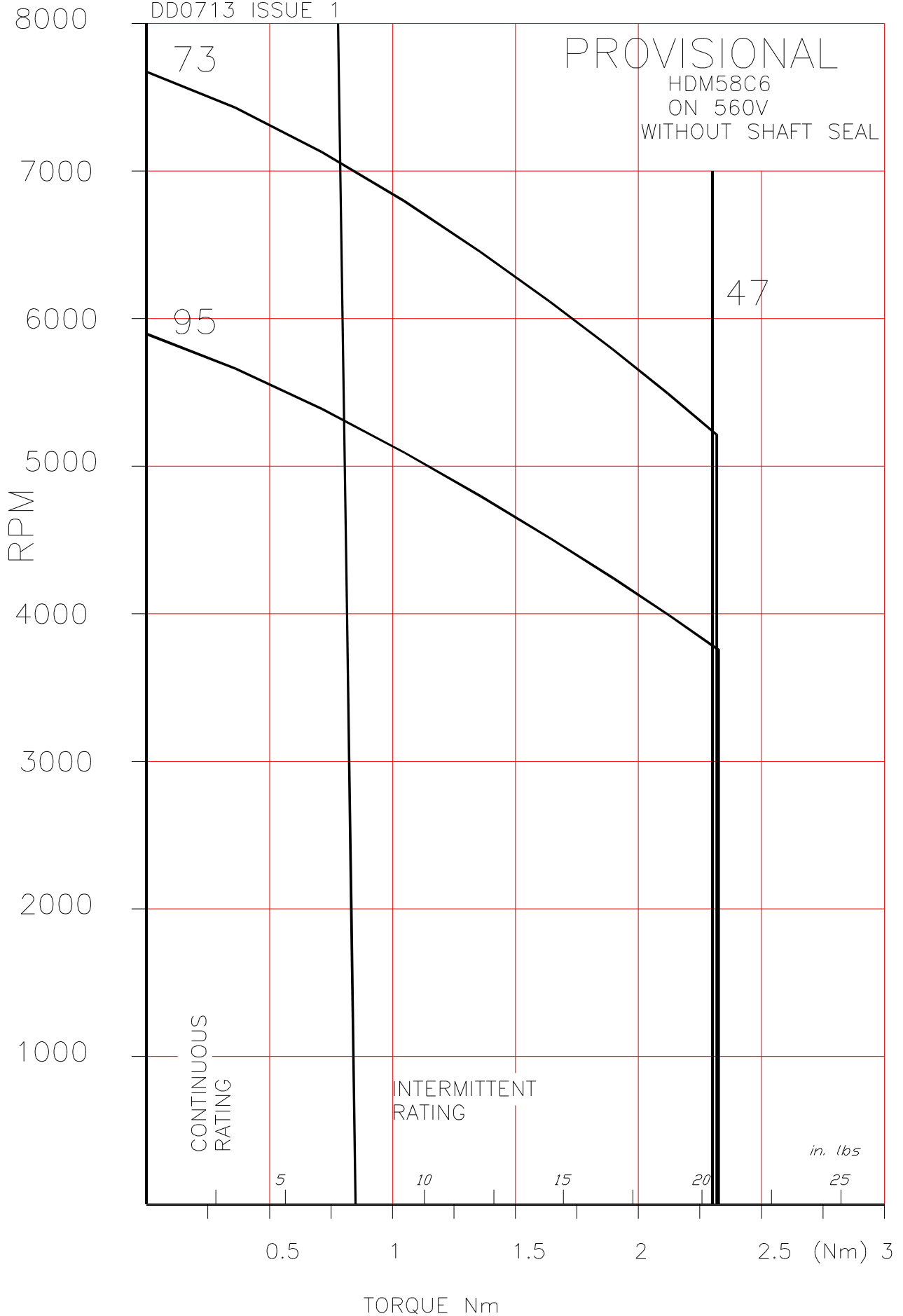

CONTINUOUS
RATING

INTERMITTENT
RATING

in. lbs

5

10

15

20

25

0.5

1

1.5

2

2.5

(Nm) 3

TORQUE Nm

DD0717 ISSUE 1

PROVISIONAL

HDM58C6
ON 650V
WITHOUT SHAFT SEAL

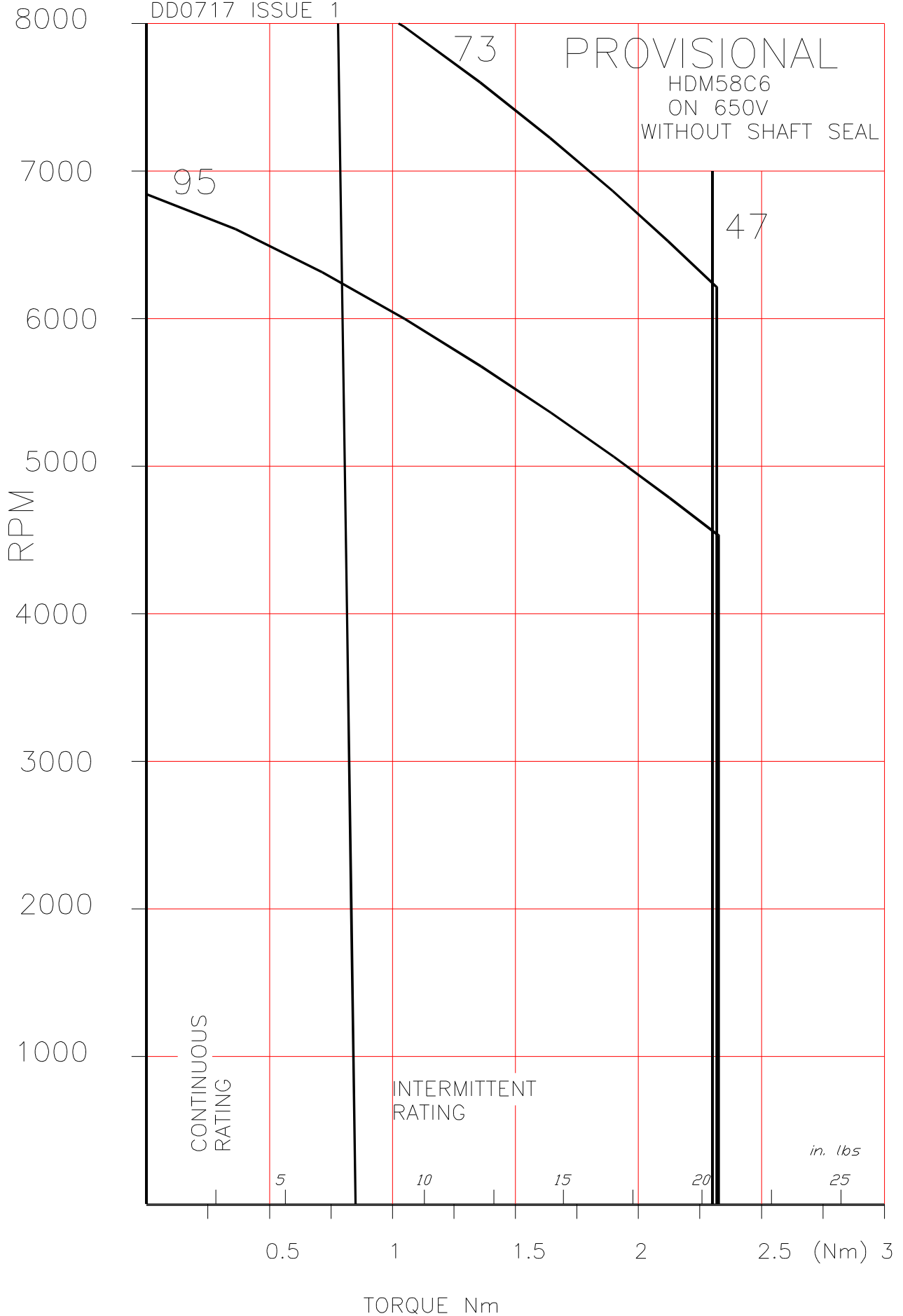

CONTINUOUS
RATING

INTERMITTENT
RATING

in. lbs

5 10 15 20 25 (Nm) 3

TORQUE Nm

7.3 HDM58E6

HDM COMPACT SERVOMOTORS

Outline Drawing.

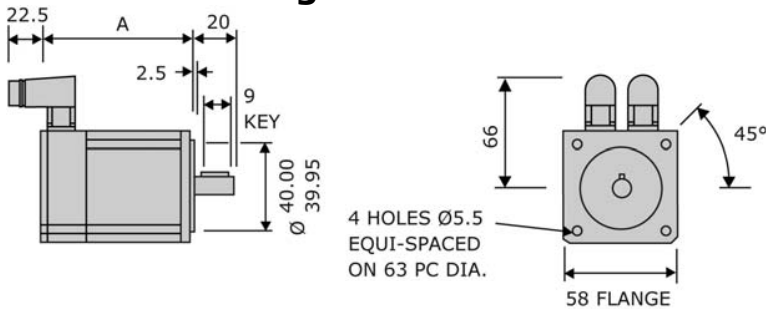

Frame	Dimension 'A'	
	without brake	with brake
HDM58A	88.5	123.5
HDM58C	106.0	141.0
HDM58E	123.5	158.5
HDM58G	141.0	176.0

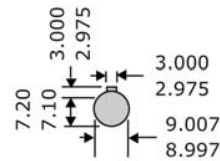

SHAFT END DETAIL

Technical Data.

Parameter	Units	HDM58 E6-40S	HDM58 E6-70S	HDM58 E6-100S
Continuous Stall Torque 1	Nm	1.15	1.15	1.15
Continuous Stall Current 1	A	2.5	1.4	0.98
Rated Torque ¹	Nm	1.1	1.1	1.1
Rated Current ¹	A	2.3	1.36	0.94
Rated Speed	rpm	4500	4500	4500
Max. Speed (300V DC link)	rpm	7500	4300	3000
Max. Speed (560V DC link) ²	rpm	8000	8000	5600
Peak Stall Torque	Nm	3.5	3.5	3.5
Peak Current	A	13.1	7.5	5.2
Resistance Line-Line ³	Ω	5.2	16	33
Inductance Line-Line ⁴	mH	6.1	18.5	38
Voltage Gradient No Load	V	40	70	100
Max. Motor EMF Line - Line	Volts	320	560	700
Torque Constant Kt ^{3,5}	Nm/A	0.48	0.81	1.17
Number of Poles		6	6	6
THERMAL				
Insulation Class		F	F	F
Max. Ambient Temperature	°C	40	40	40
Thermal Time Constant	minutes	30	30	30
Thermal Resistance	°C/W	1.6	1.6	1.6
MECHANICAL				
Rotor Polar Moment of Inertia	kgcm ²	0.2	0.2	0.2
Static Friction Torque	Nm	0.02	0.02	0.02
Cogging Torque	Nm	0.045	0.045	0.045
Motor Weight	kg	1.4	1.4	1.4
Motor Weight with brake fitted	kg	TBA	TBA	TBA
Continuous Stall Torque (HR/HJ) ⁶	Nm	1	1	1

Notes

- Motors are tested on an aluminium heatsink with dimensions 255x255x6mm and with a temperature rise ΔT of 100K on the windings. The maximum temperature of the windings is therefore 140°C.
- Where no motor speed is specified, optimal performance may not be achieved on 560V DC link.
- At 25°C.
- Inductance values are based on nominal current.
- At rated values Torque = $K_t \times \text{rms current}$.
- Continuous Stall Torque (HR/HJ)⁶ is for use in comparisons with SEM's HR and HJ servomotors only.

PROVISIONAL
HDM58E6
ON 150V
WITHOUT SHAFT SEAL

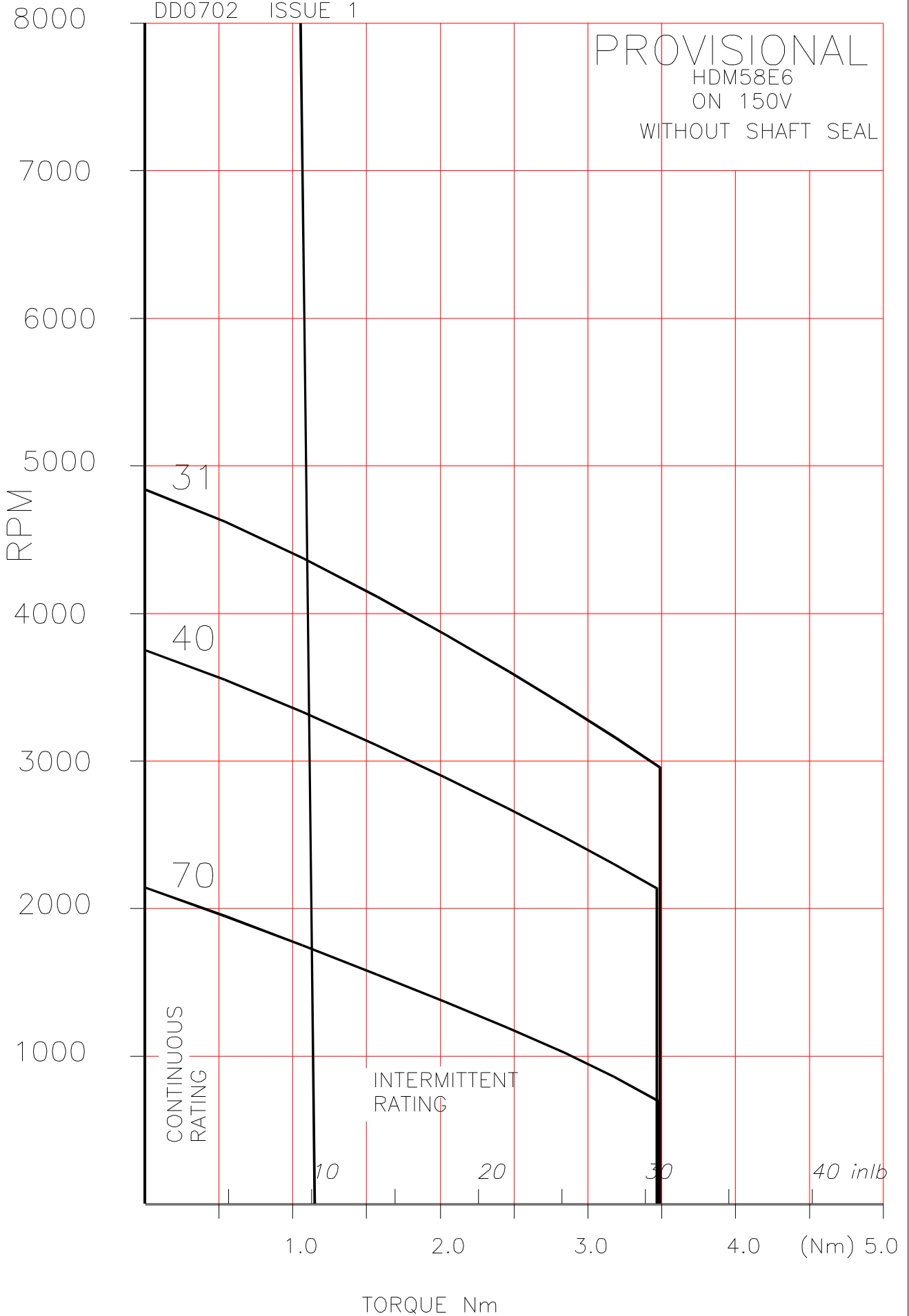

DD0710 ISSUE 1

PROVISIONAL
HDM58E6
ON 300V
WITHOUT SHAFT SEAL

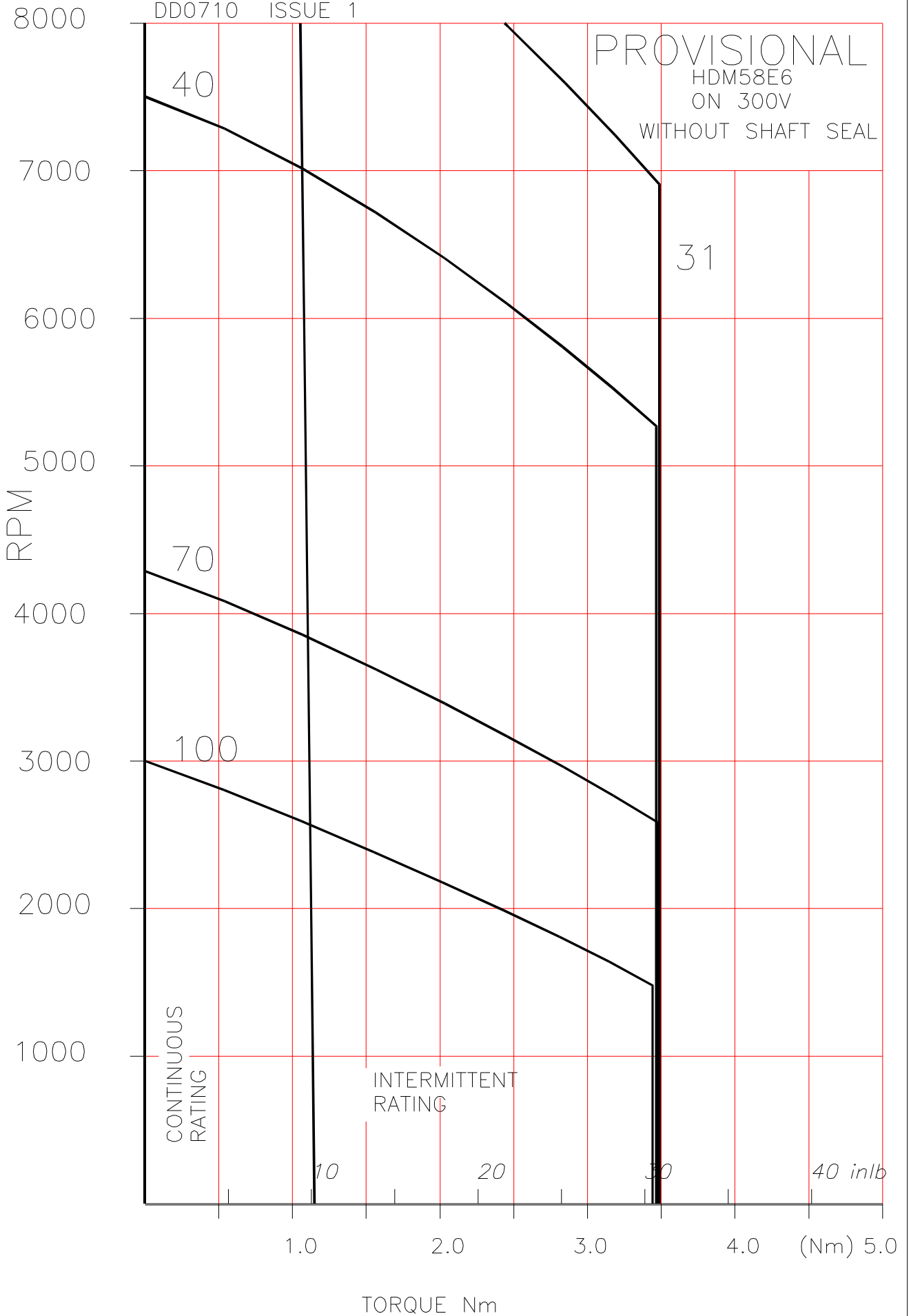

DD0714 ISSUE 1

PROVISIONAL
HDM58E6
ON 560V
WITHOUT SHAFT SEAL

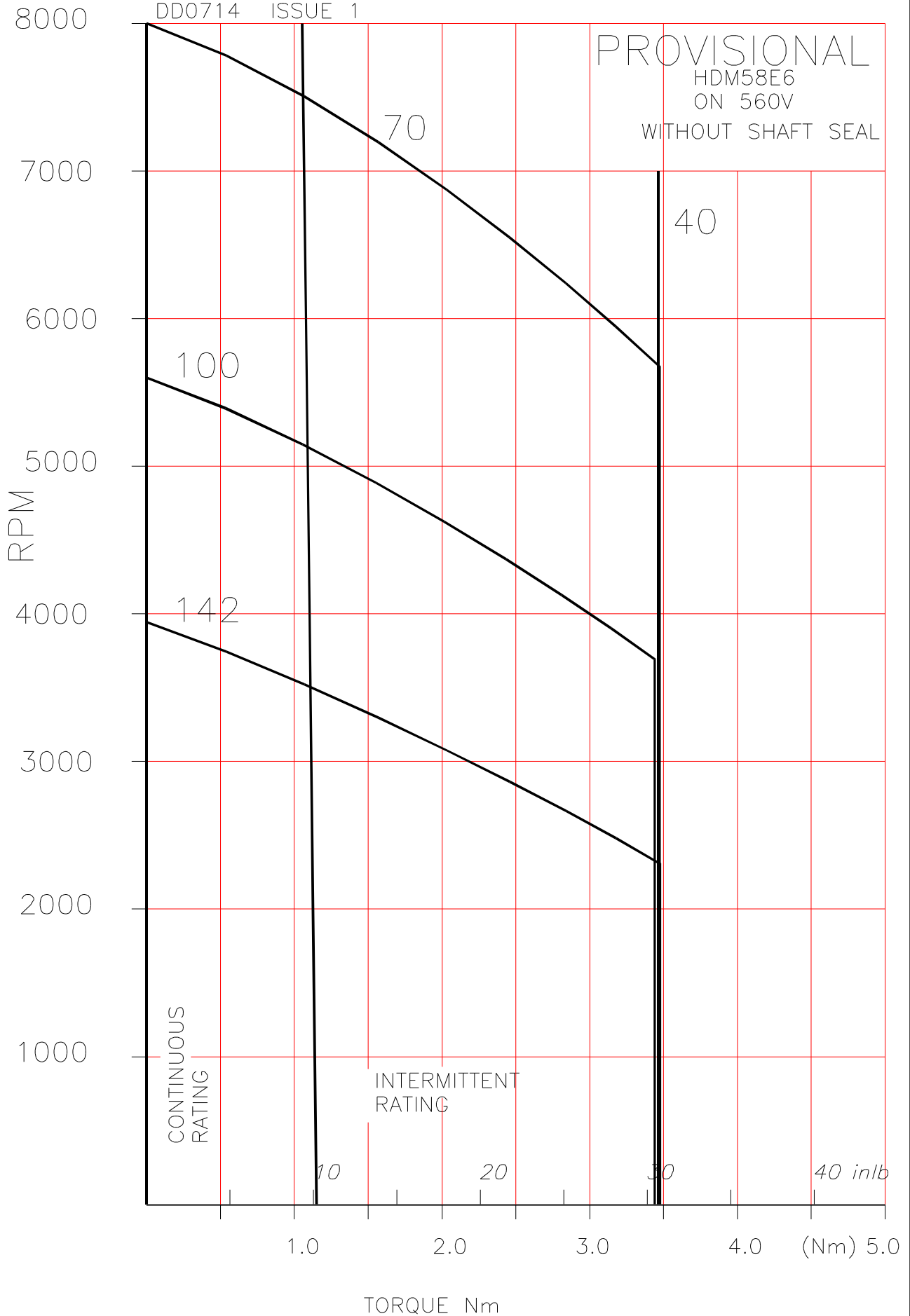

DD0718 ISSUE 1

70 PROVISIONAL
HDM58E6
ON 650V
WITHOUT SHAFT SEAL

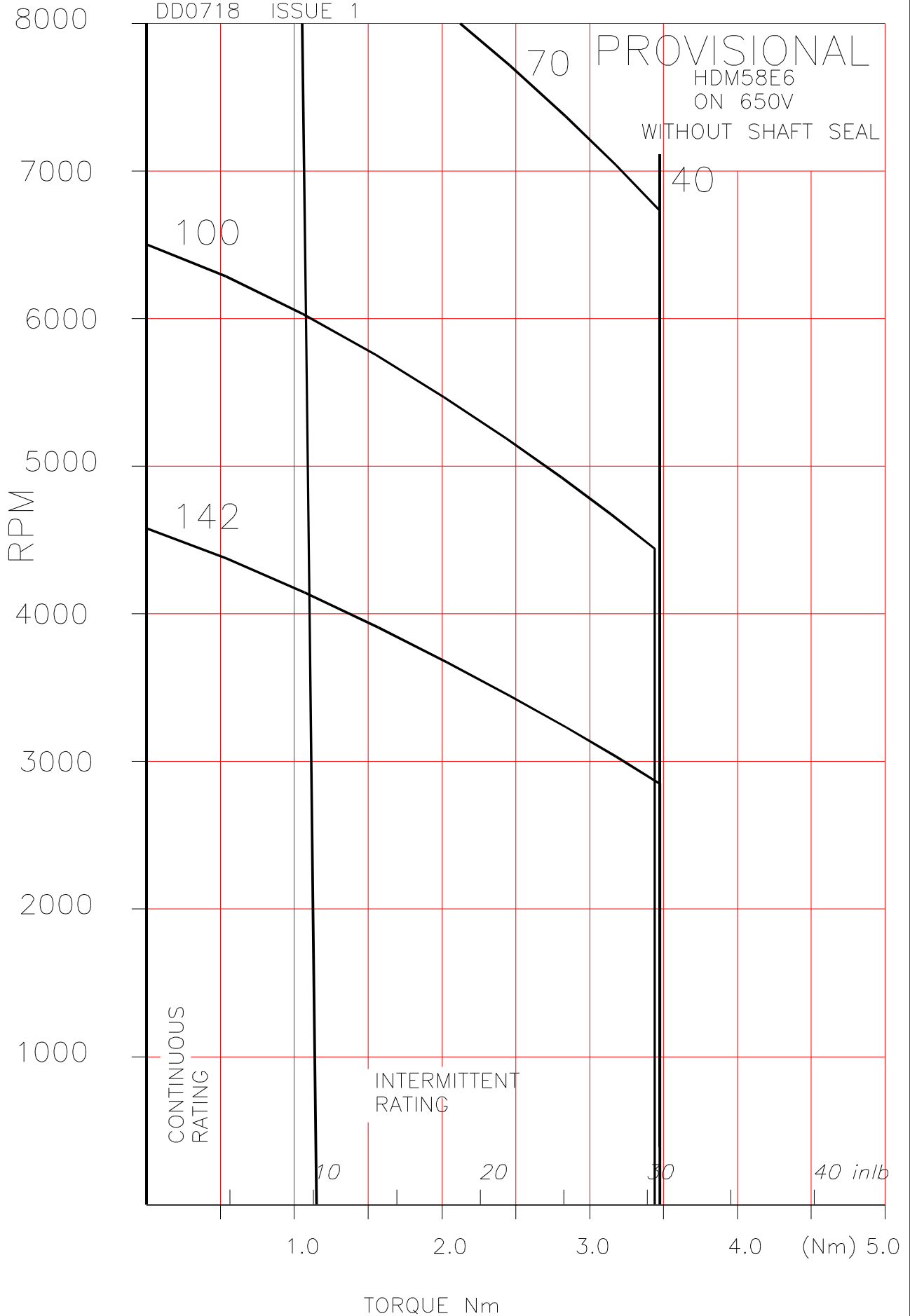

7.4 HDM58G6

HDM COMPACT SERVOMOTORS

Outline Drawing.

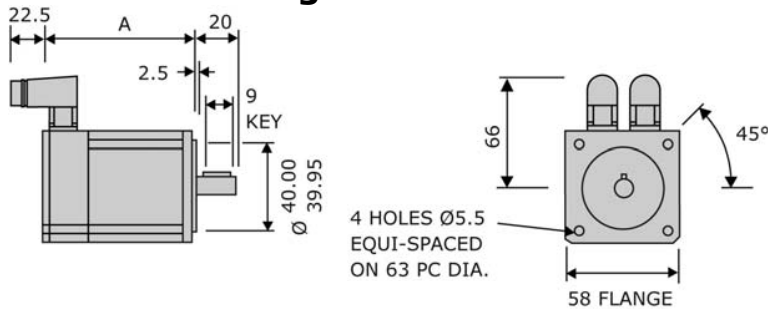

Frame	Dimension 'A'	
	without brake	with brake
HDM58A	88.5	123.5
HDM58C	106.0	141.0
HDM58E	123.5	158.5
HDM58G	141.0	176.0

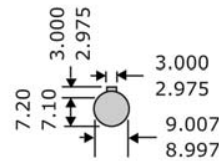

SHAFT END DETAIL

Technical Data.

Parameter	Units	HDM58 G6-53S	HDM58 G6-82S	HDM58 G6-118S
Continuous Stall Torque 1	Nm	1.5	1.5	1.5
Continuous Stall Current 1	A	2.4	1.6	1.09
Rated Torque ¹	Nm	1.3	1.3	1.3
Rated Current ¹	A	2.1	1.35	0.94
Rated Speed	rpm	4500	4500	4500
Max. Speed (300V DC link)	rpm	5700	3700	2500
Max. Speed (560V DC link) ²	rpm	8000	6800	4700
Peak Stall Torque	Nm	4.6	4.6	4.6
Peak Current	A	13.1	8.5	5.9
Resistance Line-Line ³	Ω	6.6	16	33
Inductance Line-Line ⁴	mH	8	19	39.5
Voltage Gradient No Load	V	53	82	118
Max. Motor EMF Line - Line	Volts	420	660	700
Torque Constant Kt ^{3,5}	Nm/A	0.63	0.96	1.38
Number of Poles		6	6	6
THERMAL				
Insulation Class		F	F	F
Max. Ambient Temperature	°C	40	40	40
Thermal Time Constant	minutes	30	30	30
Thermal Resistance	°C/W	1.34	1.34	1.34
MECHANICAL				
Rotor Polar Moment of Inertia	kgcm ²	0.25	0.25	0.25
Static Friction Torque	Nm	0.02	0.02	0.02
Cogging Torque	Nm	0.05	0.05	0.05
Motor Weight	kg	1.7	1.7	1.7
Motor Weight with brake fitted	kg	TBA	TBA	TBA
Continuous Stall Torque (HR/HJ) ⁶	Nm	1.3	1.3	1.3

Notes

- Motors are tested on an aluminium heatsink with dimensions 255x255x6mm and with a temperature rise ΔT of 100K on the windings. The maximum temperature of the windings is therefore 140°C.
- Where no motor speed is specified, optimal performance may not be achieved on 560V DC link.
- At 25°C.
- Inductance values are based on nominal current.
- At rated values Torque = $K_t \times \text{rms current}$.
- Continuous Stall Torque (HR/HJ)⁶ is for use in comparisons with SEM's HR and HJ servomotors only.

DD0703 ISSUE 1

PROVISIONAL
HDM58G6
ON 150V
WITHOUT SHAFT SEAL

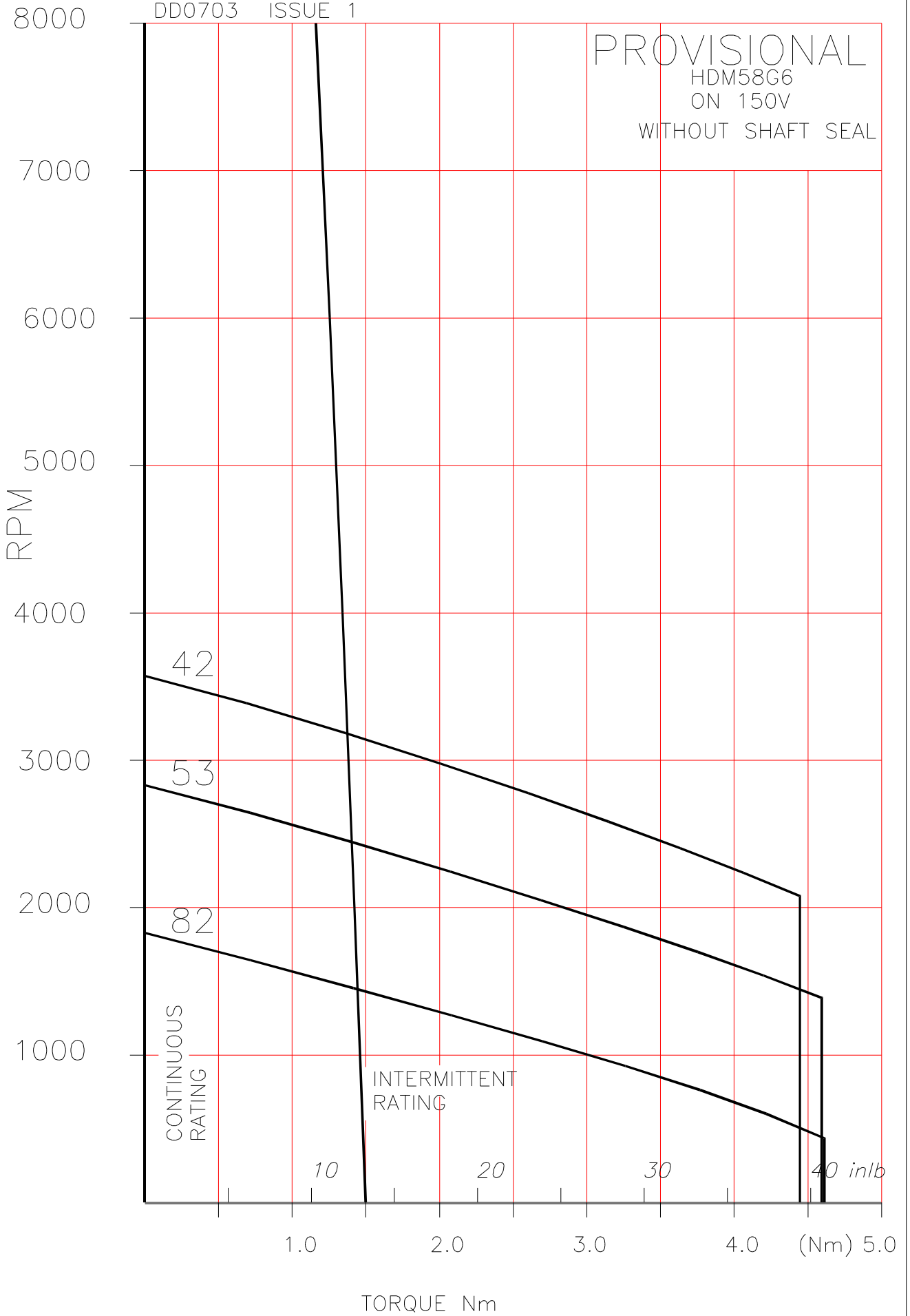

DD0711 ISSUE 1

PROVISIONAL
HDM58G6
ON 300V
WITHOUT SHAFT SEAL

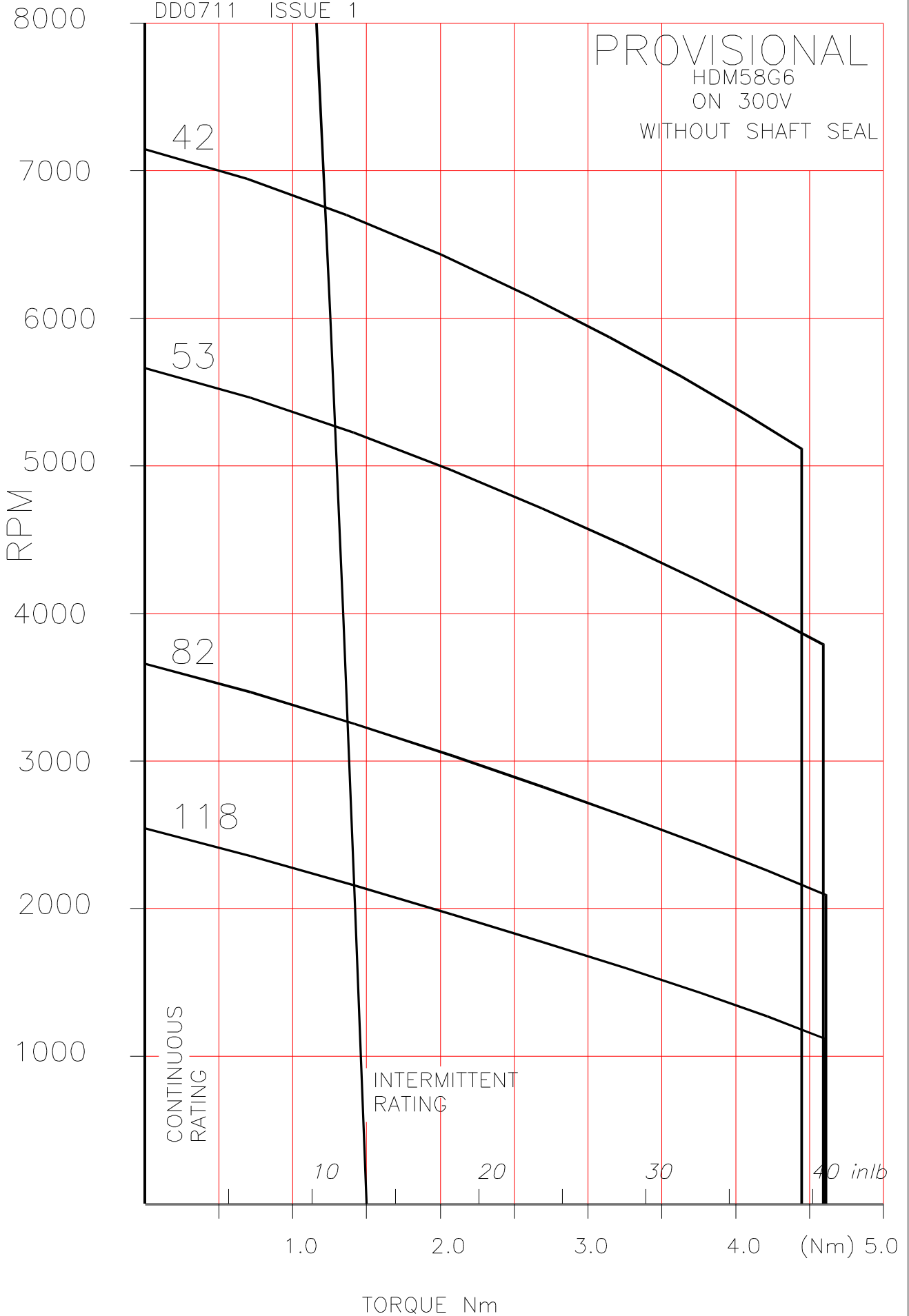

DD0715 ISSUE 1

PROVISIONAL
HDM58G6
ON 560V
WITHOUT SHAFT SEAL

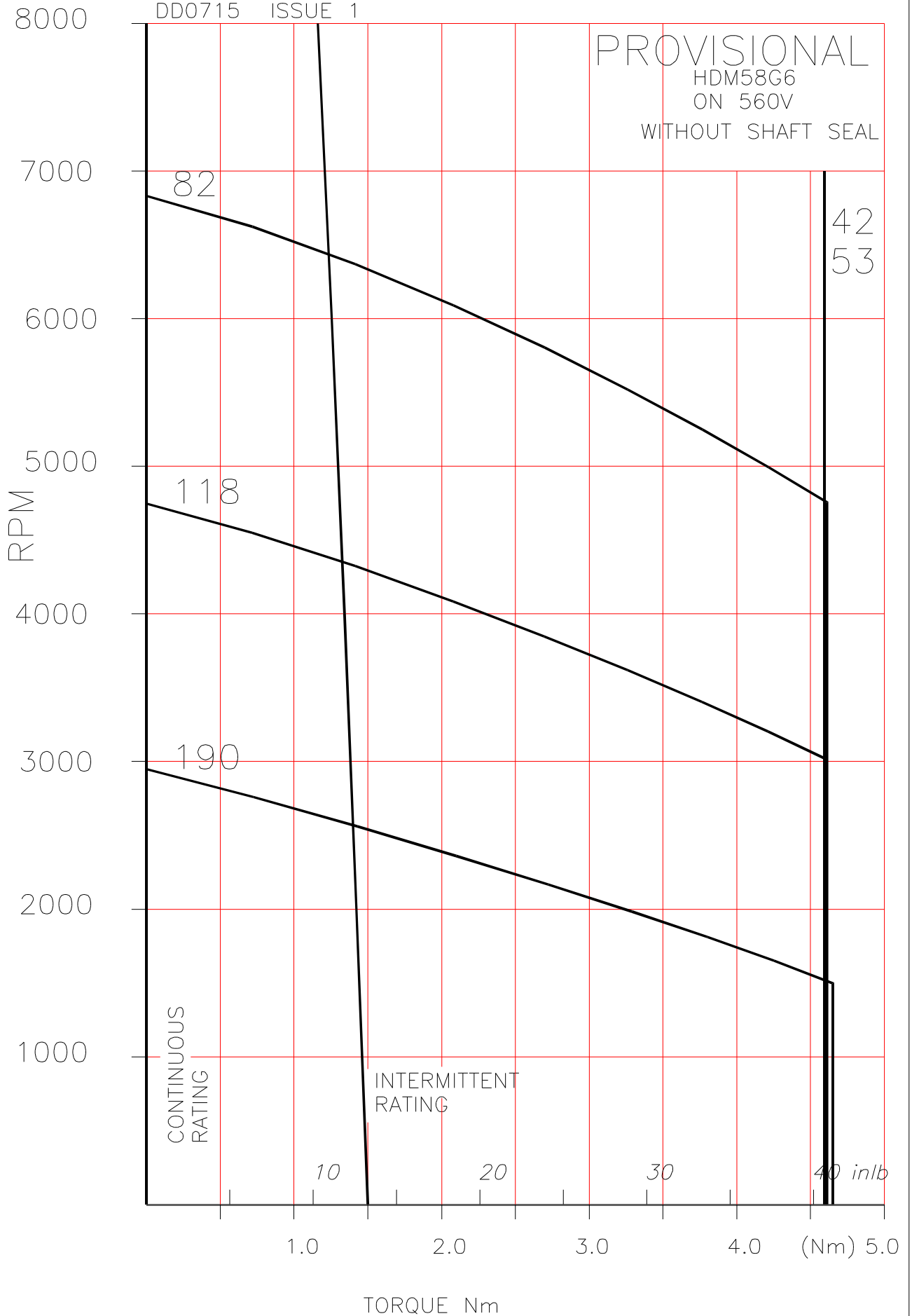

PROVISIONAL
HDM58G6
ON 650V
WITHOUT SHAFT SEAL

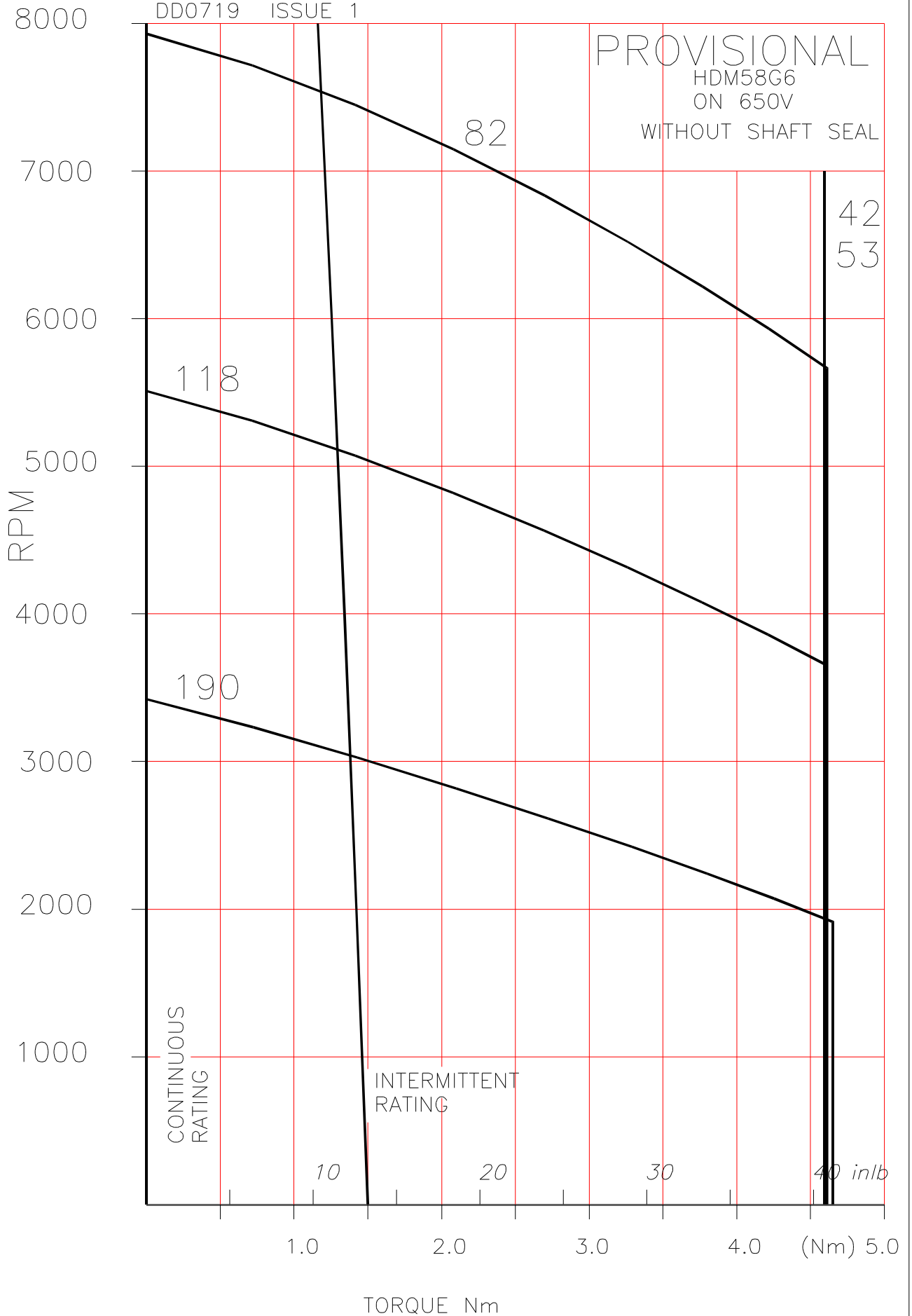

HDM58 PERMITTED RADIAL SHAFT LOADINGS

(If axial loads are to be applied, the equivalent radial loading must be calculated as described on next page)

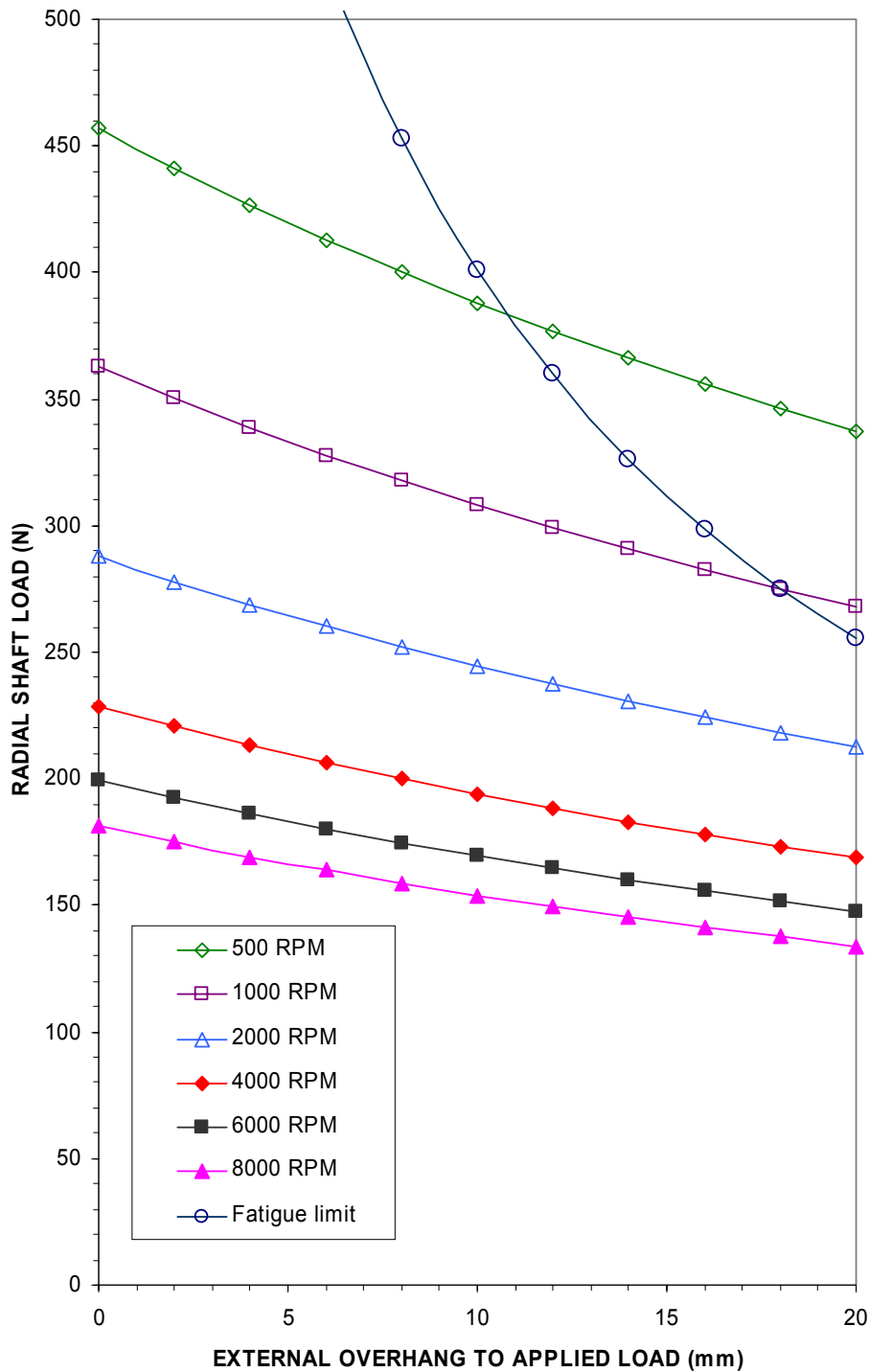

Shaft Loading Information for SEM Standard Servomotors

General notes:-

- 1 All loadings are based upon An L10 bearing life expectancy of 30,000 hours.
- 2 Separate graphs are usually supplied to indicate maximum axial loads which are applicable. However, for motors with locked drive end bearings, a graph is used to illustrate the maximum allowed radial shaft loadings together with a simplified calculation to provide a compensated figure for when radial and axial loadings are to be applied in combination.
- 3 It may occur, in certain circumstances, that loading outside the scope of the published information is deemed necessary. In these cases it is desirable that SEM Ltd should be consulted and all relevant information made available, in order that due consideration can be given to finding a satisfactory solution.
- 4 Should motors be required to operate under abnormal conditions, such as excessive vibration or shock, this should also be referred to SEM Ltd as noted above.

HDM58 COMBINATION OF AXIAL AND RADIAL LOADING

Calculated combined load must NOT EXCEED the Radial Shaft loadings as per Radial Loading Chart

Equivalent radial load (P_r) = $0.56F_r + Y_{fa}$

Where F_r = Applied radial load

or = F_r (Whichever is the larger)

F_a = Applied axial load (232N Max)

Y_{fa} = Value taken from chart

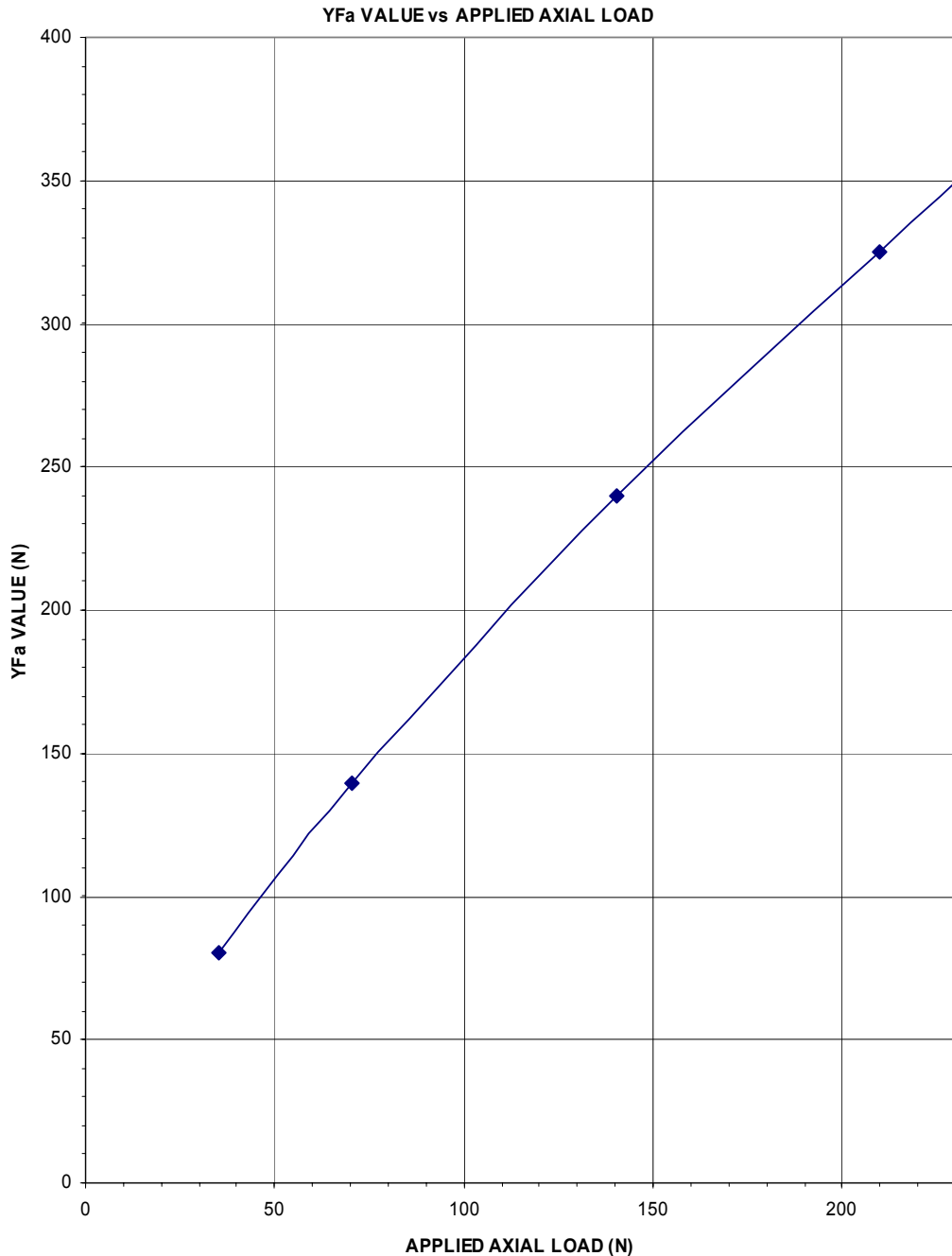

Shaft Loading Information for SEM Standard Servomotors

General notes:-

1 All loadings are based upon An L10 bearing life expectancy of 30,000 hours.

2 Separate graphs are usually supplied to indicate maximum axial loads which are applicable. However, for motors with locked drive end bearings, a graph is used to illustrate the maximum allowed radial shaft loadings together with a simplified calculation to provide a compensated figure for when radial and axial loadings are to be applied in combination.

3 It may occur, in certain circumstances, that loading outside the scope of the published information is deemed necessary. In these cases it is desirable that SEM Ltd should be consulted and all relevant information made available, in order that due consideration can be given to finding a satisfactory solution.

4 Should motors be required to operate under abnormal conditions, such as excessive vibration or shock, this should also be referred to SEM Ltd as noted above.

FIRST ANGLE PROJECTION

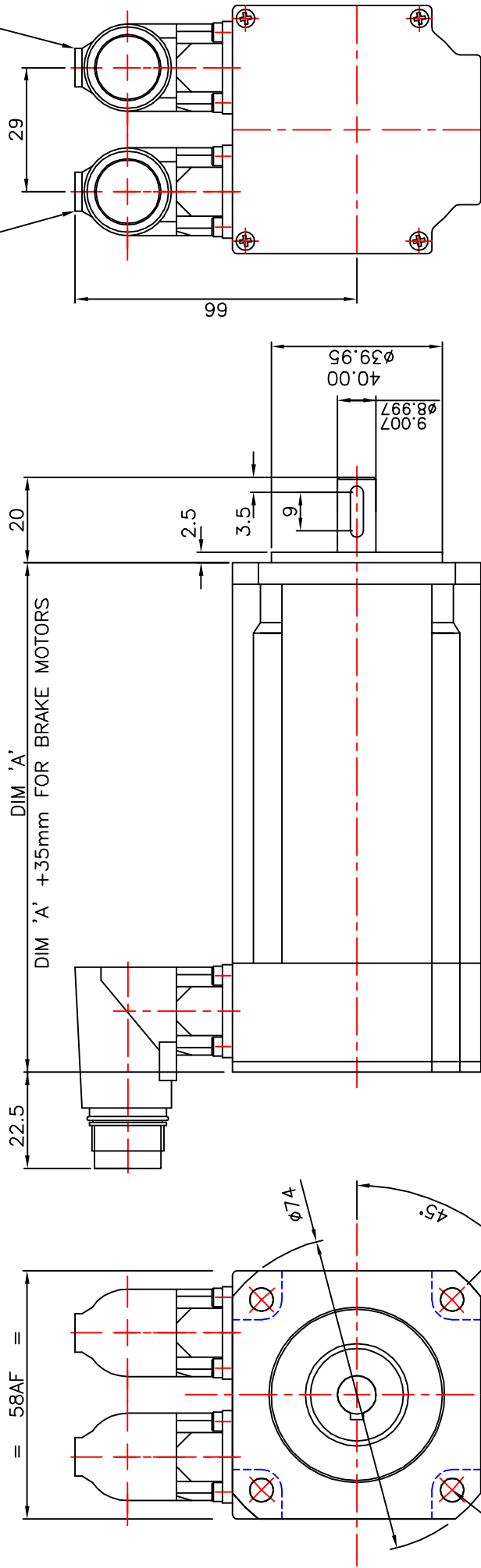

VIEW ON DRIVE END

4 HOLES $\phi 5.5$ EQUISPACED ON 63PCD

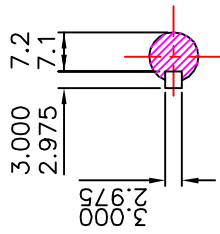

SHAFT DETAIL AT DE

FRAME	DIM 'A'
HDM58A	88.5
HDM58C	106.0
HDM58E	123.5
HDM58G	141.0

FOR CONNECTORS FACING DE SEE 664-7-06522

2 NOW SHOWN WITH WITH CAST BODY/DE (PRE-ISSUE CHANGE)		TITLE : OUTLINE HDM58 STD MET WITH M17 CONNS FACING NDE		DRAWING NO. 664-7-06455		SCALE	1:1
MATERIAL		CODE		ISSUE No.	2	DR.	SIH
SPEC		FORM		DATE	04JAN06		
FINISH		PATTERN No.					A06455B1



HDM58 - OPTIONS (metric series)

Code	Description	Notes
WAVEFORM (WINDING)		
Y00-A*	Waveform	Sinusoidal waveform
FEEDBACK DEVICES		
F00-C*	Resolver (F00 setting)	2 Pole Resolver type 15-B with F00 setting
F66-A	No Feedback device fitted	
FITTED ENCODERS		
E28-B	Incremental Encoder	Renco R35i, 2048ppr
E30-B	Incremental Encoder	Renco R35i, 4098ppr
E31-C	Incremental Encoder	Renco R35i, 8192ppr
E--**	Alternative Heidenhain and Stegmann absolute encoders and Heidenhain incremental encoder are available on request please contact SEM for further details	
MECHANICAL INTERFACE		
M00-Q*	Flange	58 x 58 mm square flange. Spigot Ø 40mm. Fixing 4 x Ø 4.5 mm holes on 63 mm PCD
R01-A	Close tolerance interface	Flange & shaft to IEC72-P (precision)
S00-G*	Shaft	Ø 9mm x 20mm long
K00-N*	Keyway	3 x 3 x 12 mm long, Enclosed.
K99-A	No Keyway	Plain shaft
D01-E	Shaft end threaded hole	M3 x 10mm deep
D99-A	No Shaft end threaded hole	
BRAKES		
B00-G	HDM58A + C, 24Vdc Brake	1.0 Nm. Torque, Spring Applied
B00-H	HDM58E + G, 24Vdc Brake	2.0 Nm. Torque, Permanent Magnet
ELECTRICAL TERMINATIONS		
C00-D*	Motor & feedback connector	M17 motor receptacle (7 pin) and feedback receptacle (17 pin) facing NDE
C70	Flying leads	Motor and feedback leads, C70A 0.5m long, C70B 1m long, C70C 1.5m long, C70D 2 m long.
C83-A	Motor plug	M17 straight plug (7 pin) to suit option C00
C83-B	Feedback plug	M17 straight plug (17 pin) to suit option C00
THERMAL PROTECTION		
P18-A*	No thermal overload	Thermal protection not fitted
ENCLOSURE PROTECTION		
W02-H*	IP64/65 enclosure	Nitrile shaft seal for IP64/65 protection (supplied loose)
W00-H	IP64/65 enclosure	Nitrile shaft seal for IP64/65 protection (factory fitted)
W99-A	No Shaft Seal Fitted	

*Standard feature

**Alternative encoder available please contact SEM for further information

HDM82A8

HDM82C8

HDM82E8

HDM82J8

HDM82

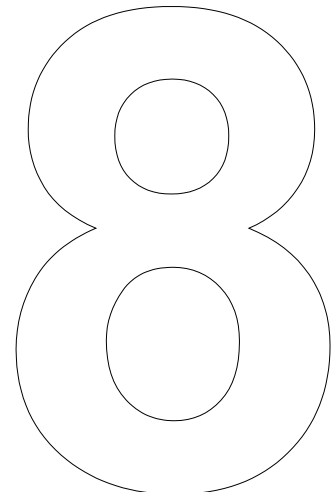

8.1 HDM82A8

HDM COMPACT SERVOMOTORS

Outline Drawing.

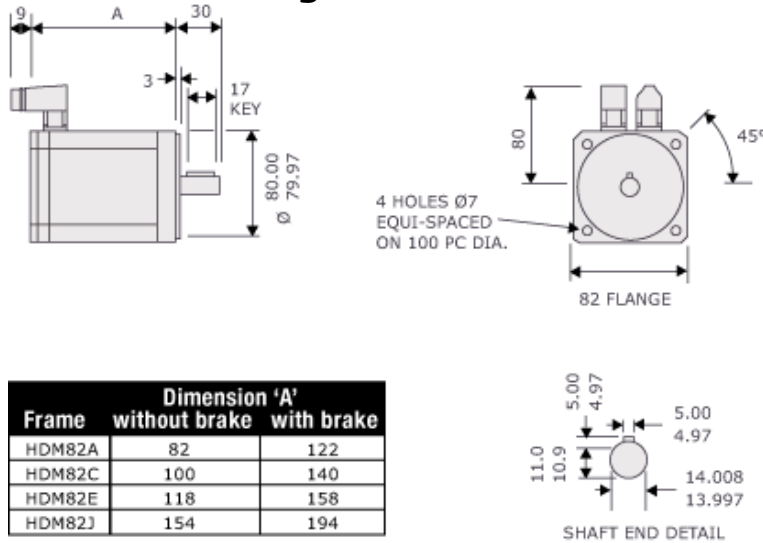

Frame	Dimension 'A'	
	without brake	with brake
HDM82A	82	122
HDM82C	100	140
HDM82E	118	158
HDM82J	154	194

Technical Data.

Parameter	Units	HDM82 A8-15S	HDM82 A8-30S	HDM82 A8-47S
Continuous Stall Torque ¹	Nm	0.84	0.84	0.84
Continuous Stall Current ¹	A	4.8	2.4	1.5
Rated Torque ¹	Nm	0.8	0.8	0.8
Rated Current ¹	A	4.7	2.3	1.5
Rated Speed	rpm	4500	4500	4500
Max. Speed (300V DC link)	rpm	8000	8000	6400
Max. Speed (560V DC link) ²	rpm	-----	-----	8000
Peak Stall Torque	Nm	2.2	2.2	2.2
Peak Current	A	22	11.2	7.1
Resistance Line-Line ³	Ω	1.13	4.5	11.2
Inductance Line-Line ⁴	mH	2	8	20
Voltage Gradient No Load	V	15	30	47
Max. Motor EMF Line - Line	Volts	120	240	380
Torque Constant Kt ^{3,5}	Nm/A	0.17	0.35	0.54
Number of Poles		8	8	8
THERMAL				
Insulation Class		F	F	F
Max. Ambient Temperature	°C	40	40	40
Thermal Time Constant	minutes	20	20	20
Thermal Resistance	°C/W	1.8	1.8	1.8
MECHANICAL				
Rotor Polar Moment of Inertia	kgcm ²	0.35	0.35	0.35
Static Friction Torque	Nm	0.04	0.04	0.04
Cogging Torque	Nm	0.028	0.028	0.028
Motor Weight	kg	1.7	1.7	1.7
Motor Weight with brake fitted	kg	TBA	TBA	TBA
Continuous Stall Torque (HR/HJ) ⁶	Nm	0.74	0.74	0.74

Notes

- ¹ - Motors are tested on an aluminium heatsink with dimensions 255x255x6mm and with a temperature rise ΔT of 100K on the windings. The maximum temperature of the windings is therefore 140°C.
- ² - Where no motor speed is specified, optimal performance may not be achieved on 560V DC link.
- ³ - At 25°C.
- ⁴ - Inductance values are based on nominal current.
- ⁵ - At rated values Torque = $K_t \times \text{rms current}$.
- ⁶ - Continuous Stall Torque (HR/HJ) is for use in comparisons with SEM's HR and HJ servomotors only.

HDM82A8
ON 150V
WITHOUT SHAFT SEAL

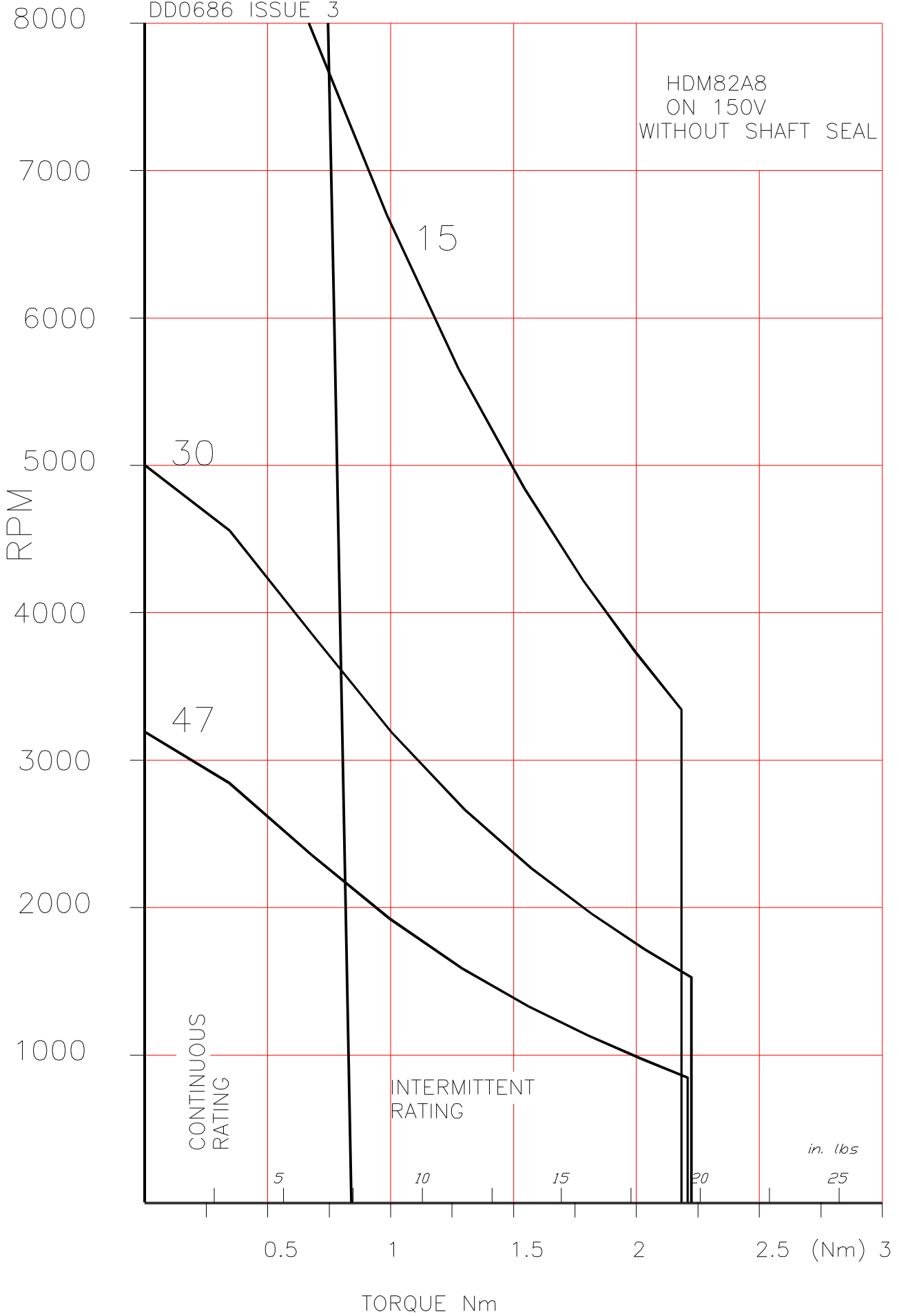

in. lbs

TORQUE Nm

HDM82A8
ON 300V
WITHOUT SHAFT SEAL

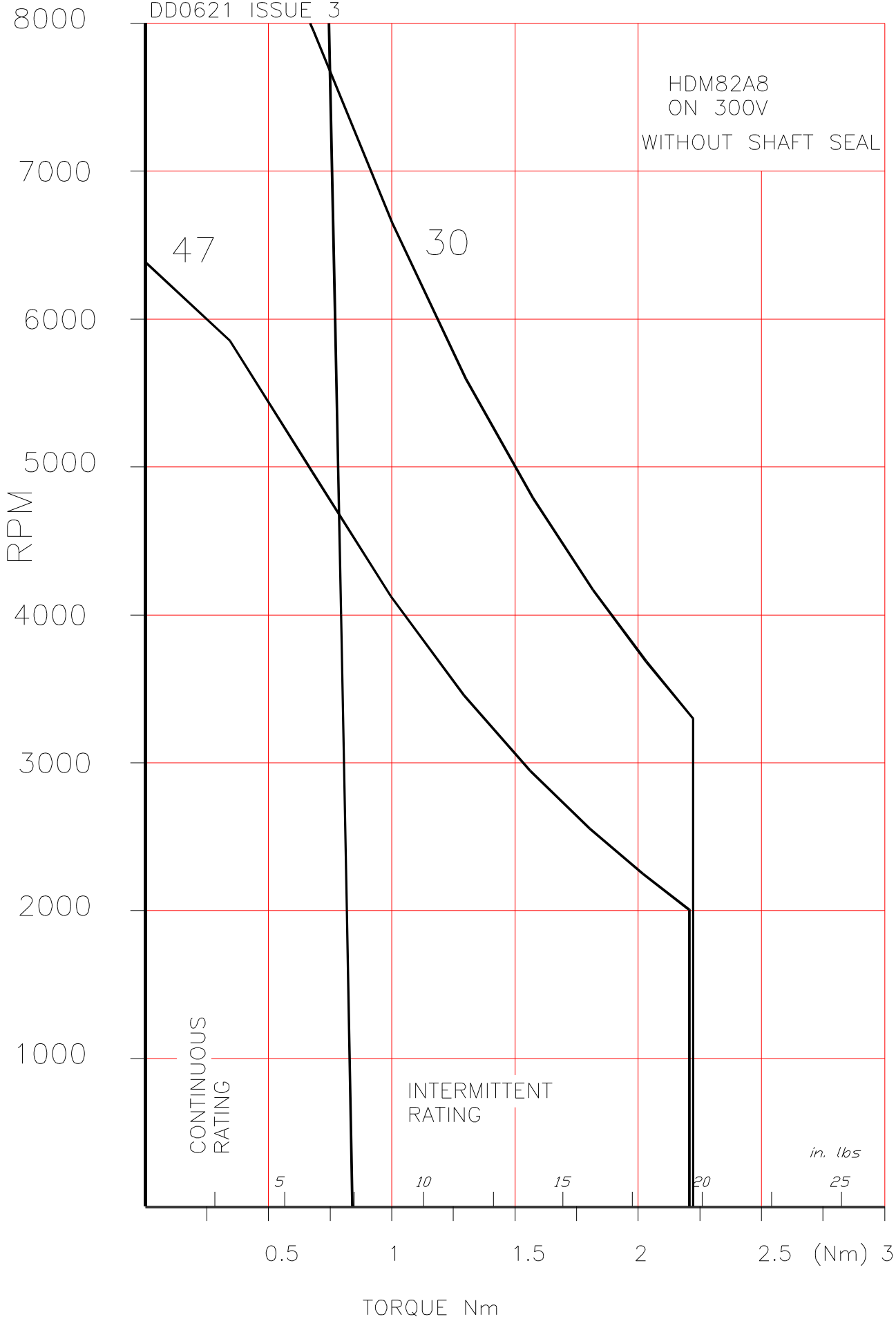

in. lbs

TORQUE Nm

DD0626 ISSUE 3

HDM82A8
ON 560V
WITHOUT SHAFT SEAL

47

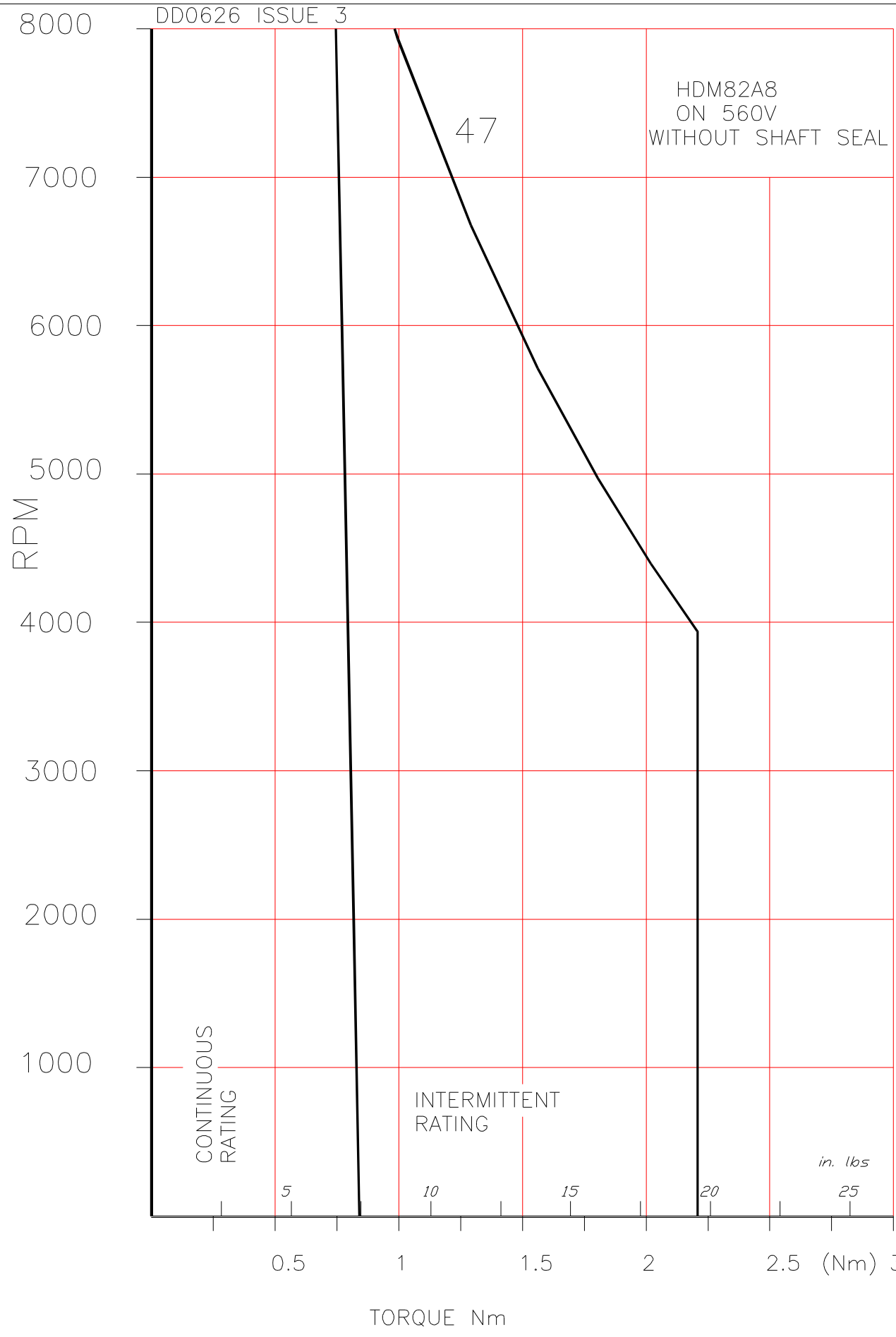

CONTINUOUS
RATING

INTERMITTENT
RATING

in. lbs

5 10 15 20 25

0.5 1 1.5 2 2.5 (Nm) 3

TORQUE Nm

DD0694 ISSUE 3

HDM82A8
ON 650V
WITHOUT SHAFT SEAL

47

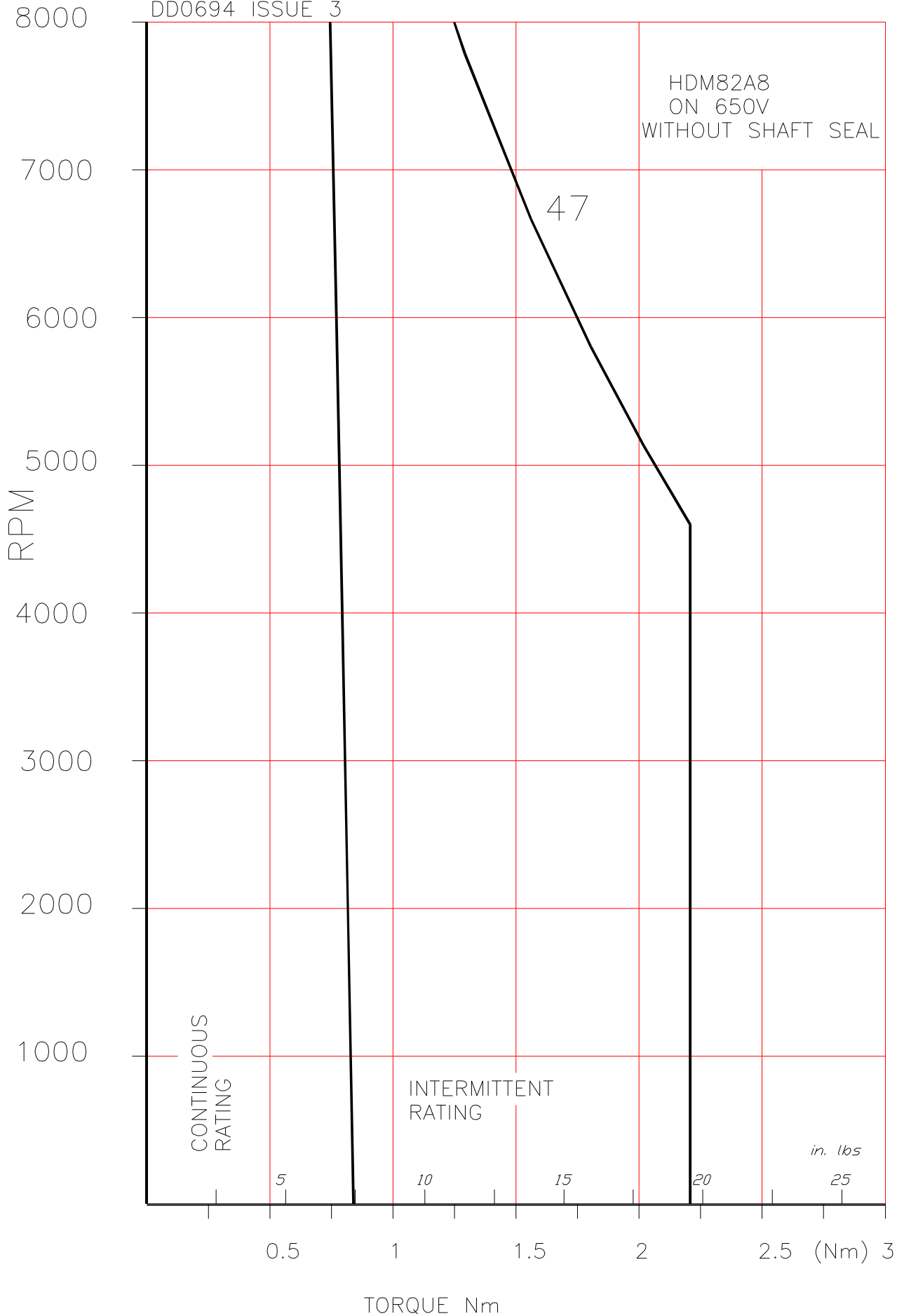

8.2 HDM82C8

HDM COMPACT SERVOMOTORS

Outline Drawing.

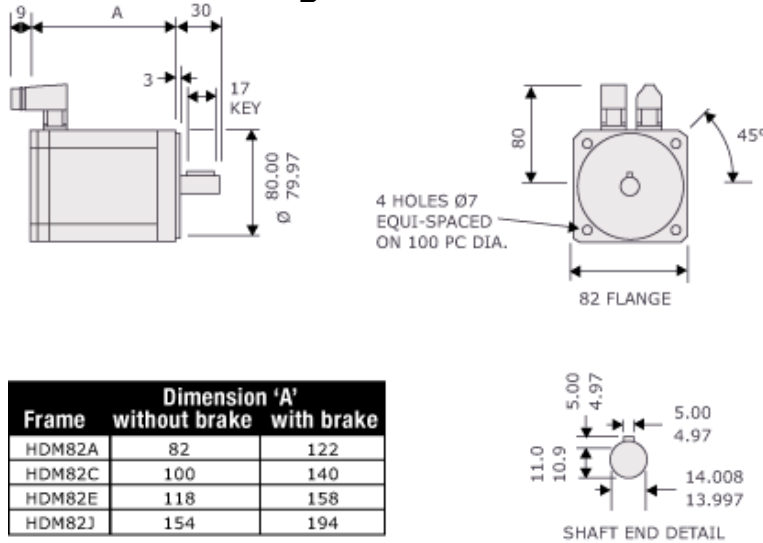

Frame	Dimension 'A'	
	without brake	with brake
HDM82A	82	122
HDM82C	100	140
HDM82E	118	158
HDM82J	154	194

Technical Data.

Parameter	Units	HDM82 C8-22S	HDM82 C8-28S	HDM82 C8-63S
Continuous Stall Torque ¹	Nm	1.7	1.7	1.7
Continuous Stall Current ¹	A	6.6	5.2	2.3
Rated Torque ¹	Nm	1.6	1.6	1.6
Rated Current ¹	A	6.2	4.8	2.1
Rated Speed	rpm	4500	4500	4500
Max. Speed (300V DC link)	rpm	8000	8000	4800
Max. Speed (560V DC link) ²	rpm	-----	-----	8000
Peak Stall Torque	Nm	4.6	4.6	4.6
Peak Current	A	32	25	11
Resistance Line-Line ³	Ω	0.83	1.37	7
Inductance Line-Line ⁴	mH	1.8	3	15
Voltage Gradient No Load	V	22	28	63
Max. Motor EMF Line – Line	Volts	180	220	500
Torque Constant Kt ^{3,5}	Nm/A	0.26	0.33	0.75
Number of Poles		8	8	8
THERMAL				
Insulation Class		F	F	F
Max. Ambient Temperature	°C	40	40	40
Thermal Time Constant	minutes	23	23	23
Thermal Resistance	°C/W	1.24	1.24	1.24
MECHANICAL				
Rotor Polar Moment of Inertia	kgcm ²	0.61	0.61	0.61
Static Friction Torque	Nm	0.04	0.04	0.04
Cogging Torque	Nm	0.05	0.05	0.05
Motor Weight	kg	2.3	2.3	2.3
Motor Weight with brake fitted	kg	TBA	TBA	TBA
Continuous Stall Torque (HR/HJ) ⁶	Nm	1.55	1.55	1.55

Notes

- ¹ - Motors are tested on an aluminium heatsink with dimensions 255x255x6mm and with a temperature rise ΔT of 100K on the windings. The maximum temperature of the windings is therefore 140°C.
- ² - Where no motor speed is specified, optimal performance may not be achieved on 560V DC link.
- ³ - At 25°C.
- ⁴ - Inductance values are based on nominal current.
- ⁵ - At rated values Torque = Kt x rms current.
- ⁶ - Continuous Stall Torque (HR/HJ) is for use in comparisons with SEM's HR and HJ servomotors only.

HDM82C8
ON 150V
WITHOUT SHAFT SEAL

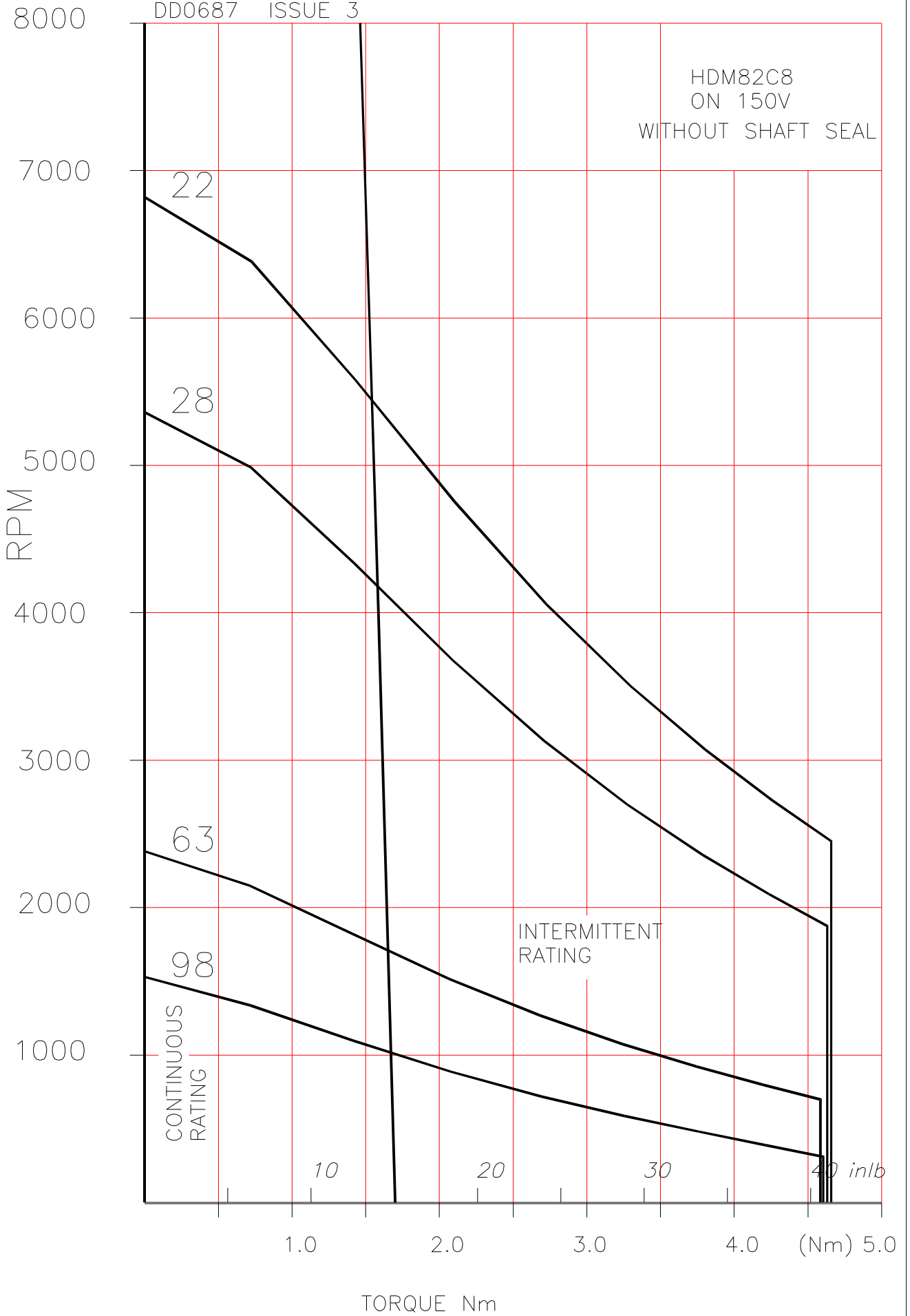

HDM82C8
ON 300V
WITHOUT SHAFT SEAL

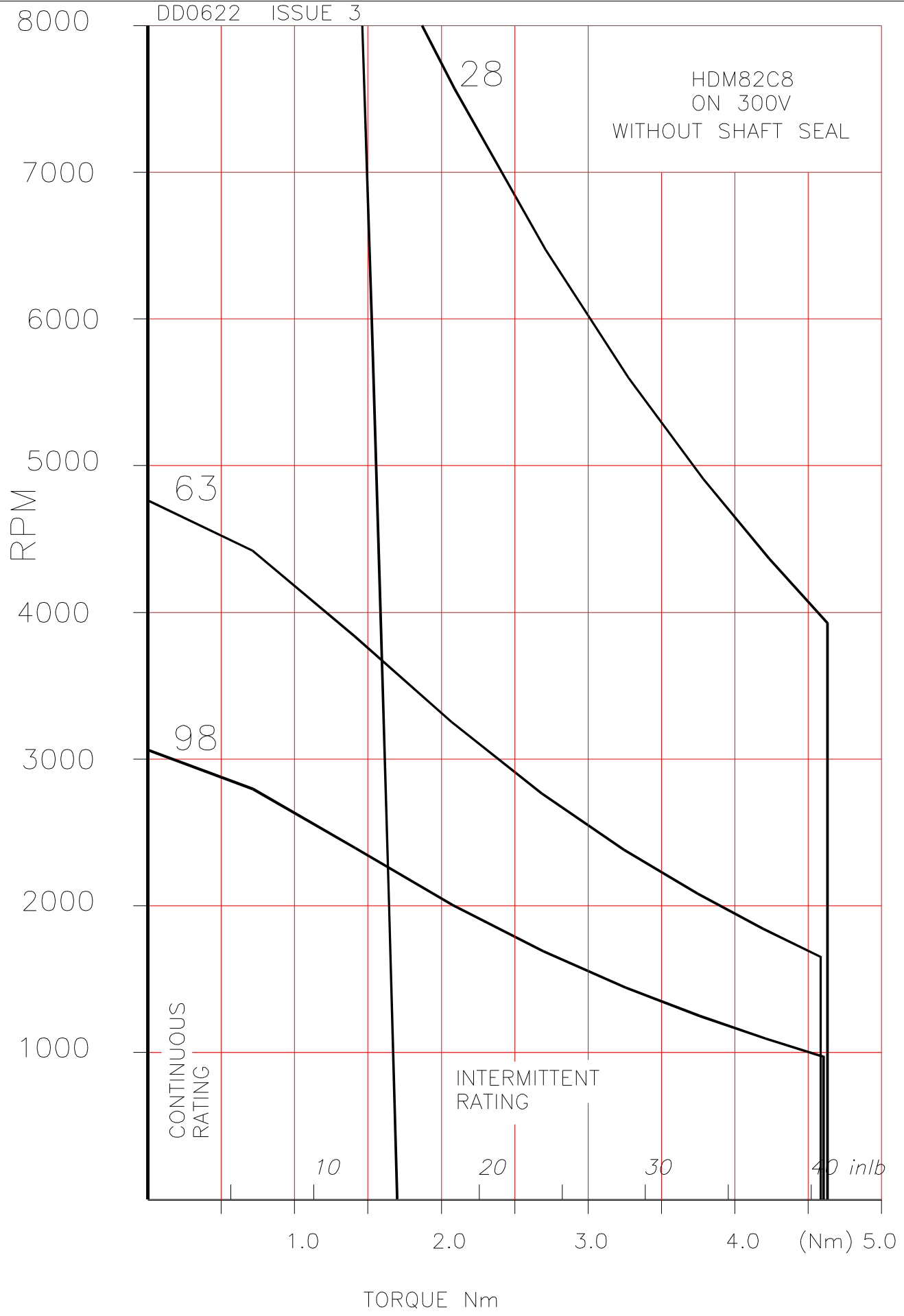

DD0627 ISSUE 3

HDM82C8
ON 560V
WITHOUT SHAFT SEAL

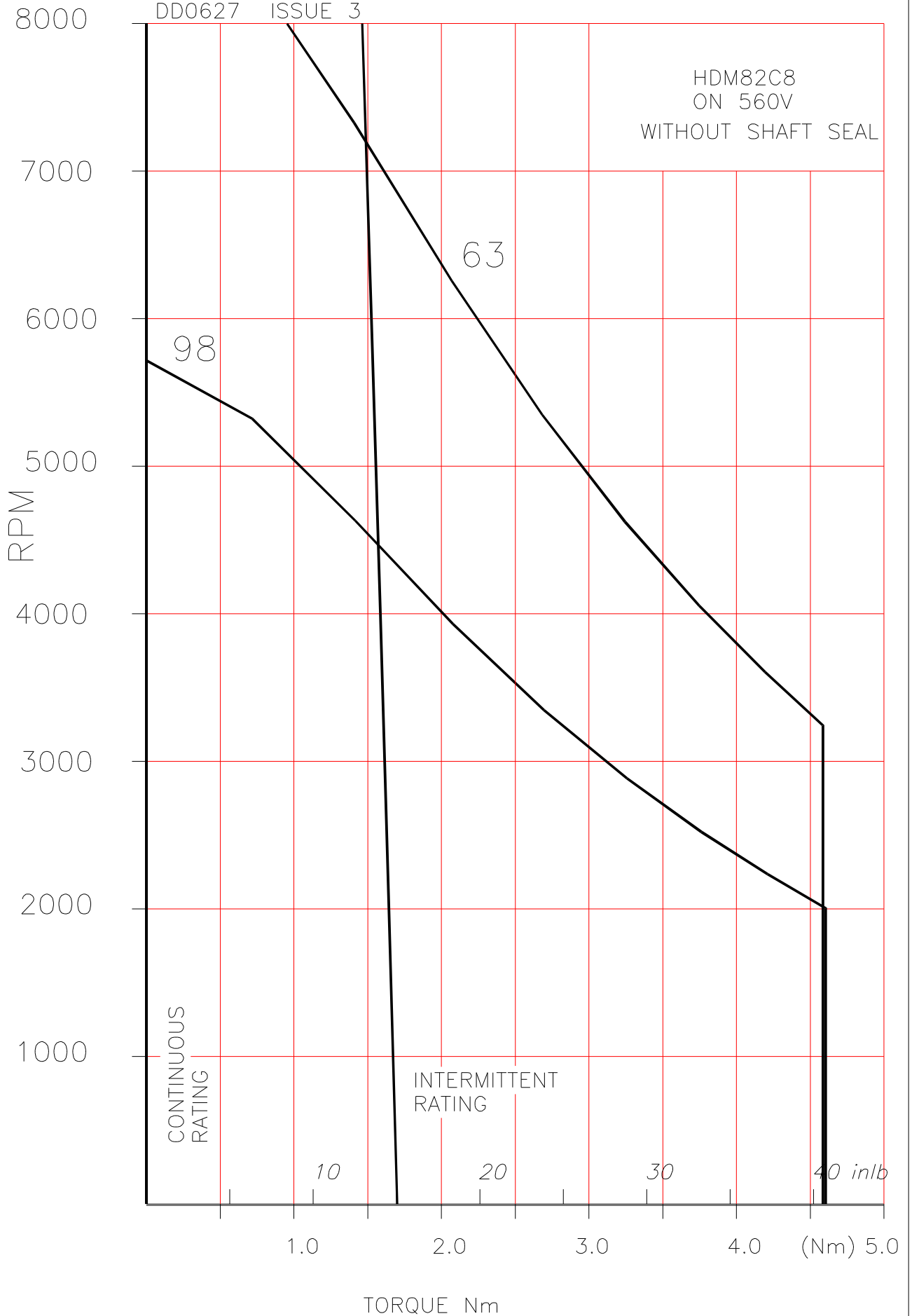

HDM82C8
ON 650V
WITHOUT SHAFT SEAL

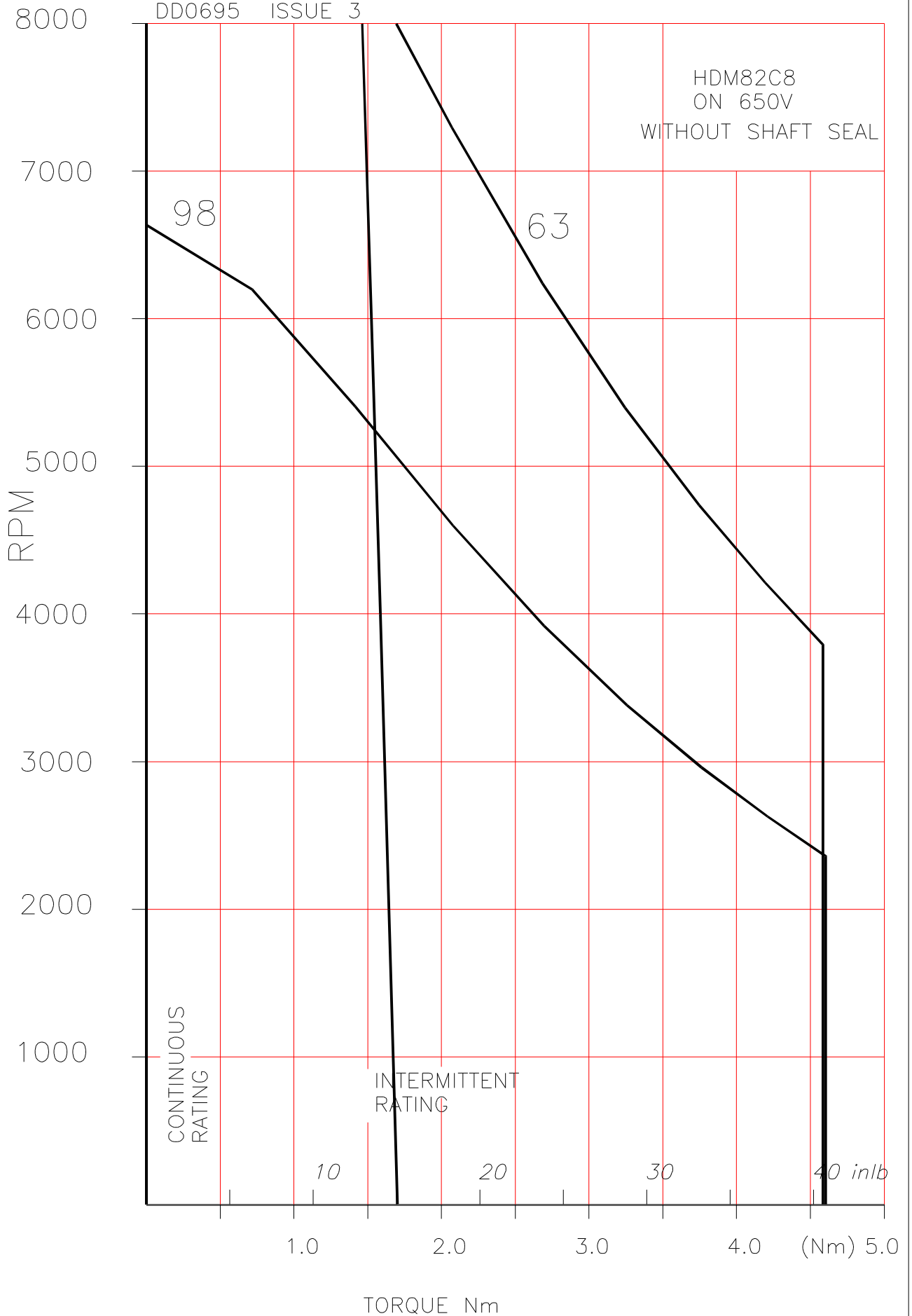

8.3 HDM82E8

HDM COMPACT SERVOMOTORS

Outline Drawing.

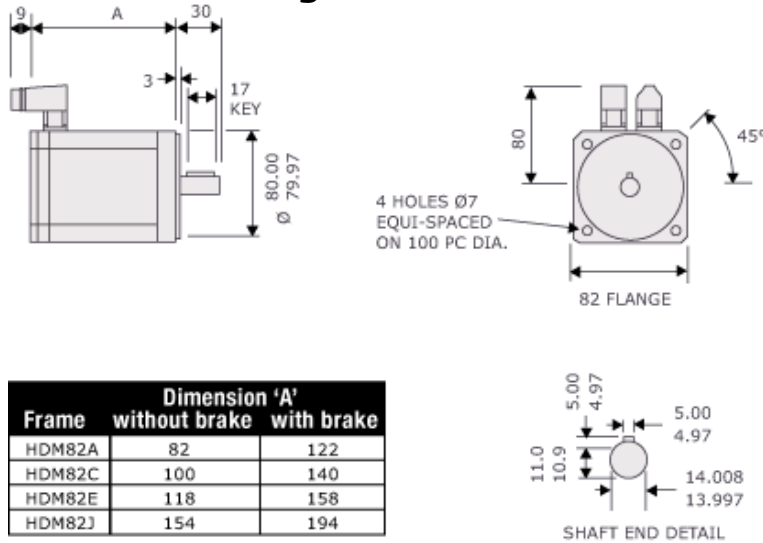

Frame	Dimension 'A'	
	without brake	with brake
HDM82A	82	122
HDM82C	100	140
HDM82E	118	158
HDM82J	154	194

Technical Data.

Parameter	Units	HDM82 E8-30S	HDM82 E8-38S	HDM82 E8-76S
Continuous Stall Torque ¹	Nm	2.3	2.3	2.3
Continuous Stall Current ¹	A	6.6	5.2	2.6
Rated Torque ¹	Nm	2.1	2.1	2.1
Rated Current ¹	A	6	4.7	2.3
Rated Speed	rpm	4500	4500	3000
Max. Speed (300V DC link)	rpm	8000	7800	3900
Max. Speed (560V DC link) ²	rpm	-----	-----	7300
Peak Stall Torque	Nm	6.9	6.9	6.9
Peak Current	A	35	28	14
Resistance Line-Line ³	Ω	0.91	1.5	5.8
Inductance Line-Line ⁴	mH	2.2	3.4	13.5
Voltage Gradient No Load	V	30	38	76
Max. Motor EMF Line – Line	Volts	240	300	610
Torque Constant Kt ^{3,5}	Nm/A	0.35	0.45	0.9
Number of Poles		8	8	8
THERMAL				
Insulation Class		F	F	F
Max. Ambient Temperature	°C	40	40	40
Thermal Time Constant	minutes	26	26	26
Thermal Resistance	°C/W	1.18	1.18	1.18
MECHANICAL				
Rotor Polar Moment of Inertia	kgcm ²	0.88	0.88	0.88
Static Friction Torque	Nm	0.04	0.04	0.04
Cogging Torque	Nm	0.075	0.075	0.075
Motor Weight	kg	2.9	2.9	2.9
Motor Weight with brake fitted	kg	TBA	TBA	TBA
Continuous Stall Torque (HR/HJ) ⁶	Nm	2.2	2.2	2.2

Notes

- ¹ - Motors are tested on an aluminium heatsink with dimensions 255x255x6mm and with a temperature rise ΔT of 100K on the windings. The maximum temperature of the windings is therefore 140°C.
- ² - Where no motor speed is specified, optimal performance may not be achieved on 560V DC link.
- ³ - At 25°C.
- ⁴ - Inductance values based on nominal current.
- ⁵ - At rated values Torque = Kt x rms current.
- ⁶ - Continuous Stall Torque (HR/HJ) is for use in comparisons with SEM's HR and HJ servomotors only.

HDM82E8
ON 150V
WITHOUT SHAFT SEAL

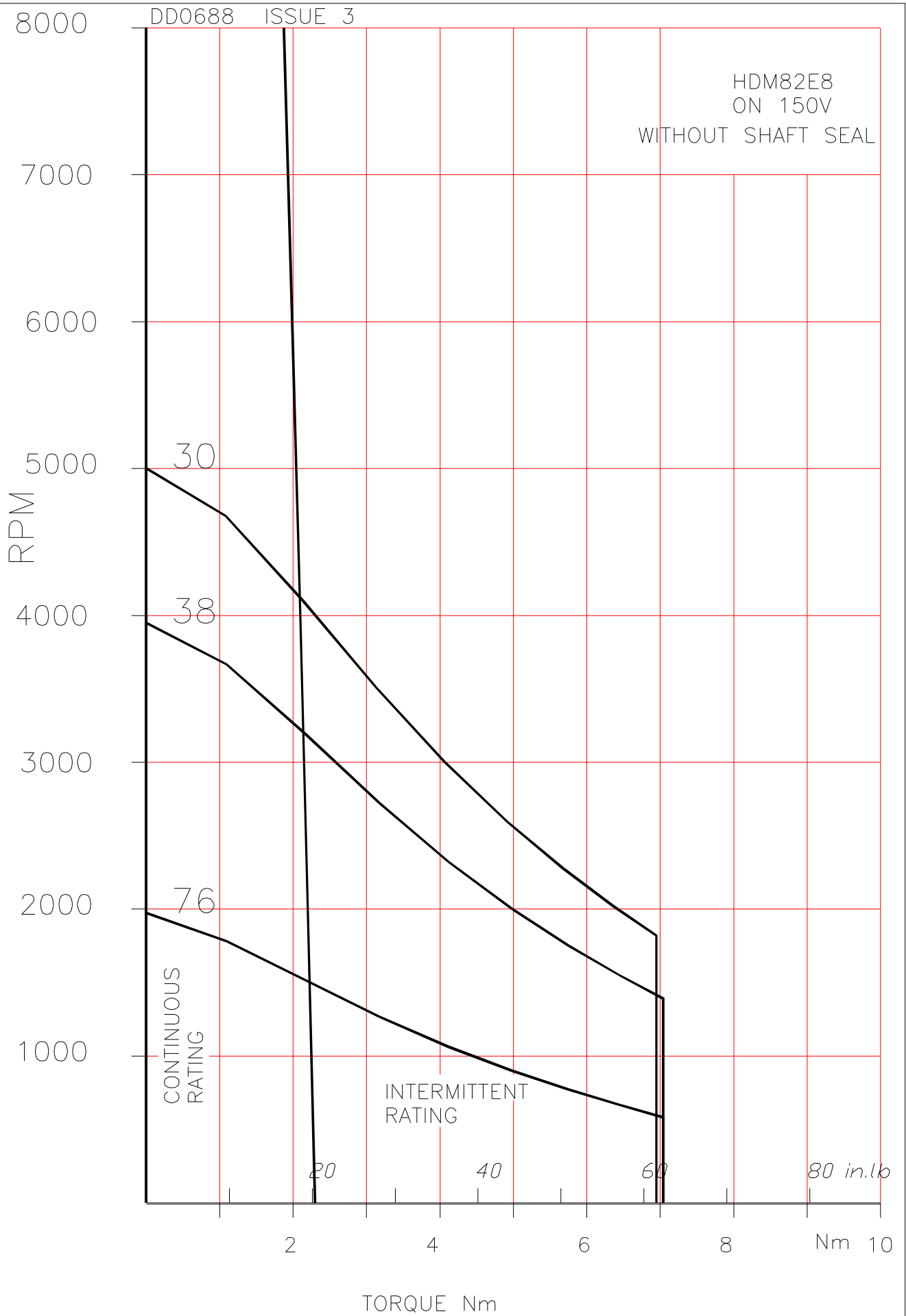

DD0623 ISSUE 3

HDM82E8
ON 300V
WITHOUT SHAFT SEAL

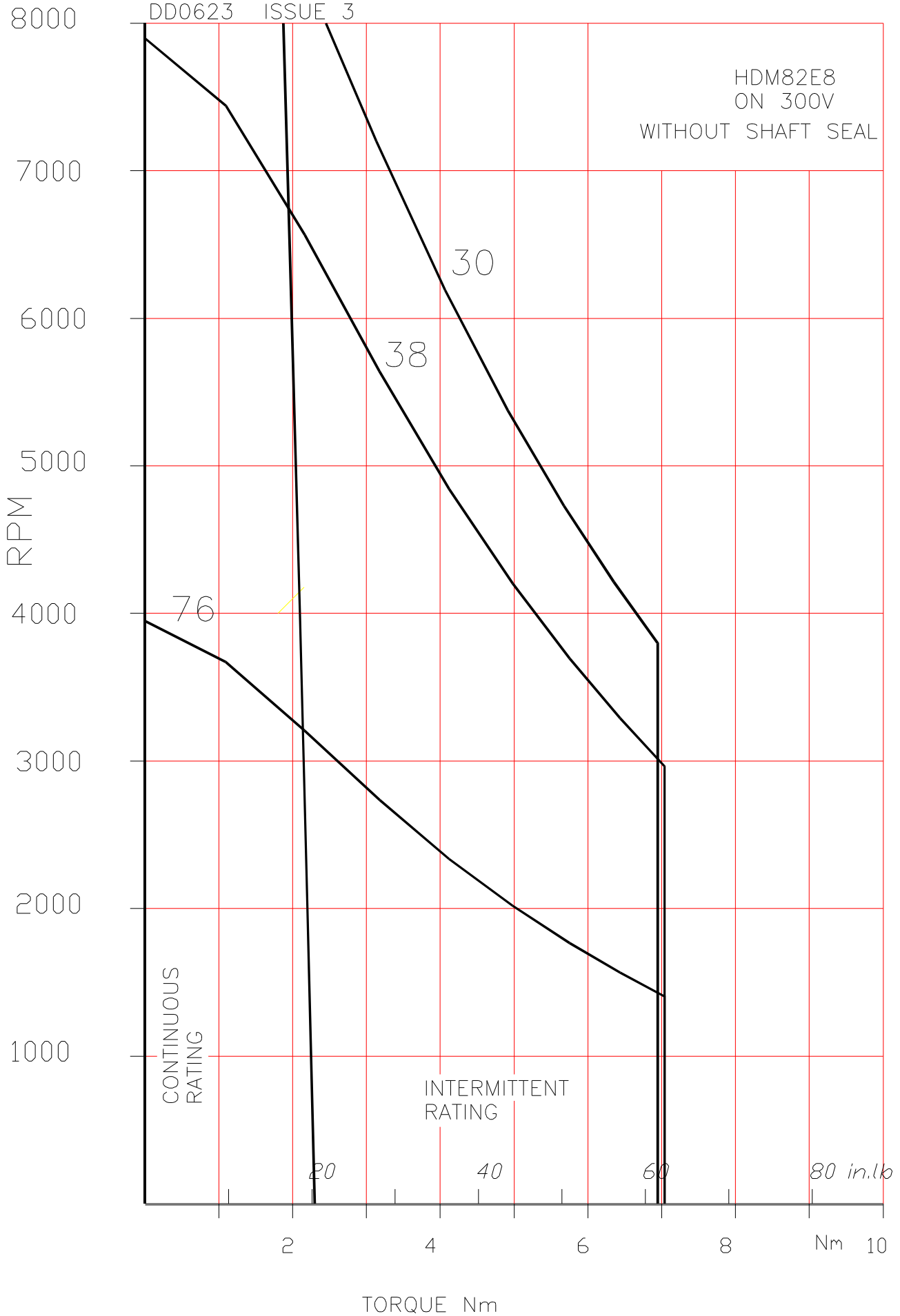

DD0628 ISSUE 3

HDM82E8
ON 560V
WITHOUT SHAFT SEAL

8000

76

7000

6000

5000

4000

3000

2000

1000

RPM

CONTINUOUS
RATING

INTERMITTENT
RATING

20

40

60

80 in.lb

2

4

6

8

Nm

10

TORQUE Nm

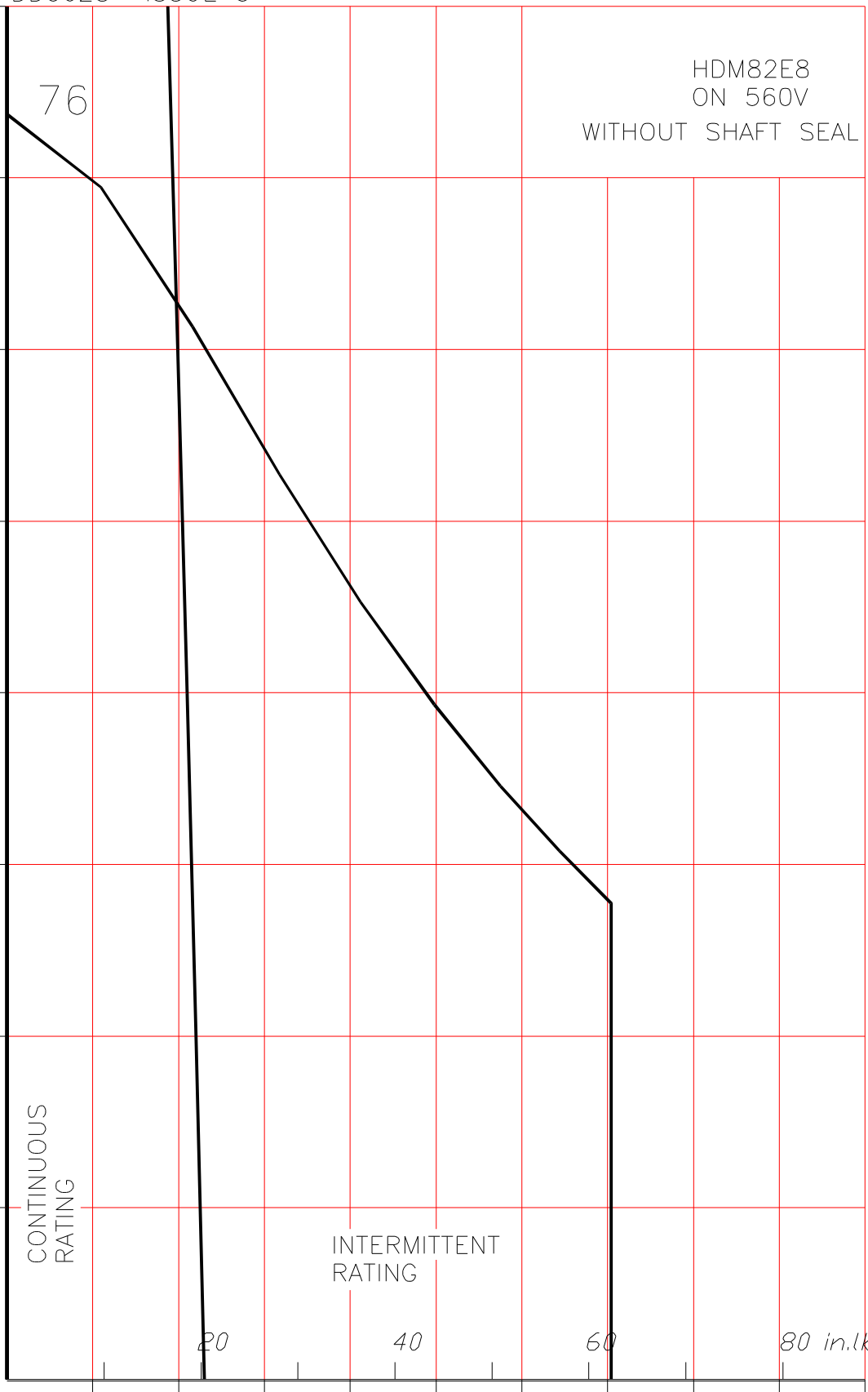

DD0696 ISSUE 3

HDM82E8
ON 650V
WITHOUT SHAFT SEAL

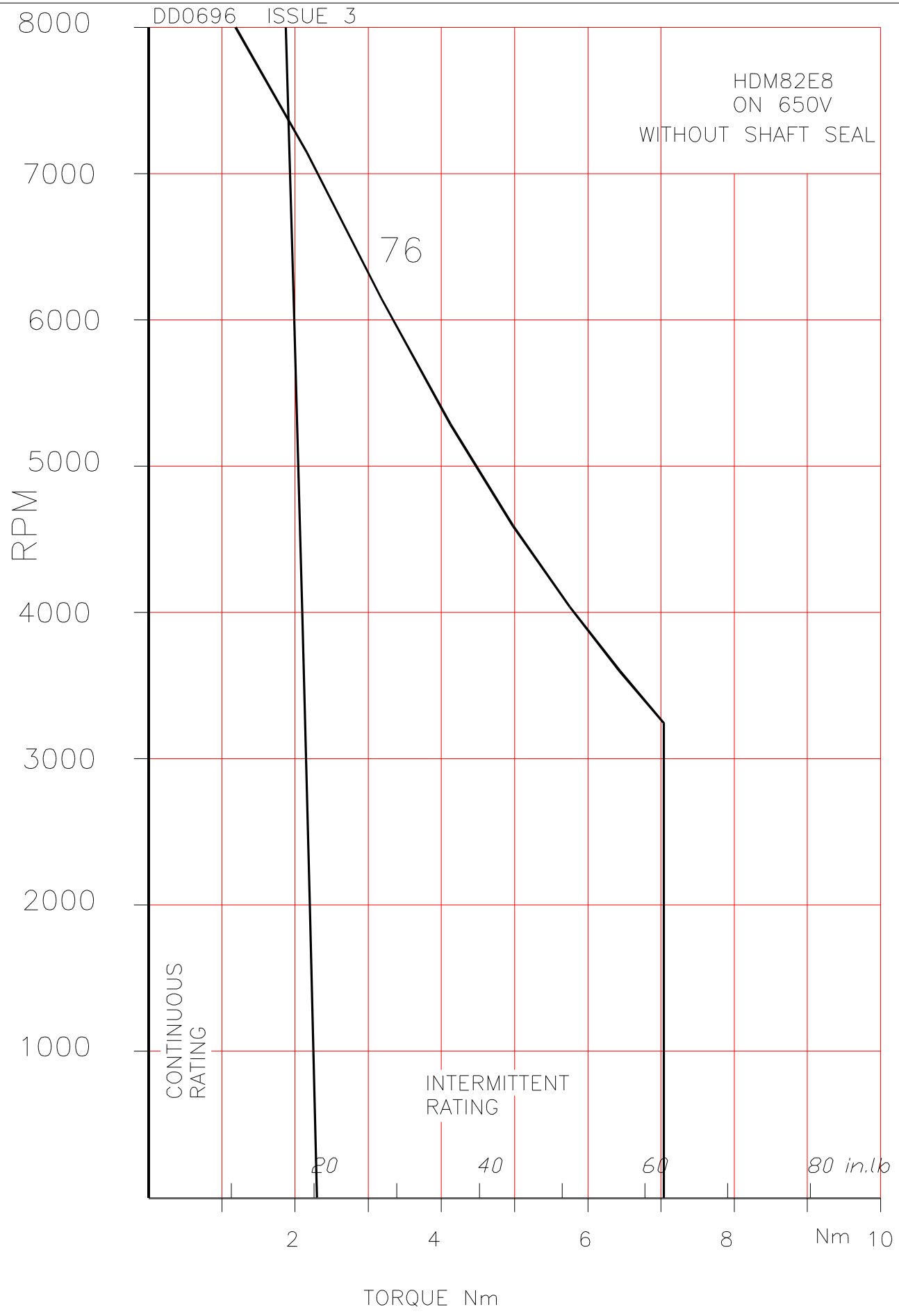

8.4 HDM82J8

HDM COMPACT SERVOMOTORS

Outline Drawing.

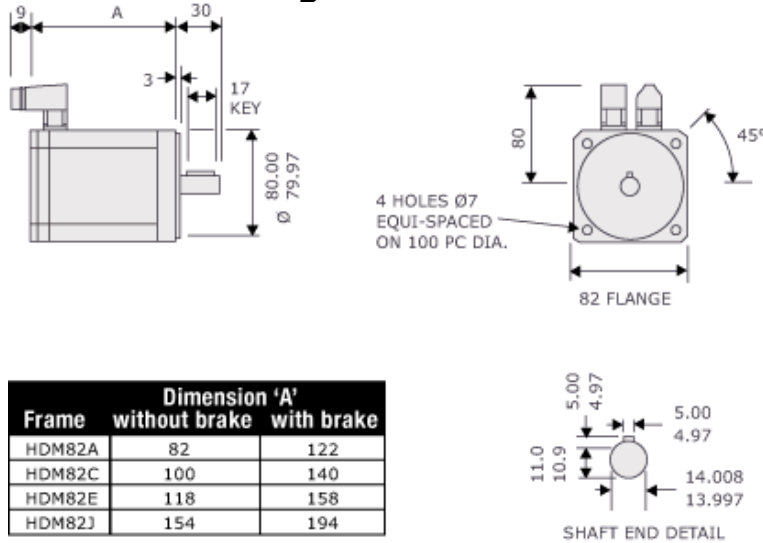

Frame	Dimension 'A'	
	without brake	with brake
HDM82A	82	122
HDM82C	100	140
HDM82E	118	158
HDM82J	154	194

Technical Data.

Parameter	Units	HDM82 J8-40S	HDM82 J8-56S	HDM82 J8-116S
Continuous Stall Torque ¹	Nm	3.5	3.5	3.5
Continuous Stall Current ¹	A	7.5	5.3	2.6
Rated Torque ¹	Nm	2.6	2.6	2.6
Rated Current ¹	A	5.4	3.9	1.9
Rated Speed	rpm	4500	4500	4500
Max. Speed (300V DC link)	rpm	7300	5300	2600
Max. Speed (560V DC link) ²	rpm	-----	8000	4800
Peak Stall Torque	Nm	11.6	11.6	11.6
Peak Current	A	44	32	15
Resistance Line-Line ³	Ω	0.89	1.7	7.1
Inductance Line-Line ⁴	mH	2.2	4.2	18.5
Voltage Gradient No Load	V	40	56	116
Max. Motor EMF Line - Line	Volts	320	450	700
Torque Constant Kt ^{3,5}	Nm/A	0.48	0.66	1.35
Number of Poles		8	8	8
THERMAL				
Insulation Class		F	F	F
Max. Ambient Temperature	°C	40	40	40
Thermal Time Constant	minutes	30	30	30
Thermal Resistance	°C/W	0.95	0.95	0.95
MECHANICAL				
Rotor Polar Moment of Inertia	kgcm ²	1.4	1.4	1.4
Static Friction Torque	Nm	0.04	0.04	0.04
Cogging Torque	Nm	0.11	0.11	0.11
Motor Weight	kg	4	4	4
Motor Weight with brake fitted	kg	TBA	TBA	TBA
Continuous Stall Torque (HR/HJ) ⁶	Nm	3.2	3.2	3.2

Notes

- ¹ - Motors are tested on an aluminium heatsink with dimensions 255x255x6mm and with a temperature rise ΔT of 100K on the windings. The maximum temperature of the windings is therefore 140°C.
- ² - Where no motor speed is specified, optimal performance may not be achieved on 560V DC link.
- ³ - At 25°C.
- ⁴ - Inductance values are based on nominal current.
- ⁵ - At rated values Torque = $K_t \times \text{rms current}$.
- ⁶ - Continuous Stall Torque (HR/HJ) is for use in comparisons with SEM's HR and HJ servomotors only.

HDM82J8
on 150 VOLT
WITHOUT SHAFT SEAL



HDM82J8
on 300 VOLT
WITHOUT SHAFT SEAL

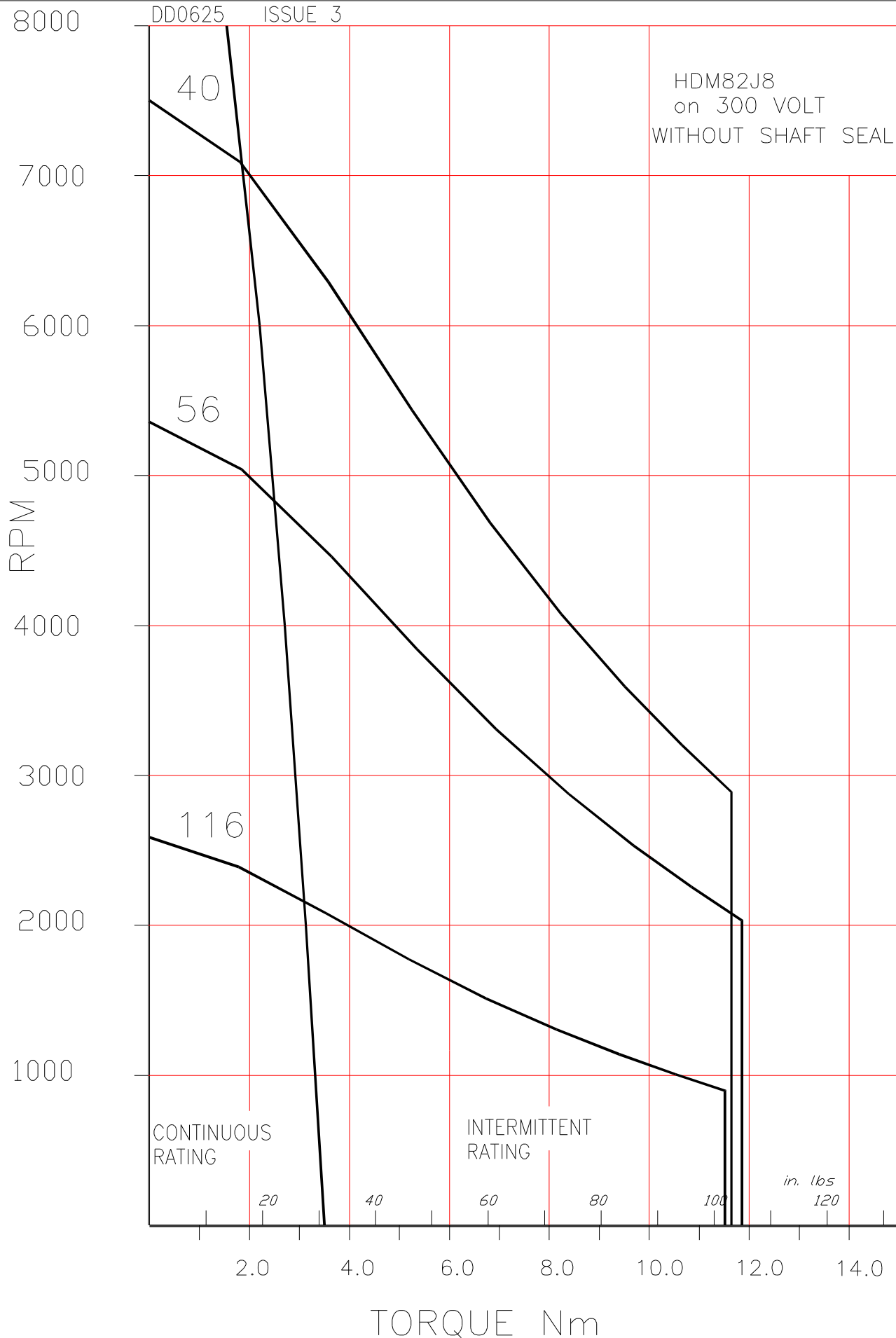

DD0629 ISSUE 3

HDM82J8
on 560 VOLT
WITHOUT SHAFT SEAL

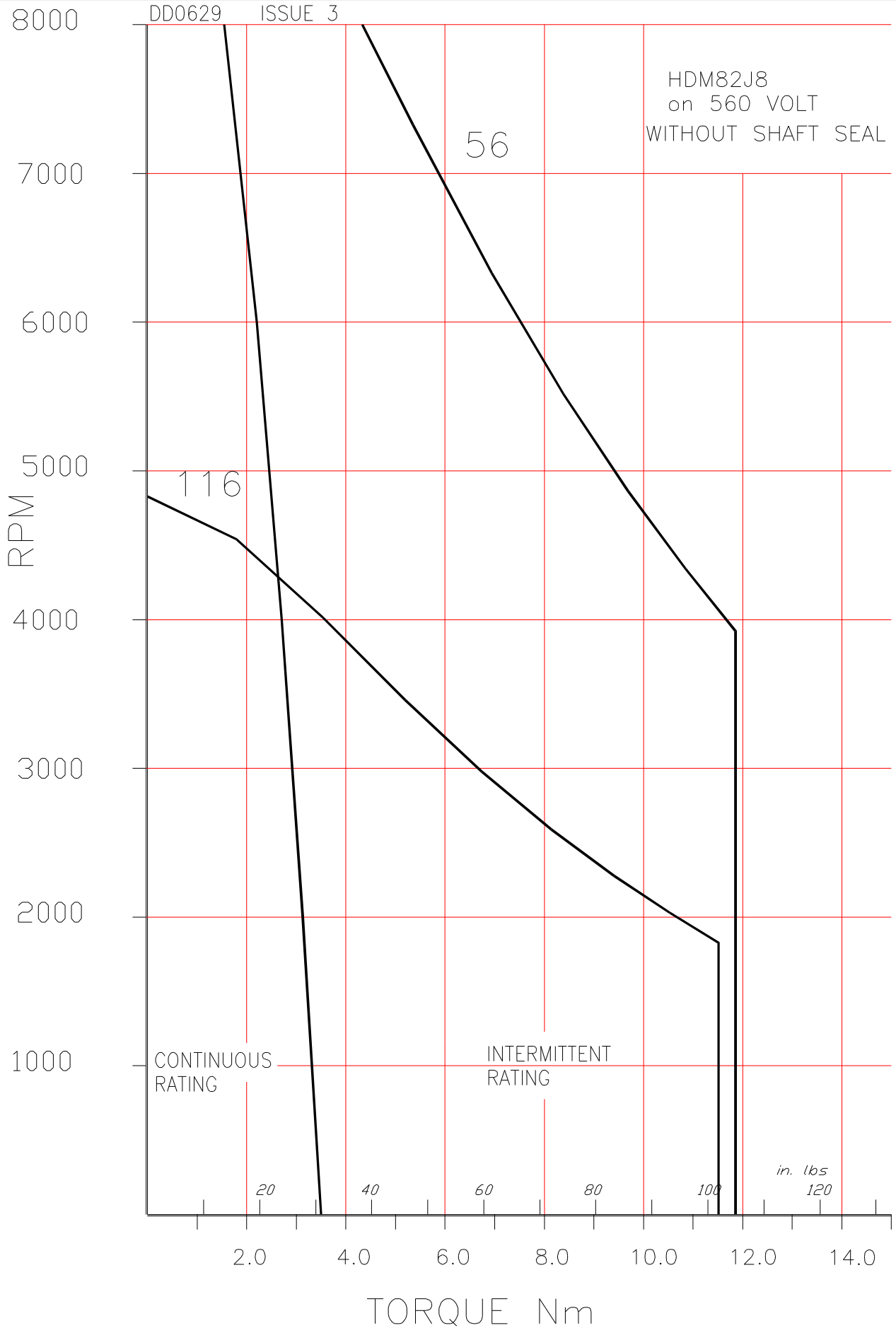

CONTINUOUS RATING

INTERMITTENT RATING

20 40 60 80 100 *in. lbs* 120

TORQUE Nm

DD0697 ISSUE 3

HDM82J8
on 650 VOLT
WITHOUT SHAFT SEAL

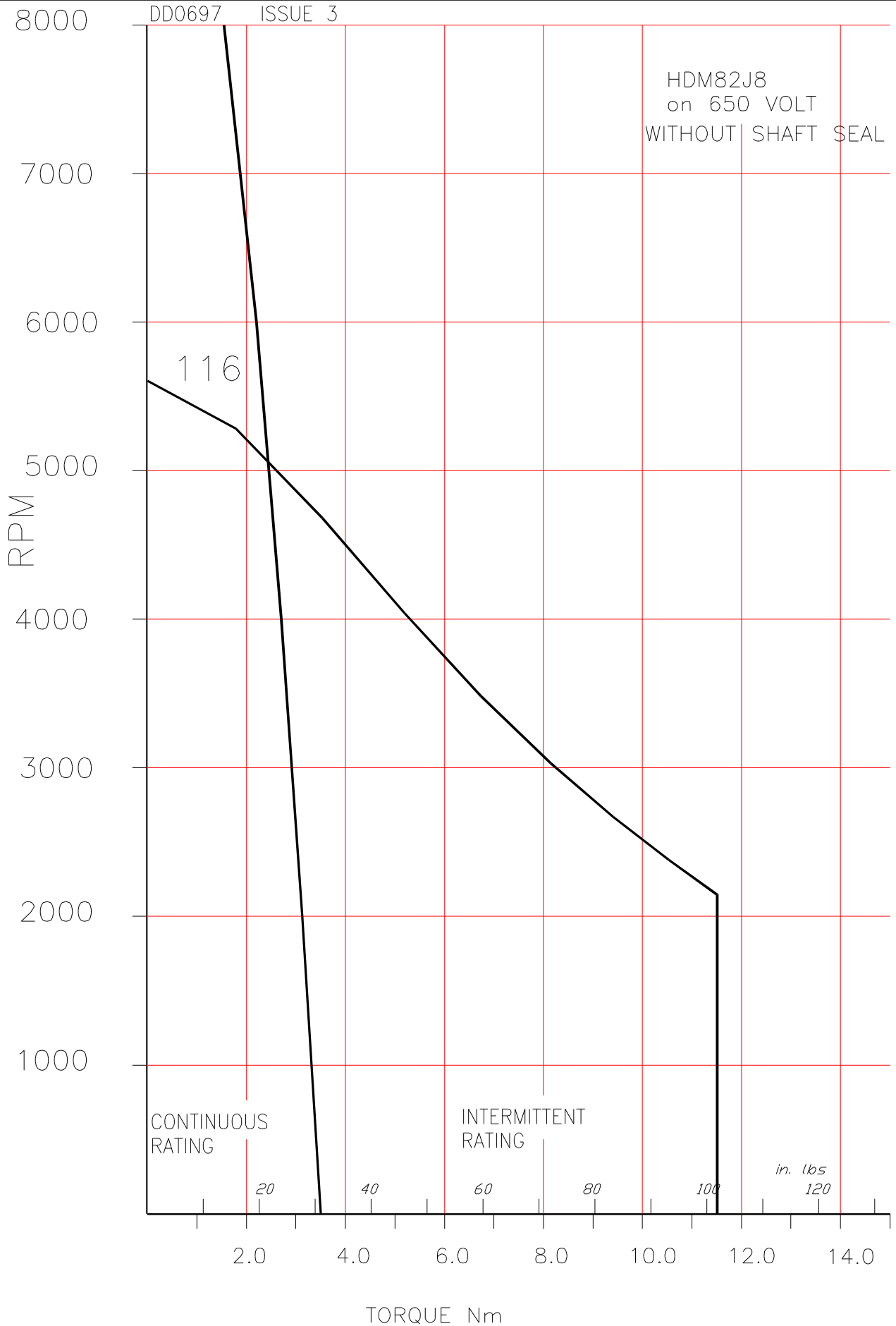

HDM82 PERMITTED RADIAL SHAFT LOADINGS

(Axial loading may be considered separately - refer to next page)

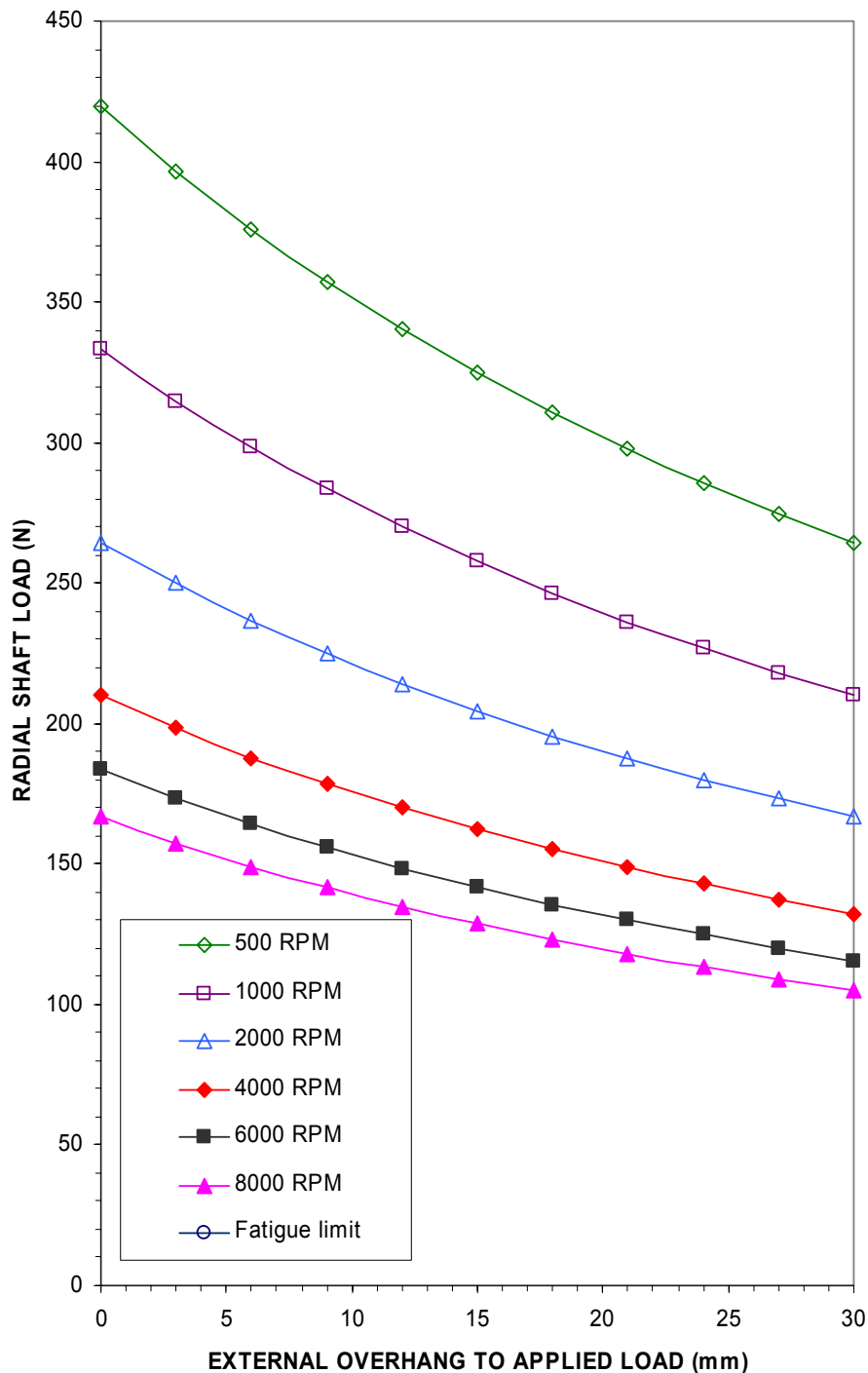

Shaft Loading Information for SEM Standard Servomotors

General notes:-

1 All loadings are based upon An L10 bearing life expectancy of 30,000 hours.

2 Separate graphs are usually supplied to indicate maximum axial loads which are applicable. However, for motors with locked drive end bearings, a graph is used to illustrate the maximum allowed radial shaft loadings together with a simplified calculation to provide a compensated figure for when radial and axial loadings are to be applied in combination.

3 It may occur, in certain circumstances, that loading outside the scope of the published information is deemed necessary. In these cases it is desirable that SEM Ltd should be consulted and all relevant information made available, in order that due consideration can be given to finding a satisfactory solution.

4 Should motors be required to operate under abnormal conditions, such as excessive vibration or shock, this should also be referred to SEM Ltd as noted above.

HDM82 PERMITTED AXIAL LOAD

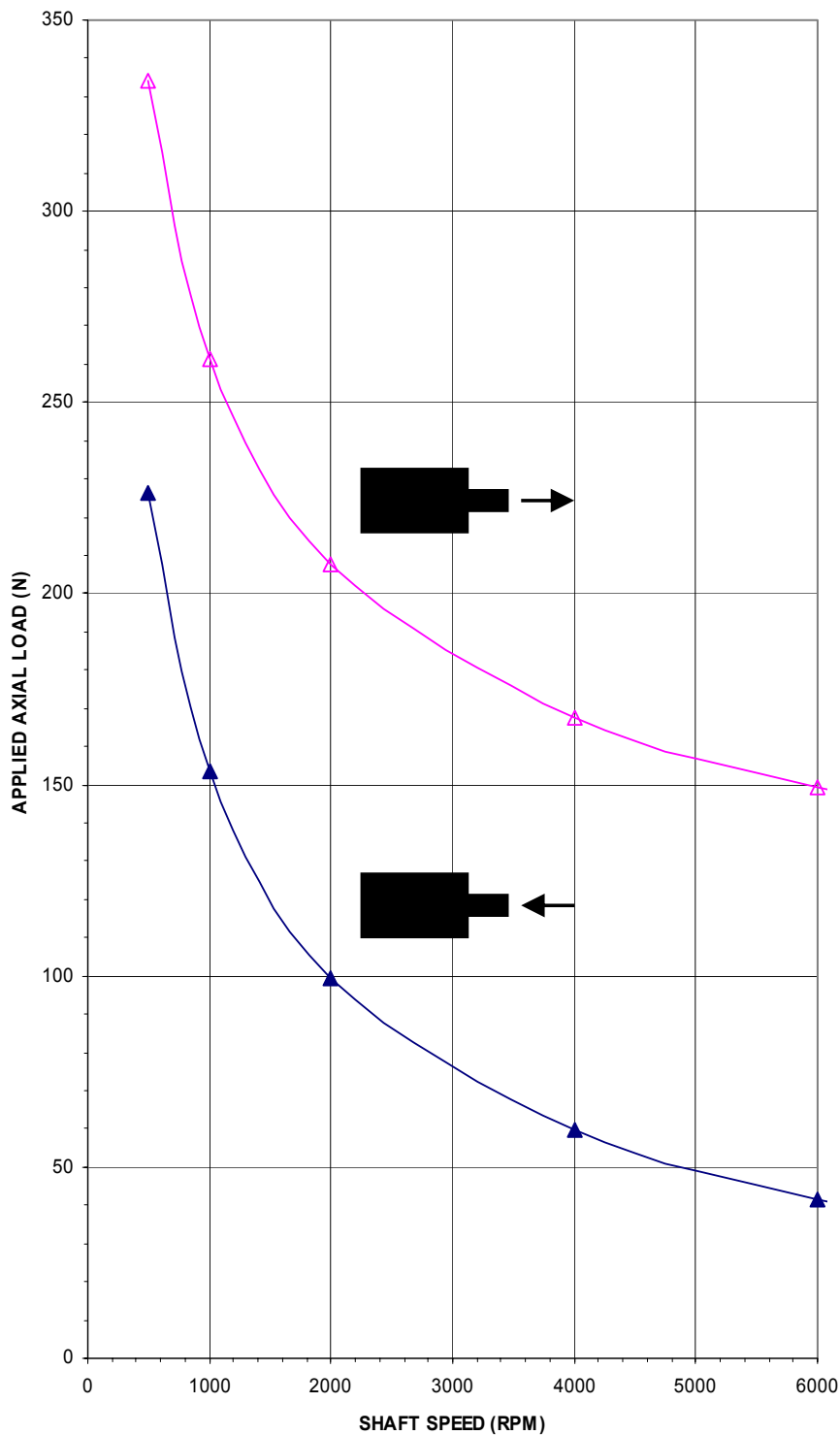

Shaft Loading Information for SEM Standard Servomotors

General notes:-

- 1 All loadings are based upon An L10 bearing life expectancy of 30,000 hours.
- 2 Separate graphs are usually supplied to indicate maximum axial loads which are applicable. However, for motors with locked drive end bearings, a graph is used to illustrate the maximum allowed radial shaft loadings together with a simplified calculation to provide a compensated figure for when radial and axial loadings are to be applied in combination.
- 3 It may occur, in certain circumstances, that loading outside the scope of the published information is deemed necessary. In these cases it is desirable that SEM Ltd should be consulted and all relevant information made available, in order that due consideration can be given to finding a satisfactory solution.
- 4 Should motors be required to operate under abnormal conditions, such as excessive vibration or shock, this should also be referred to SEM Ltd as noted above.

FIRST ANGLE PROJECTION

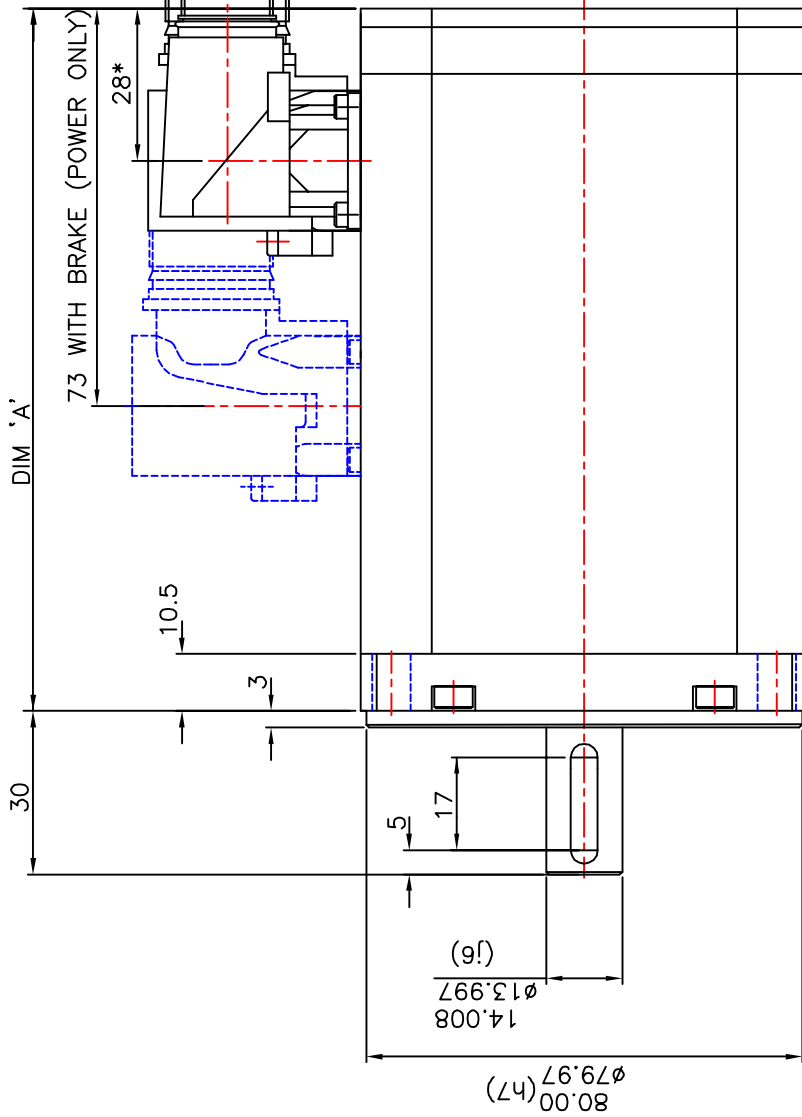

*F/B CONNECTOR BRAKE & NON BRAKE, POWER CONNECTOR NON BRAKE

FRAME	DIM 'A'	NO BRAKE	WITH BRAKE
HDM82A	82	122	
HDM82C	100	140	
HDM82E	118	158	
HDM82J	154	194	

4-FIXING HOLES Ø7 EQUI-SPACED ON 100 PCD

KEYWAY DETAIL

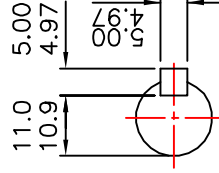

FOR CONNECTORS FACING DE SEE 664-7-06548

2 12JUL06 MR3798 CONNECTORS CHANGED OVER
3 12MAR07 MR4005 F/B CONNECTOR ON BRAKE MOTOR MOVED

TITLE: HDM82 STD MET WITH M23 & M17 CONNS FACING NDE

DRAWING NO.	SCALE	1:1
664-7-06498	ISSUE No.	3
	DR.	PFS
	DATE	22MAY06
	A06498C1	



ALL DIMENSIONS IN MILLIMETRES
TOLERANCES UNLESS ANG: ±0.5°
OTHERWISE STATED DIM: ±0.25mm

MATERIAL	AS STATED	CODE
SPEC		FORM
FINISH		PATTERN No.

HDM82 - OPTIONS (metric series)

Code	Description	Notes
WAVEFORM (WINDING)		
Y00-A*	Waveform	Sinusoidal waveform
FEEDBACK DEVICES		
F00-C*	Resolver (F00 setting)	2 Pole Resolver type 15-B with F00 setting
F66-A	No Feedback device fitted	
FITTED ENCODERS		
E28-C	Incremental Encoder	Renco R35i, 2048ppr
E30-C	Incremental Encoder	Renco R35i, 4098ppr
E31-D	Incremental Encoder	Renco R35i, 8192ppr
E15-C	Encoder	Heidenhain ERN1387 series, 2048ppr.
E22-B	Encoder, singleturn, Optical	Heidenhain ECN1313 series, 2048ppr with EnDat Interface.
E16-A	Encoder, multiturn, Optical	Heidenhain EQN1325 series, 2048ppr with EnDat Interface.
E33-A	Encoder, singleturn, Inductive	Heidhenhain EC11319 series, 32ppr with EnDat Interface
E34-A	Encoder, multiturn, Inductive	Heidhenhain EC11331 series, 32ppr with EnDat Interface
MECHANICAL INTERFACE		
M00-O*	Flange	82 x 82 mm square flange. Spigot Ø 80mm. Fixing 4 x Ø 7 mm holes on 100 mm PCD
R01-A	Close tolerance interface	Flange & shaft to IEC72-P (precision)
S00-H*	Shaft	Ø 14mm x 30mm long
K10-E*	Keyway	5 x 5 x 22 mm long, keyway with key enclosed type, also with half key supplied 5 x 2.5 x 22mm long
K99-A	No Keyway	Plain shaft
D01-F*	Shaft end threaded hole	M5 x 15mm deep
D99-A	No Shaft end threaded hole	
BRAKES		
B00-K	24Vdc Brake	4.5 Nm. Torque, Spring Applied
ELECTRICAL TERMINATIONS		
C00-Q*	Motor & feedback connector	Interconnectron size 1 power connector (6 pin) and M17 feedback receptacle (17 pin) facing NDE (resolver and R35i motors)
C48-A	Motor & feedback connector	Interconnectron size 1 power connector (6 pin) and size 1 feedback receptacle (17 pin) facing DE (Heidenhain encoder motors)
C70	Flying leads	Motor and feedback leads, C70-P 0.5m long, C70-Q 1m long, C70-R 1.5m long, C70-S 2.0m long.
C67-A	Motor plug	Interconnectron size 1 straight plug (6 pin) to suit option C00 & C48
C83-E	Feedback plug	M17 straight plug (17 pin) to suit option C00
C69-A	Feedback plug	Interconnectron straight plug (17 pin) to suit option C48
THERMAL PROTECTION		
P17-A*	KTY84-130 Thermal Sensor	
P18-A	No thermal overload	Thermal protection not fitted
ENCLOSURE PROTECTION		
W02-C*	IP64/65 enclosure	Nitrile shaft seal for IP64/65 protection (supplied loose)
W00-C	IP64/65 enclosure	Nitrile shaft seal for IP64/65 protection (factory fitted)
W01-E	IP64/65 enclosure	Viton shaft seal for IP64/65 protection (factory fitted)
W03-H	IP64/65 enclosure	Viton shaft seal for IP64/65 protection (supplied loose)
W99-A	No Shaft Seal Fitted	

*Standard feature

HDM105A10

HDM105C10

HDM105E10

HDM105G10

HDM105

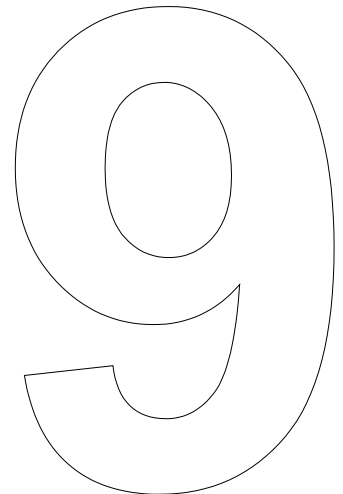

9.1 HDM105A10

HDM COMPACT SERVOMOTORS

Outline Drawing.

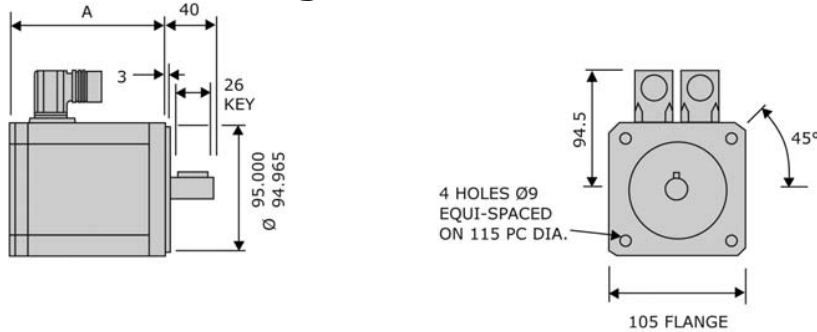

Frame	Dimension 'A'	
	without brake	with brake
HDM105A	94	139
HDM105C	120	165
HDM105E	146	191
HDM105G	172	217

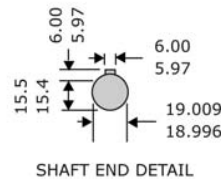

Technical Data.

Parameter	Units	HDM105 A10-31S	HDM105 A10-44S	HDM105 A10-89S
Continuous Stall Torque 1	Nm	2.4	2.4	2.4
Continuous Stall Current 1	A	6.6	4.7	2.3
Rated Torque ¹	Nm	2.2	2.2	2.2
Rated Current ¹	A	6.1	4.3	2.1
Rated Speed	rpm	3000	3000	3000
Max. Speed (300V DC link)	rpm	6000	6000	3300
Max. Speed (560V DC link) ²	rpm	-----	-----	6000
Peak Stall Torque	Nm	5.3	5.3	5.3
Peak Current	A	26	18	9
Resistance Line-Line ³	Ω	1.07	2.1	8.6
Inductance Line-Line ⁴	mH	2.3	4.6	19
Voltage Gradient No Load	V	31	44	89
Max. Motor EMF Line - Line	Volts	190	260	530
Torque Constant Kt ^{3,5}	Nm/A	0.36	0.51	1.05
Number of Poles		10	10	10
THERMAL				
Insulation Class		F	F	F
Max. Ambient Temperature	°C	40	40	40
Thermal Time Constant	minutes	30	30	30
Thermal Resistance	°C/W	1.05	1.05	1.05
MECHANICAL				
Rotor Polar Moment of Inertia	kgcm ²	1.4	1.4	1.4
Static Friction Torque	Nm	0.11	0.11	0.11
Cogging Torque	Nm	0.12	0.12	0.12
Motor Weight	kg	3	3	3
Motor Weight with brake fitted	kg	TBA	TBA	TBA
Continuous Stall Torque (HR/HJ) ⁶	Nm	2.2	2.2	2.2

Notes

- ¹ - Motors are tested on an aluminium heatsink with dimensions 305x305x13mm and with a temperature rise ΔT of 100K on the windings. The maximum temperature of the windings is therefore 140°C.
- ² - Where no motor speed is specified, optimal performance may not be achieved on 560V DC link.
- ³ - At 25°C.
- ⁴ - Inductance values are based on nominal current.
- ⁵ - At rated values Torque = Kt x rms current.
- ⁶ - Continuous Stall Torque (HR/HJ) is for use in comparisons with SEM's HR and HJ servomotors only.

DD0670 ISSUE 3

HDM105A10
on 150 VOLT

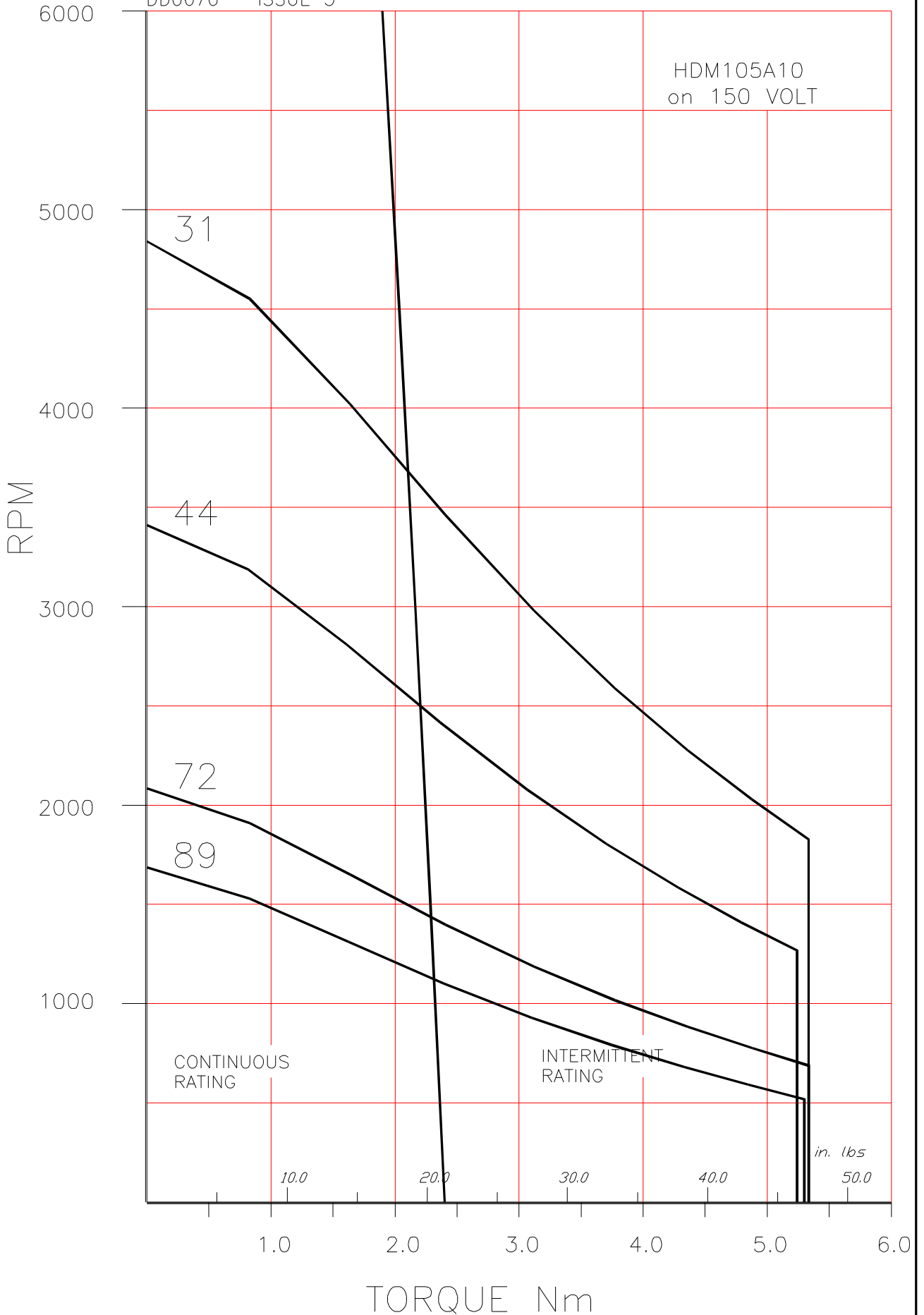

HDM105A10
on 300 VOLT

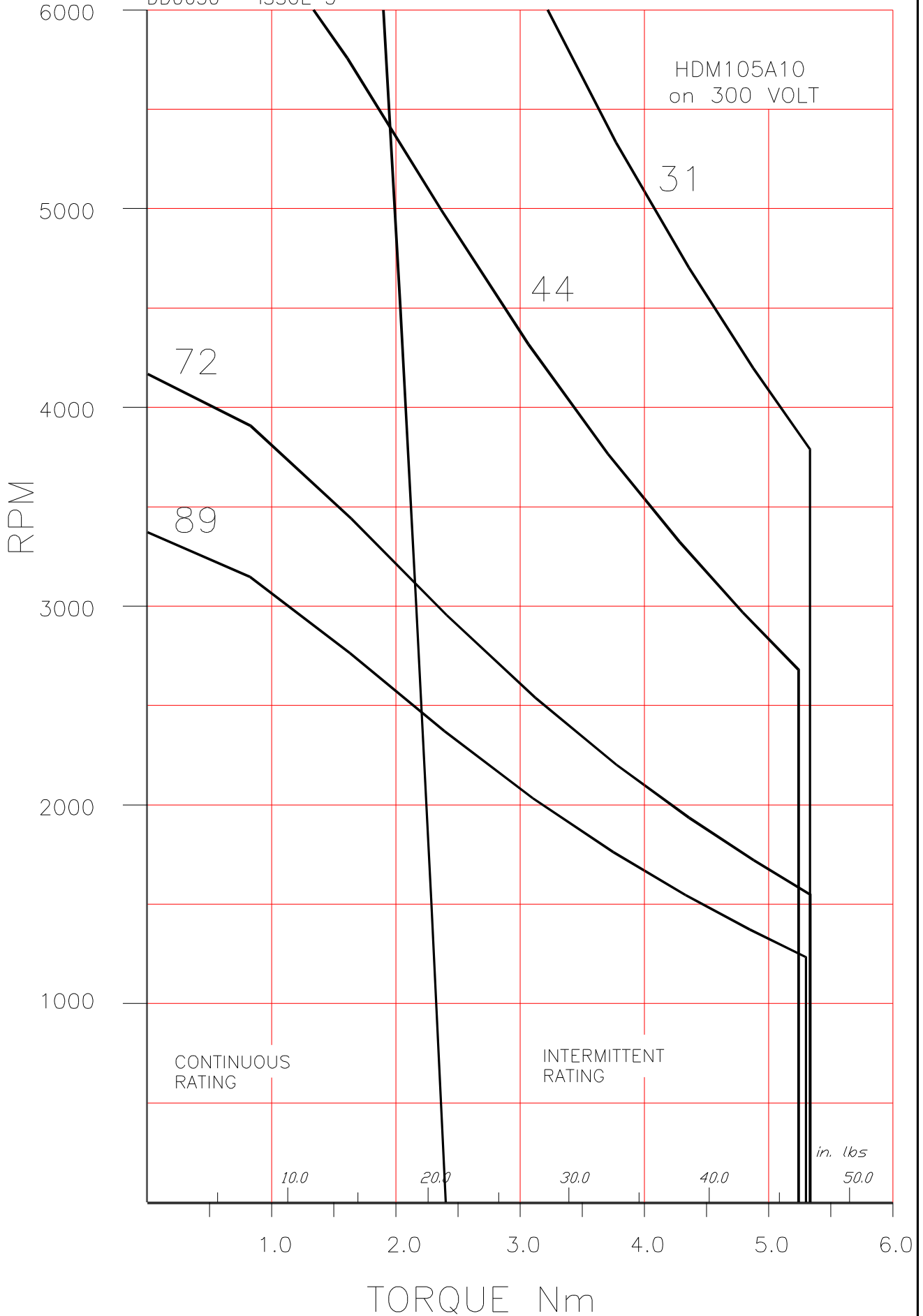

CONTINUOUS
RATING

INTERMITTENT
RATING

in. lbs
50.0

TORQUE Nm

DD0634 ISSUE 3

HDM105A10
on 560 VOLT

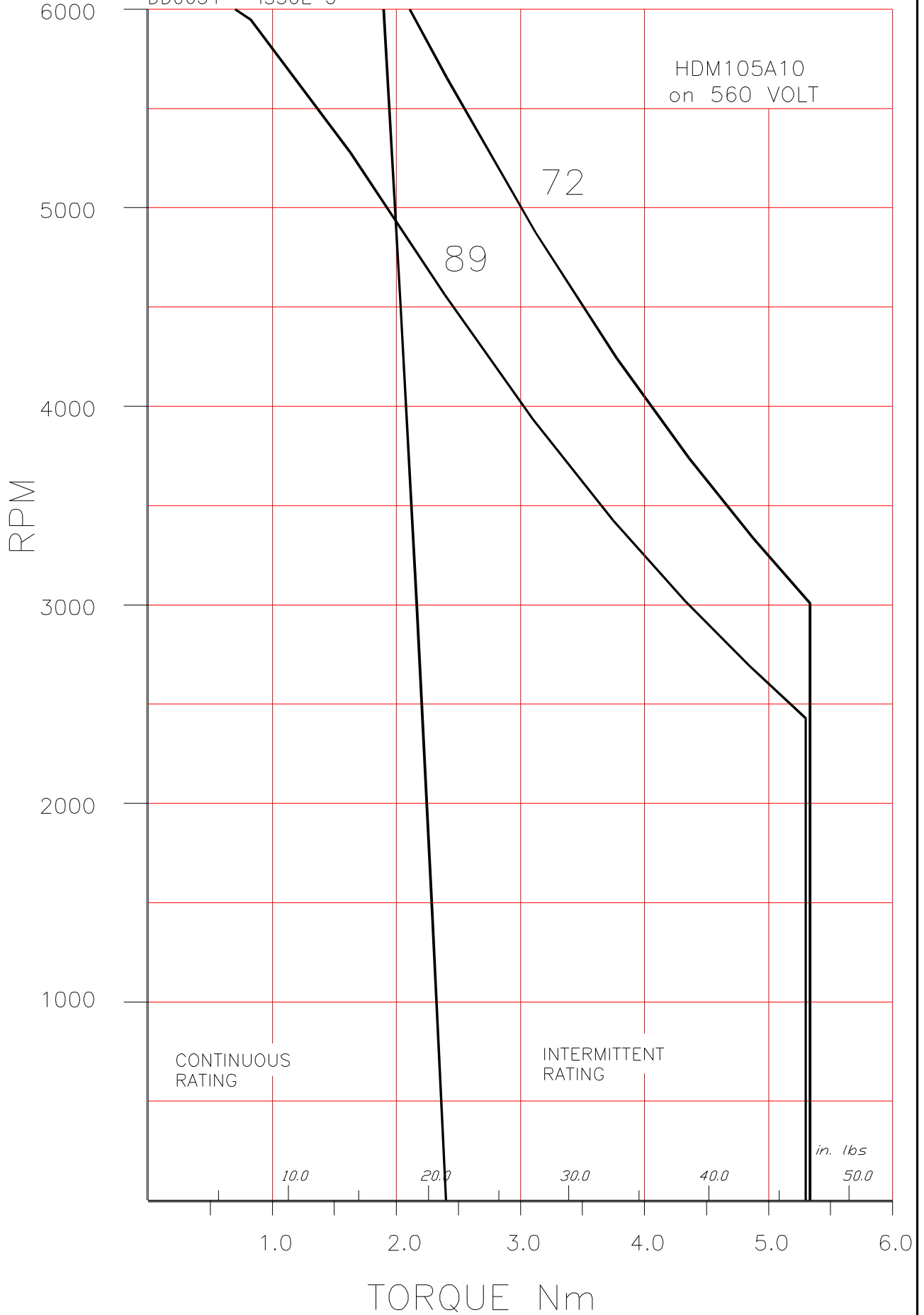

DD0678 ISSUE 3

HDM105A10
on 650 VOLT

RPM

6000

5000

4000

3000

2000

1000

CONTINUOUS
RATING

INTERMITTENT
RATING

89

72

in. lbs
50.0

10.0

20.0

30.0

40.0

1.0

2.0

3.0

4.0

5.0

6.0

TORQUE Nm

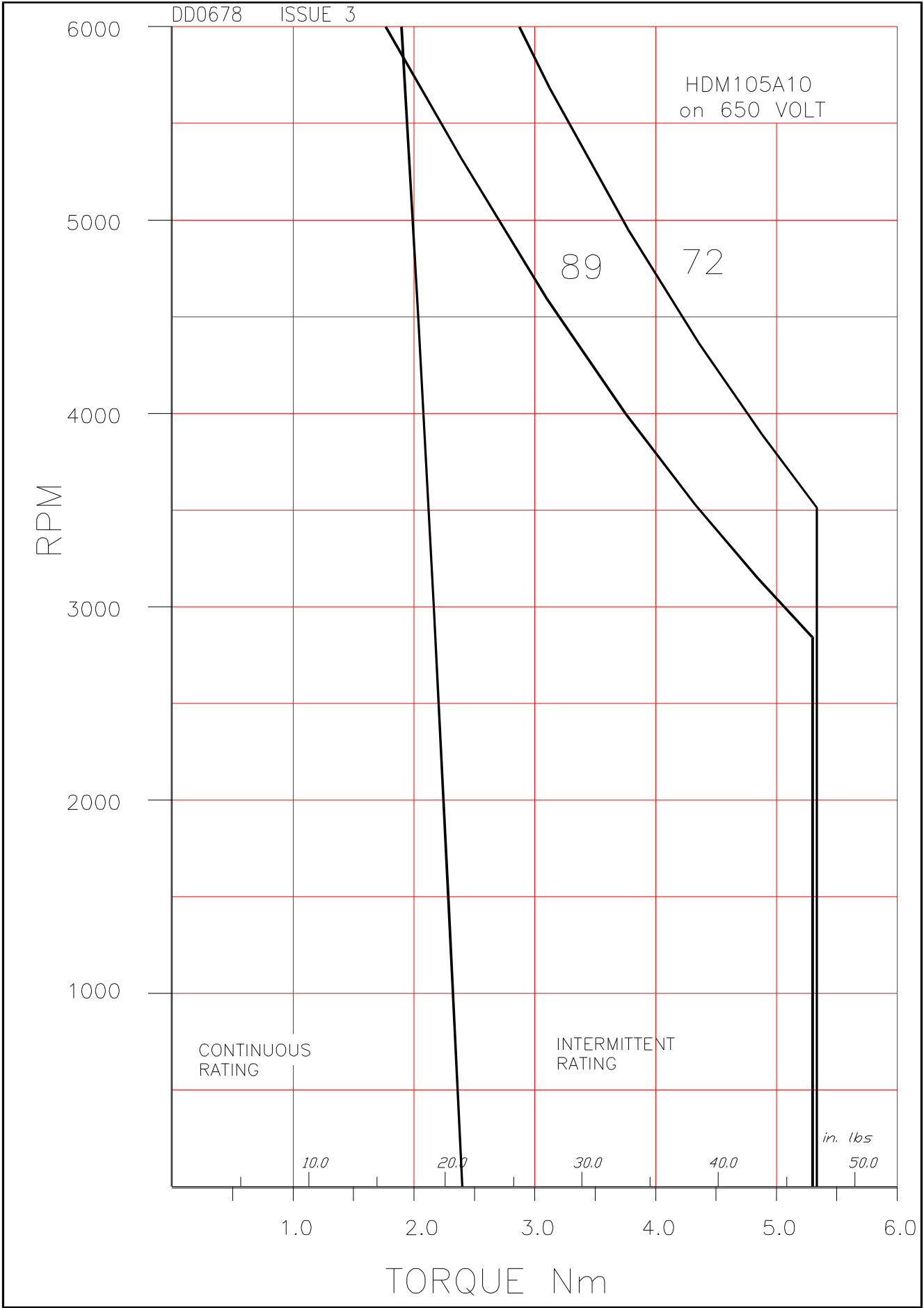

9.2 HDM105C10

HDM COMPACT SERVOMOTORS

Outline Drawing.

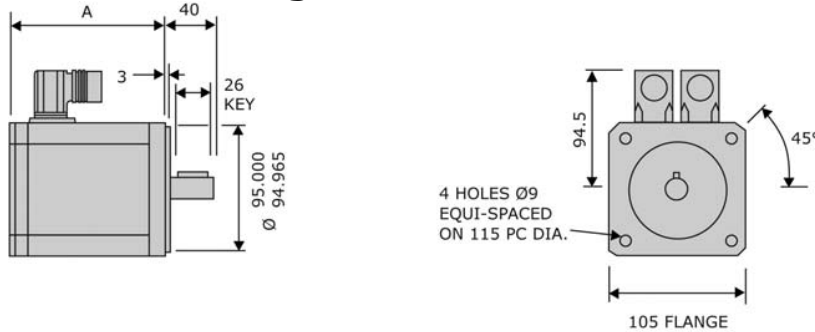

Frame	Dimension 'A'	
	without brake	with brake
HDM105A	94	139
HDM105C	120	165
HDM105E	146	191
HDM105G	172	217

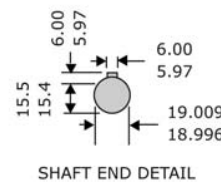

Technical Data.

Parameter	Units	HDM105 C10-39S	HDM105 C10-54S	HDM105 C10-77S
Continuous Stall Torque ¹	Nm	4.6	4.6	4.6
Continuous Stall Current ¹	A	10.1	7.3	5.1
Rated Torque ¹	Nm	4	4	4
Rated Current ¹	A	8.9	6.3	4.4
Rated Speed	rpm	3000	3000	3000
Max. Speed (300V DC link)	rpm	6000	5500	3800
Max. Speed (560V DC link) ²	rpm	-----	-----	6000
Peak Stall Torque	Nm	11	11	11
Peak Current	A	43	31	22
Resistance Line-Line ³	Ω	0.6	1.14	2.3
Inductance Line-Line ⁴	mH	1.6	3.0	6.1
Voltage Gradient No Load	V	39	54	77
Max. Motor EMF Line - Line	Volts	230	320	460
Torque Constant Kt ^{3,5}	Nm/A	0.45	0.63	0.9
Number of Poles		10	10	10
THERMAL				
Insulation Class		F	F	F
Max. Ambient Temperature	°C	40	40	40
Thermal Time Constant	minutes	35	35	35
Thermal Resistance	°C/W	0.8	0.8	0.8
MECHANICAL				
Rotor Polar Moment of Inertia	kgcm ²	2.3	2.3	2.3
Static Friction Torque	Nm	0.11	0.11	0.11
Cogging Torque	Nm	0.16	0.16	0.16
Motor Weight	kg	4.3	4.3	4.3
Motor Weight with brake fitted	kg	TBA	TBA	TBA
Continuous Stall Torque (HR/HJ) ⁶	Nm	4.3	4.3	4.3

Notes

- ¹ - Motors are tested on an aluminium heatsink with dimensions 305x305x13mm and with a temperature rise ΔT of 100K on the windings. The maximum temperature of the windings is therefore 140°C.
- ² - Where no motor speed is specified, optimal performance may not be achieved on 560V DC link.
- ³ - At 25°C.
- ⁴ - Inductance values are based on nominal current.
- ⁵ - At rated values Torque = Kt x rms current.
- ⁶ - Continuous Stall Torque (HR/HJ) is for use in comparisons with SEM's HR and HJ servomotors only.

DD0671 ISSUE 3

HDM105C10
on 150 VOLT

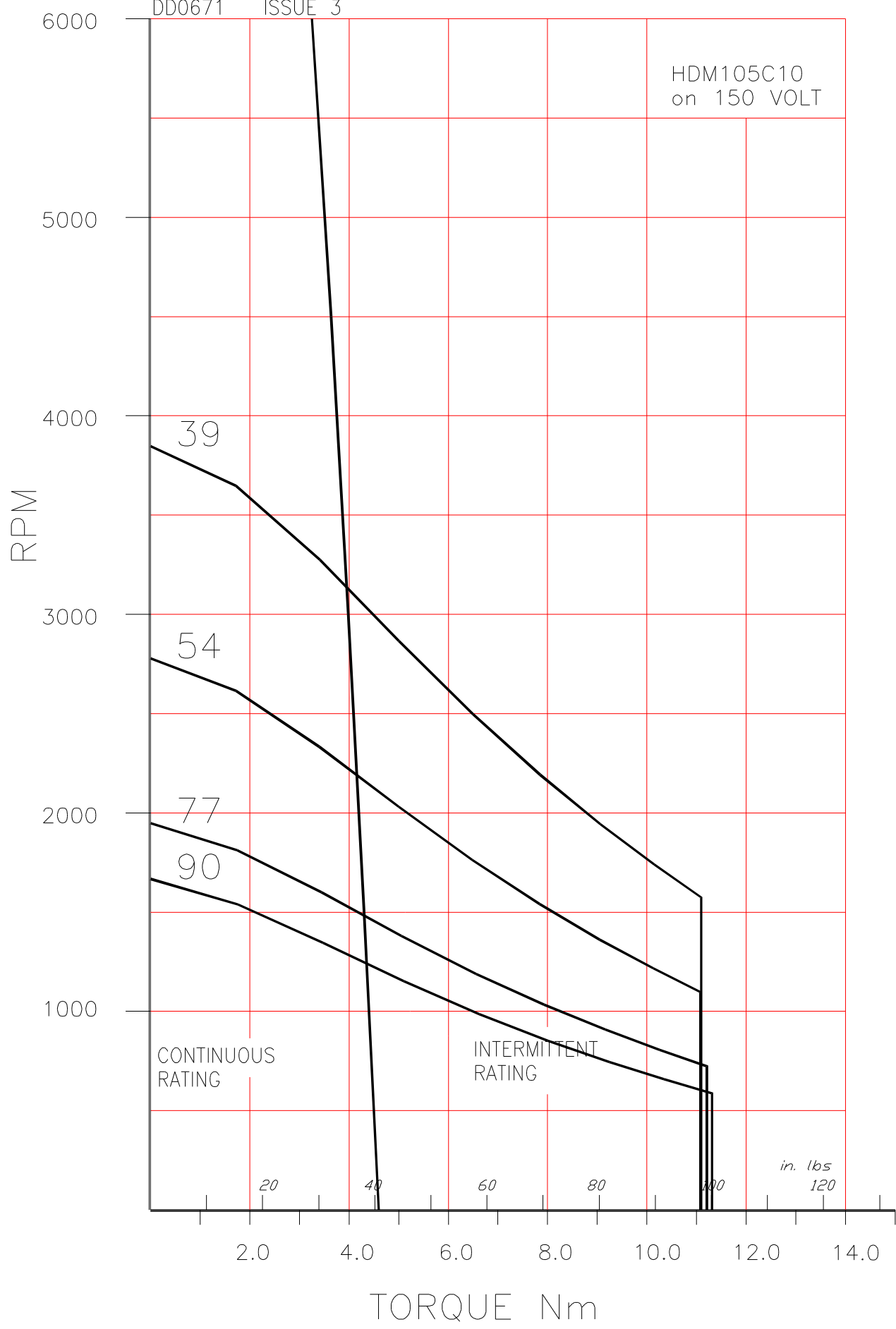

DD0631 ISSUE 3

HDM105C10
on 300 VOLT

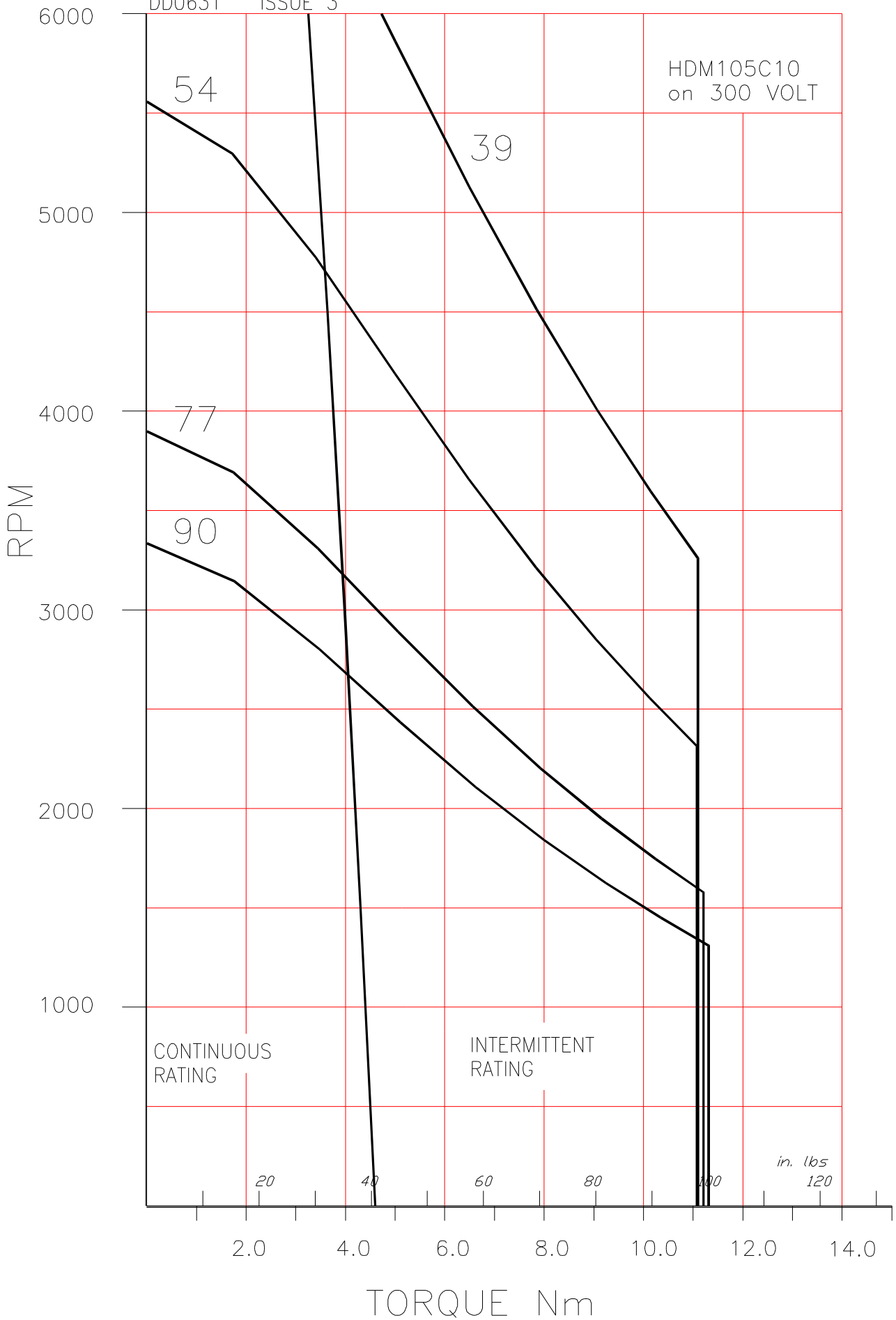

DD0635

ISSUE 3

HDM105C10
on 560 VOLT

RPM

6000

5000

4000

3000

2000

1000

CONTINUOUS
RATING

INTERMITTENT
RATING

156

90

77

20

40

60

80

100

in. lbs
120

2.0

4.0

6.0

8.0

10.0

12.0

14.0

TORQUE Nm

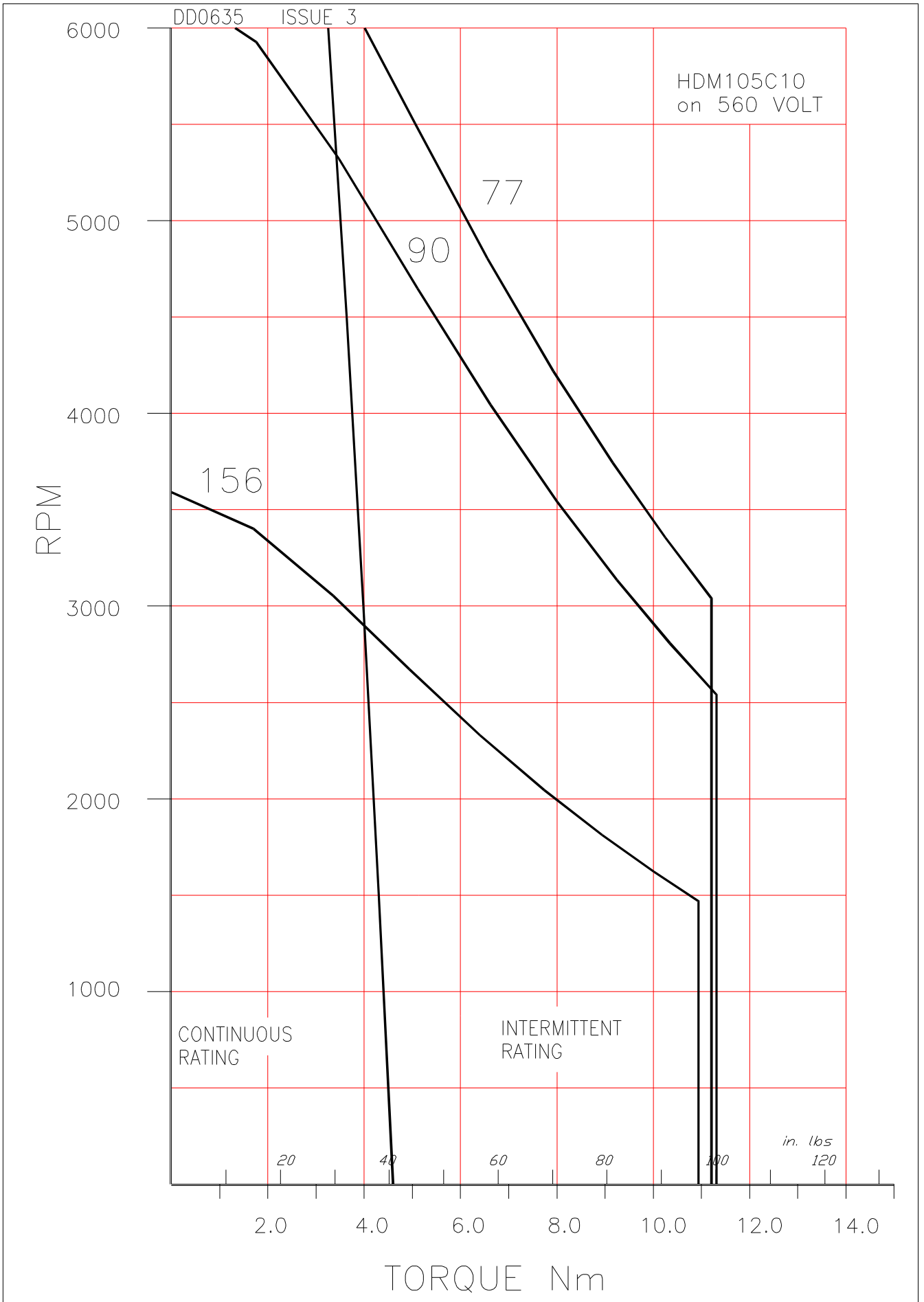

DD0679 ISSUE 3

HDM105C10
on 650 VOLT

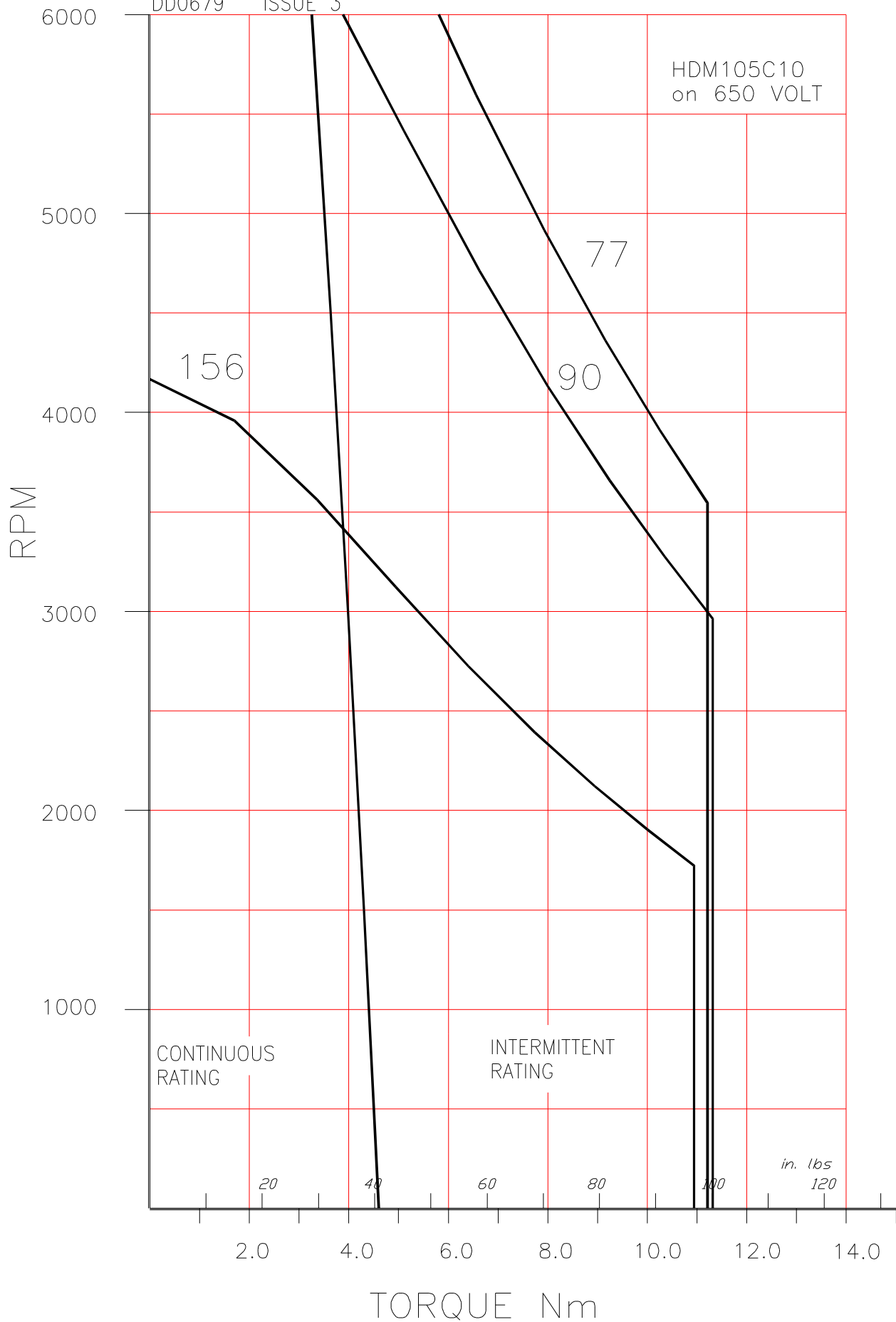

CONTINUOUS
RATING

INTERMITTENT
RATING

20

40

60

80

100

in. lbs
120

2.0

4.0

6.0

8.0

10.0

12.0

14.0

TORQUE Nm

9.3 HDM105E10

HDM COMPACT SERVOMOTORS

Outline Drawing.

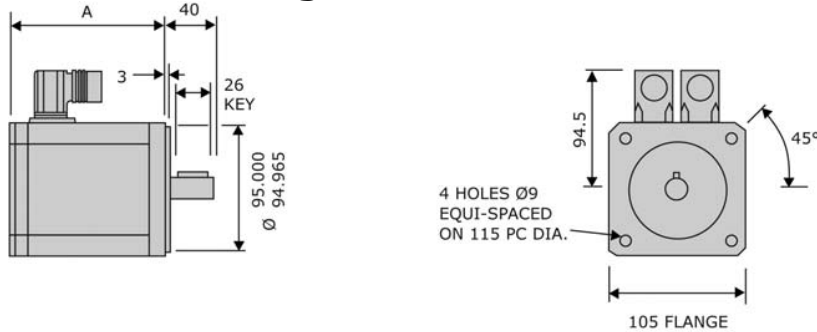

Frame	Dimension 'A'	
	without brake	with brake
HDM105A	94	139
HDM105C	120	165
HDM105E	146	191
HDM105G	172	217

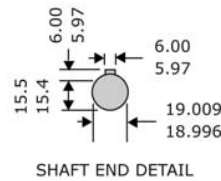

Technical Data.

Parameter	Units	HDM105E 10-51S	HDM105E 10-81S	HDM105 E10-104S
Continuous Stall Torque ¹	Nm	6.3	6.3	6.3
Continuous Stall Current ¹	A	10.6	6.7	5.2
Rated Torque ¹	Nm	5.2	5.2	5.2
Rated Current ¹	A	8.7	5.4	4.2
Rated Speed	rpm	3000	3000	3000
Max. Speed (300V DC link)	rpm	5800	3700	2800
Max. Speed (560V DC link) ²	rpm	-----	6000	5300
Peak Stall Torque	Nm	17	17	17
Peak Current	A	49	31	24
Resistance Line-Line ³	Ω	0.64	1.6	2.6
Inductance Line-Line ⁴	mH	1.8	4.4	7.0
Voltage Gradient No Load	V	51	81	104
Max. Motor EMF Line - Line	Volts	310	490	620
Torque Constant Kt ^{3,5}	Nm/A	0.6	0.96	1.23
Number of Poles		10	10	10
THERMAL				
Insulation Class		F	F	F
Max. Ambient Temperature	°C	40	40	40
Thermal Time Constant	minutes	39	39	39
Thermal Resistance	°C/W	0.7	0.7	0.7
MECHANICAL				
Rotor Polar Moment of Inertia	kgcm ²	3.2	3.2	3.2
Static Friction Torque	Nm	0.11	0.11	0.11
Cogging Torque	Nm	0.21	0.21	0.21
Motor Weight	kg	5.5	5.5	5.5
Motor Weight with brake fitted	kg	TBA	TBA	TBA
Continuous Stall Torque (HR/HJ) ⁶	Nm	5.9	5.9	5.9

Notes

- ¹ - Motors are tested on an aluminium heatsink with dimensions 305x305x13mm and with a temperature rise ΔT of 100K on the windings. The maximum temperature of the windings is therefore 140°C.
- ² - Where no motor speed is specified, optimal performance may not be achieved on 560V DC link.
- ³ - At 25°C.
- ⁴ - Inductance values are based on nominal current.
- ⁵ - At rated values Torque = Kt x rms current.
- ⁶ - Continuous Stall Torque (HR/HJ) is for use in comparisons with SEM's HR and HJ servomotors only.

HDM105E10
on 150 VOLT

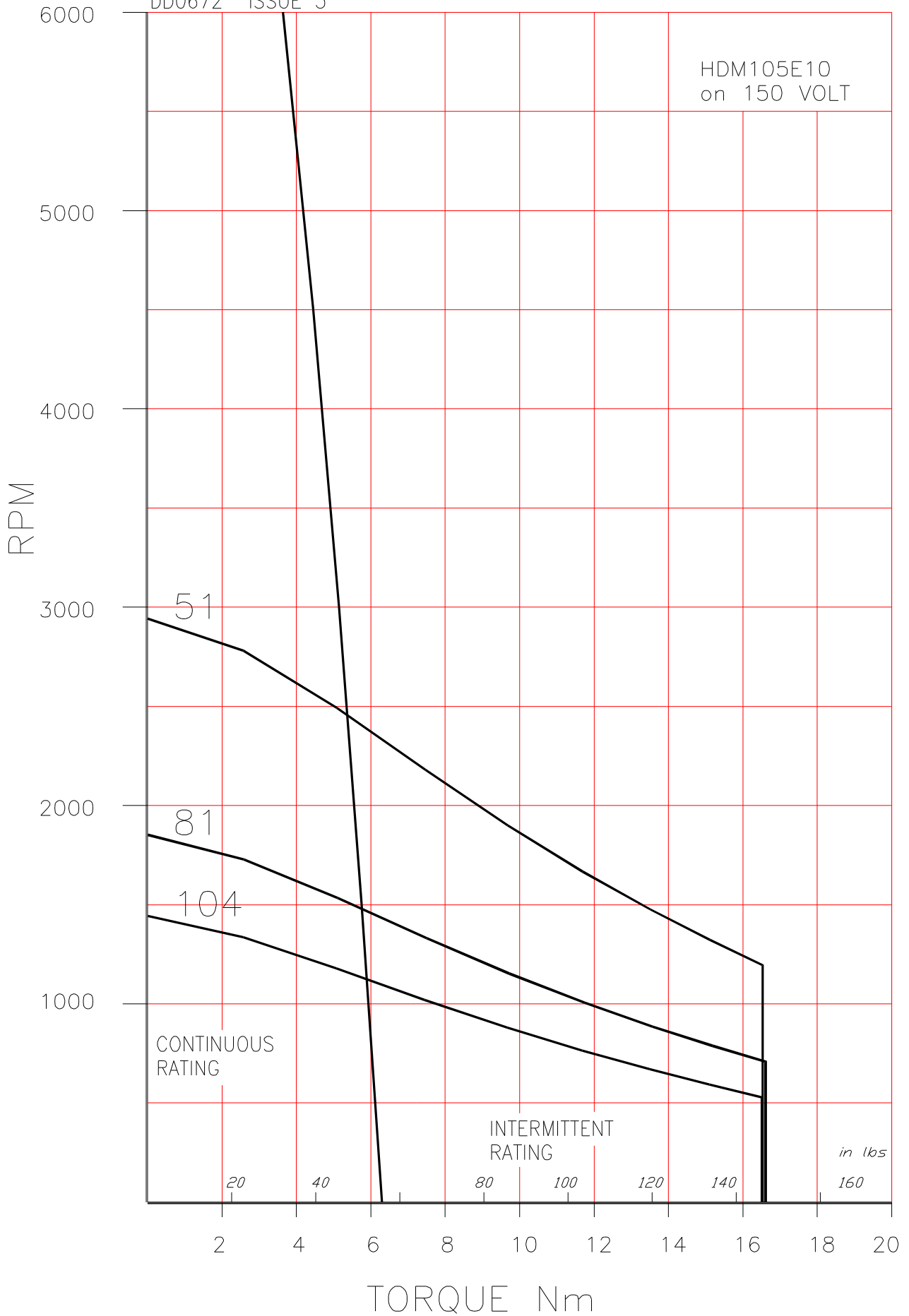

DD06332 ISSUE 3

HDM105E10
on 300 VOLT

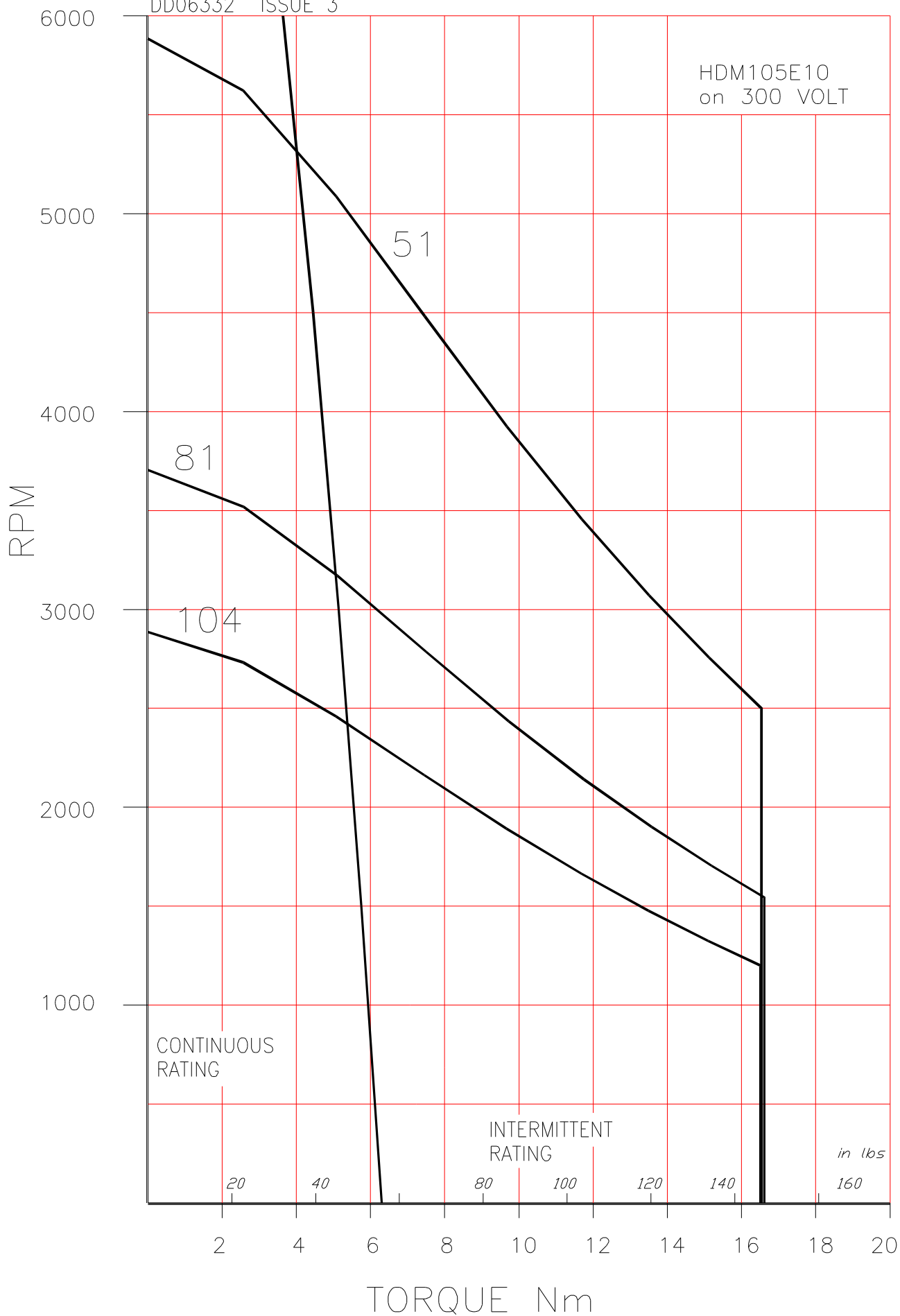

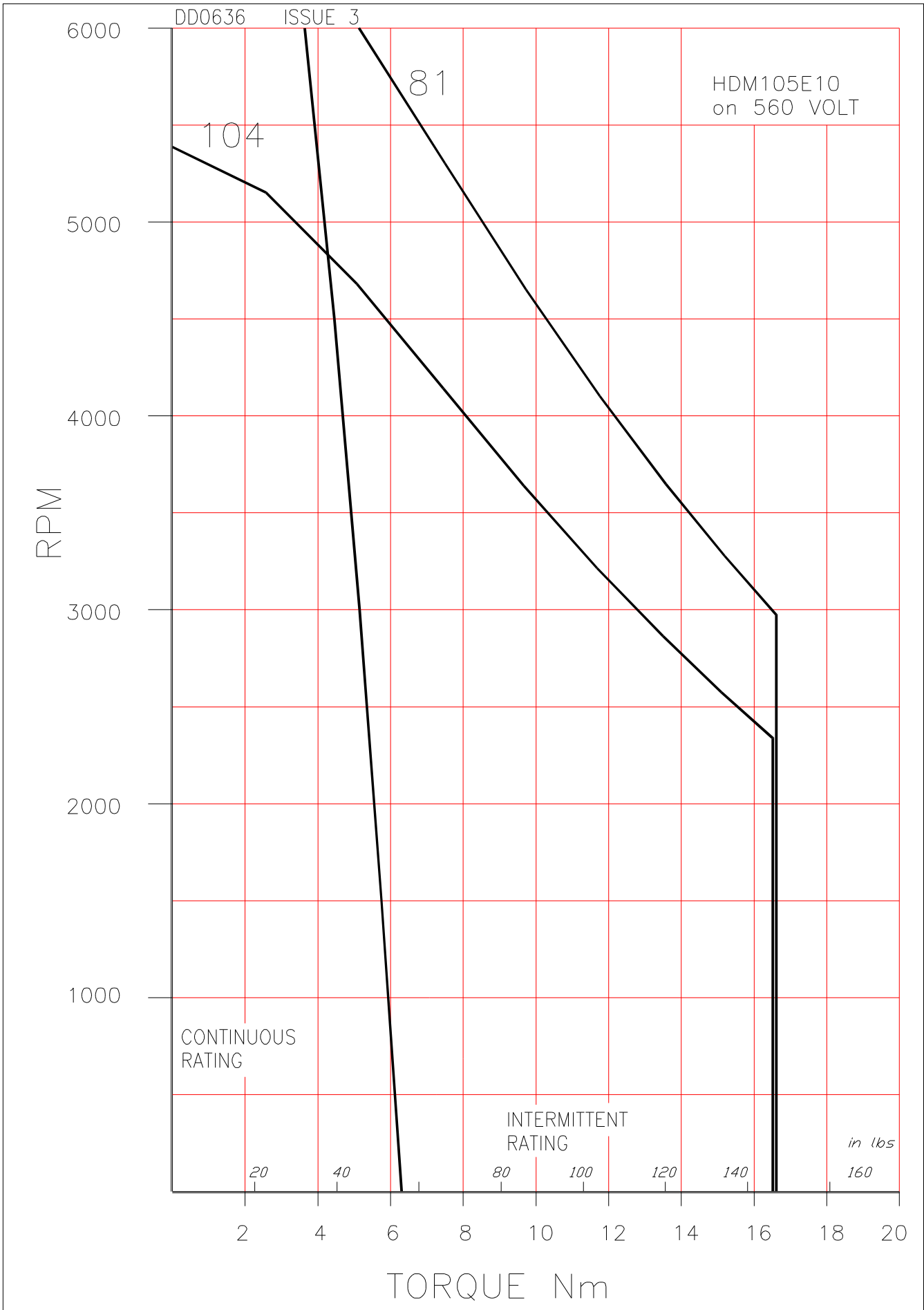

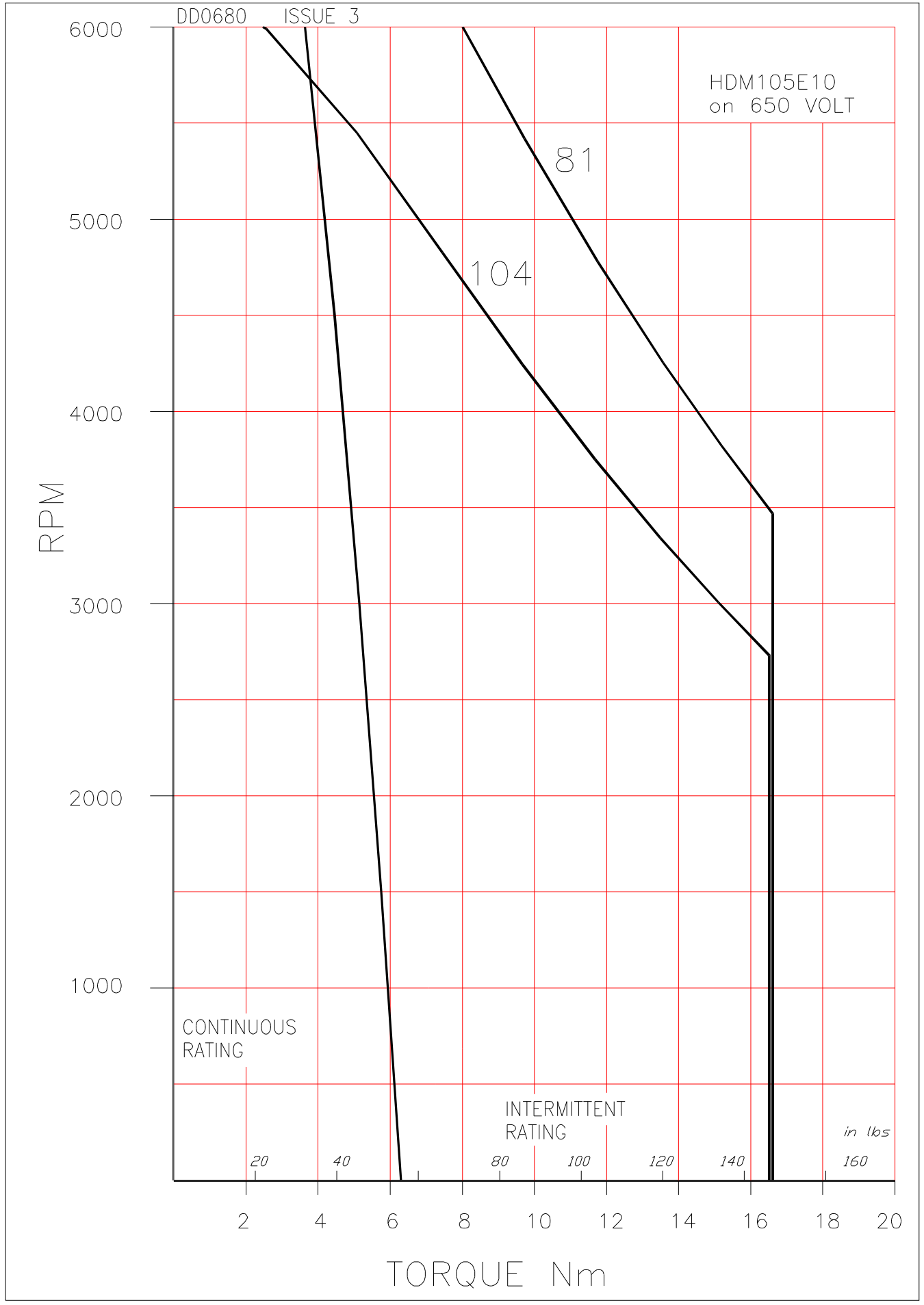

9.4 HDM105G10

HDM COMPACT SERVOMOTORS

Outline Drawing.

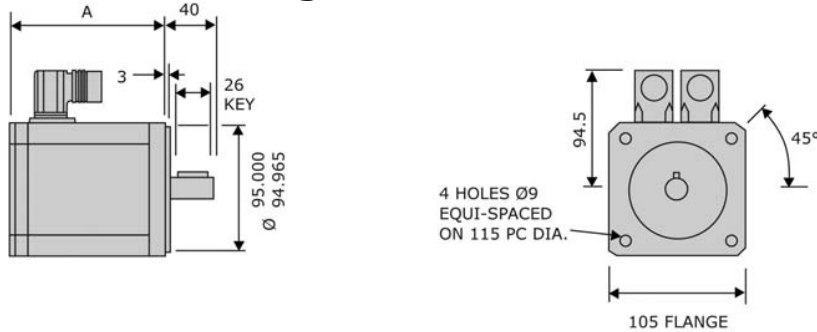

Frame	Dimension 'A'	
	without brake	with brake
HDM105A	94	139
HDM105C	120	165
HDM105E	146	191
HDM105G	172	217

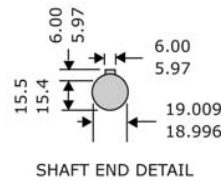

Technical Data.

Parameter	Units	HDM105 G10-69S	HDM105 G10-90S	HDM105 G10-120S
Continuous Stall Torque ¹	Nm	7.9	7.9	7.9
Continuous Stall Current ¹	A	9.8	7.5	5.6
Rated Torque ¹	Nm	5.7	5.7	5.7
Rated Current ¹	A	7	5.4	4
Rated Speed	rpm	3000	3000	3000
Max. Speed (300V DC link)	rpm	4300	3300	2500
Max. Speed (560V DC link) ²	rpm	-----	6000	4600
Peak Stall Torque	Nm	22	22	22
Peak Current	A	49	37	28
Resistance Line-Line ³	Ω	0.82	1.34	2.5
Inductance Line-Line ⁴	mH	2.3	3.9	7.0
Voltage Gradient No Load	V	69	90	120
Max. Motor EMF Line - Line	Volts	410	540	700
Torque Constant Kt ^{3,5}	Nm/A	0.81	1.05	1.41
Number of Poles		10	10	10
THERMAL				
Insulation Class		F	F	F
Max. Ambient Temperature	°C	40	40	40
Thermal Time Constant	minutes	40	40	40
Thermal Resistance	°C/W	0.58	0.58	0.58
MECHANICAL				
Rotor Polar Moment of Inertia	kgcm ²	4.1	4.1	4.1
Static Friction Torque	Nm	0.11	0.11	0.11
Cogging Torque	Nm	0.26	0.26	0.26
Motor Weight	kg	6.7	6.7	6.7
Motor Weight with brake fitted	kg	TBA	TBA	TBA
Continuous Stall Torque (HR/HJ) ⁶	Nm	7.5	7.5	7.5

Notes

- ¹ - Motors are tested on an aluminium heatsink with dimensions 305x305x13mm and with a temperature rise ΔT of 100K on the windings. The maximum temperature of the windings is therefore 140°C.
- ² - Where no motor speed is specified, optimal performance may not be achieved on 560V DC link.
- ³ - At 25°C.
- ⁴ - Inductance values are based on nominal current.
- ⁵ - At rated values Torque = Kt x rms current.
- ⁶ - Continuous Stall Torque (HR/HJ) is for use in comparisons with SEM's HR and HJ servomotors only.

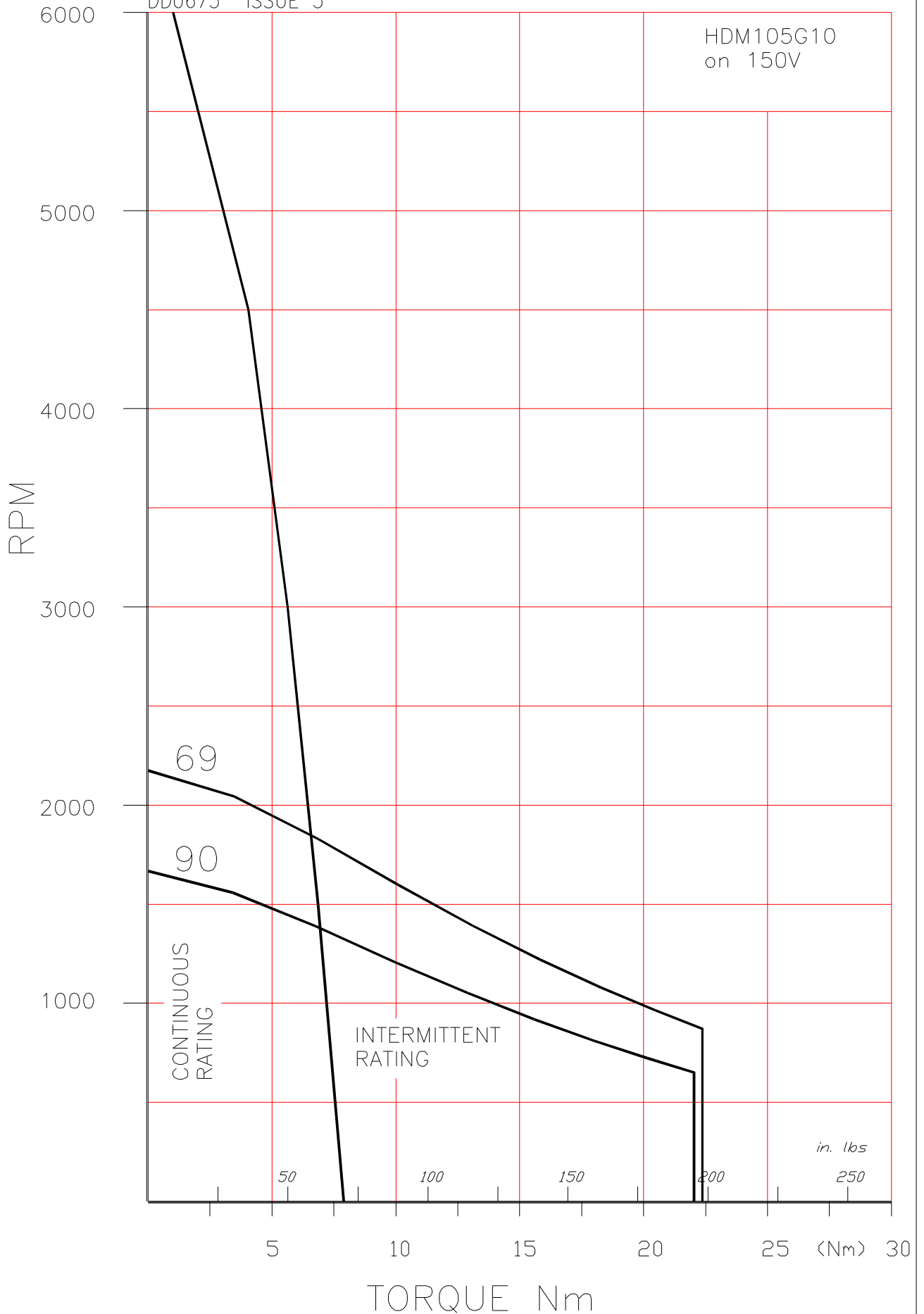

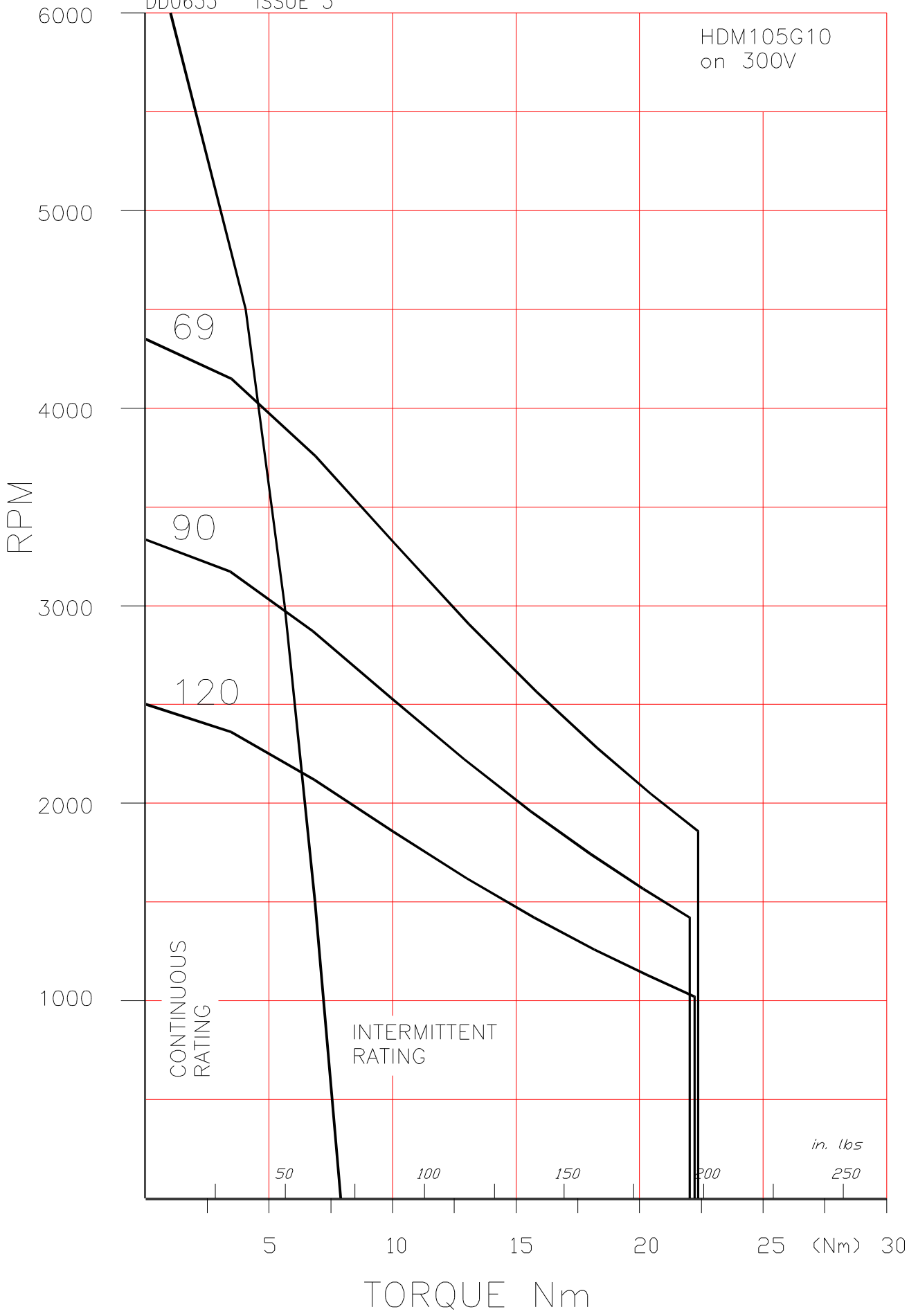

50

100

150

200

in. lbs

250

TORQUE Nm

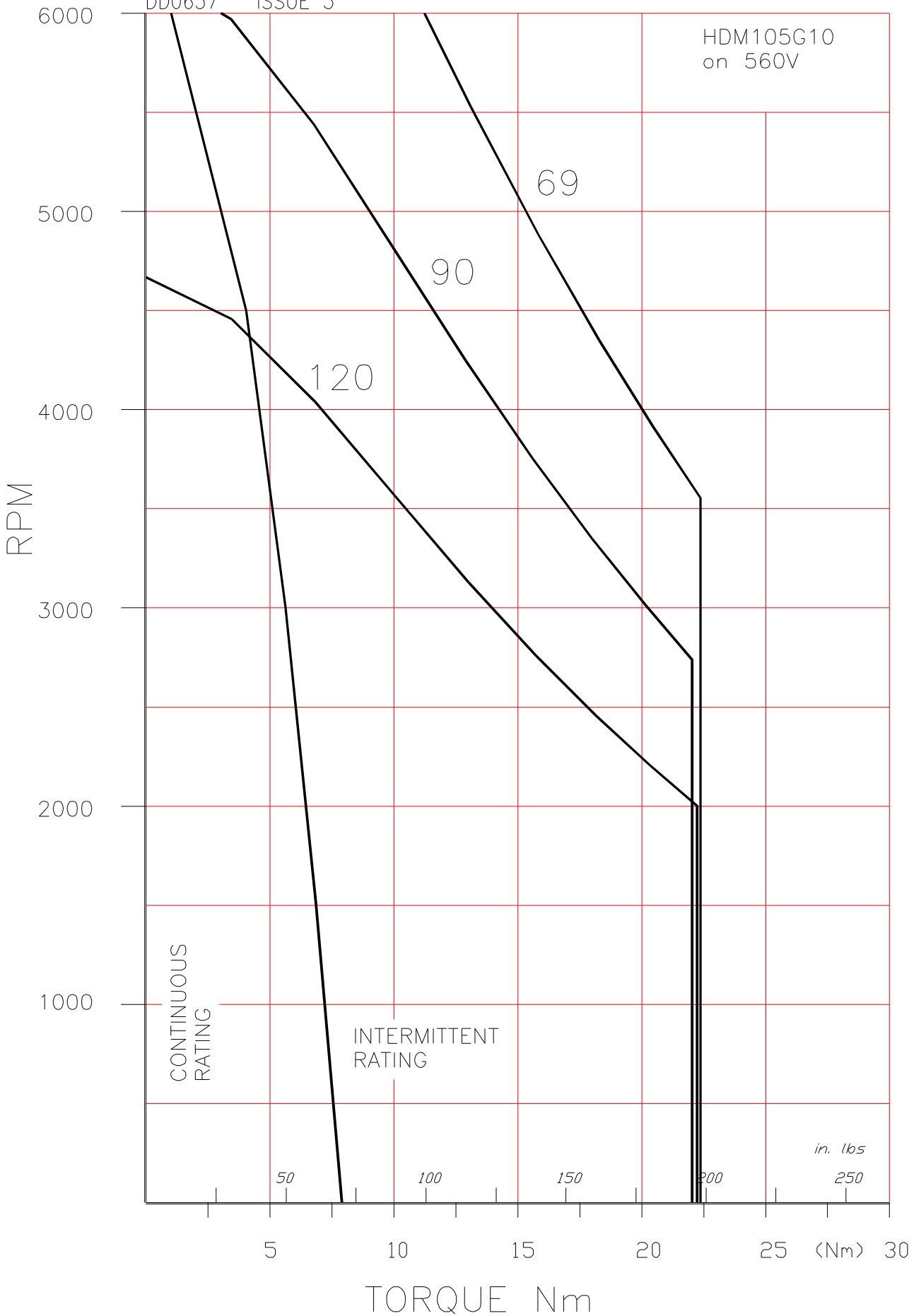

CONTINUOUS
RATING

INTERMITTENT
RATING

in. lbs

50

100

150

200

250

TORQUE Nm

(Nm)

DD0681 ISSUE 3

HDM105G10
on 650V

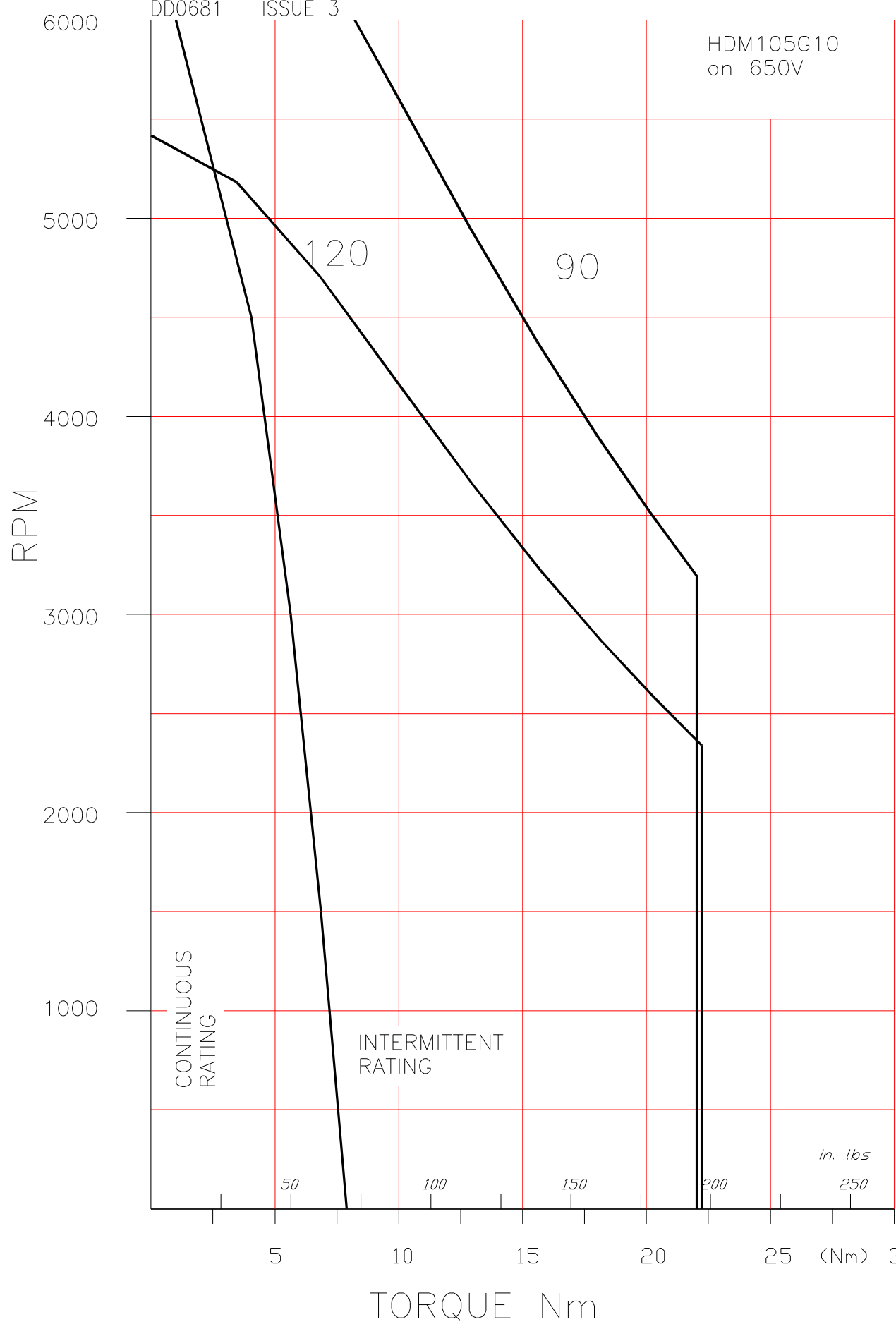

HDM105 PERMITTED RADIAL SHAFT LOADINGS

(Axial loading maybe considered separately - refer to next page)

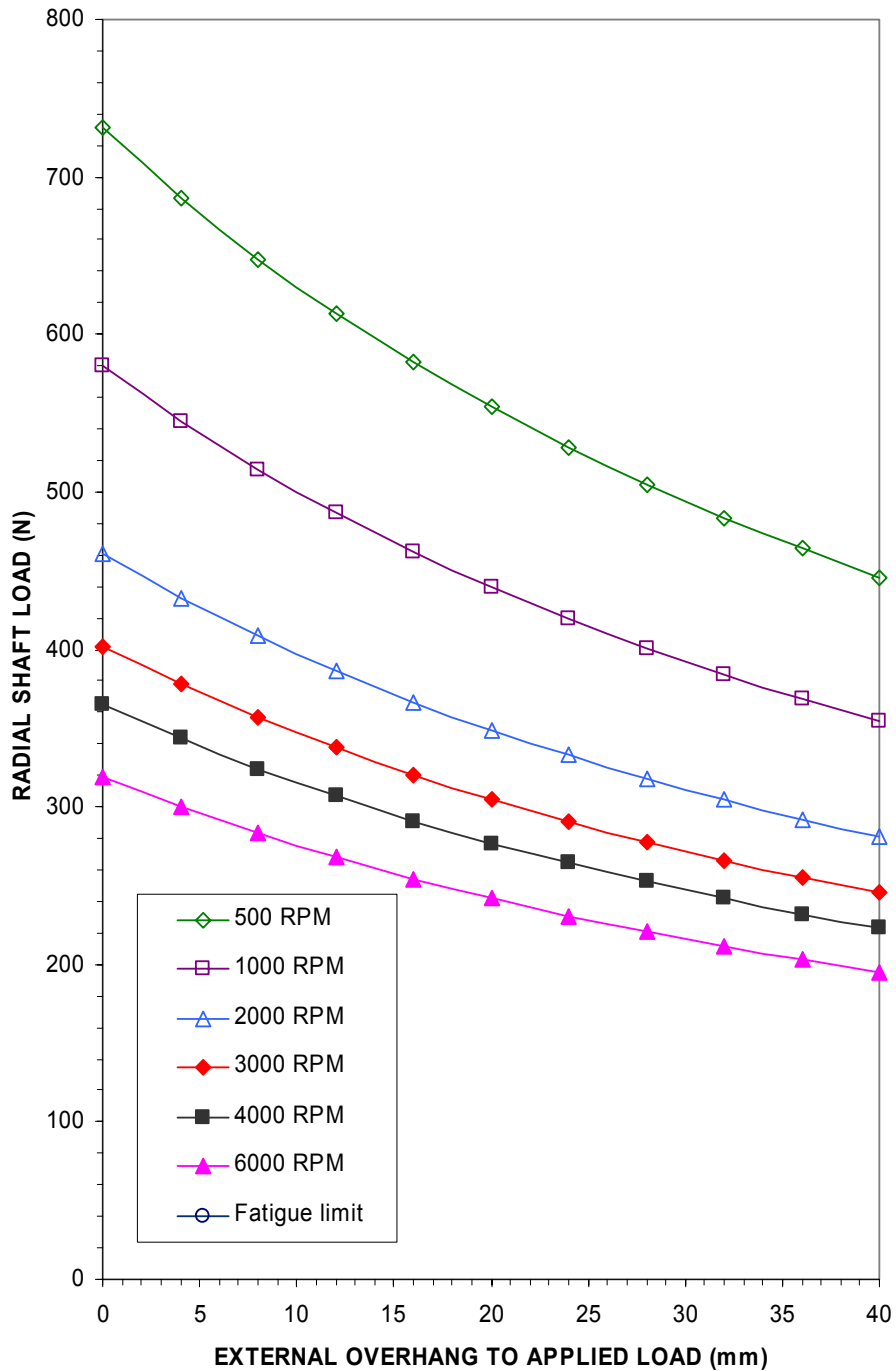

Shaft Loading Information for SEM Standard Servomotors

General notes:-

1 All loadings are based upon An L10 bearing life expectancy of 30,000 hours.

2 Separate graphs are usually supplied to indicate maximum axial loads which are applicable. However, for motors with locked drive end bearings, a graph is used to illustrate the maximum allowed radial shaft loadings together with a simplified calculation to provide a compensated figure for when radial and axial loadings are to be applied in combination.

3 It may occur, in certain circumstances, that loading outside the scope of the published information is deemed necessary. In these cases it is desirable that SEM Ltd should be consulted and all relevant information made available, in order that due consideration can be given to finding a satisfactory solution.

4 Should motors be required to operate under abnormal conditions, such as excessive vibration or shock, this should also be referred to SEM Ltd as noted above.

HDM105 PERMITTED AXIAL LOAD

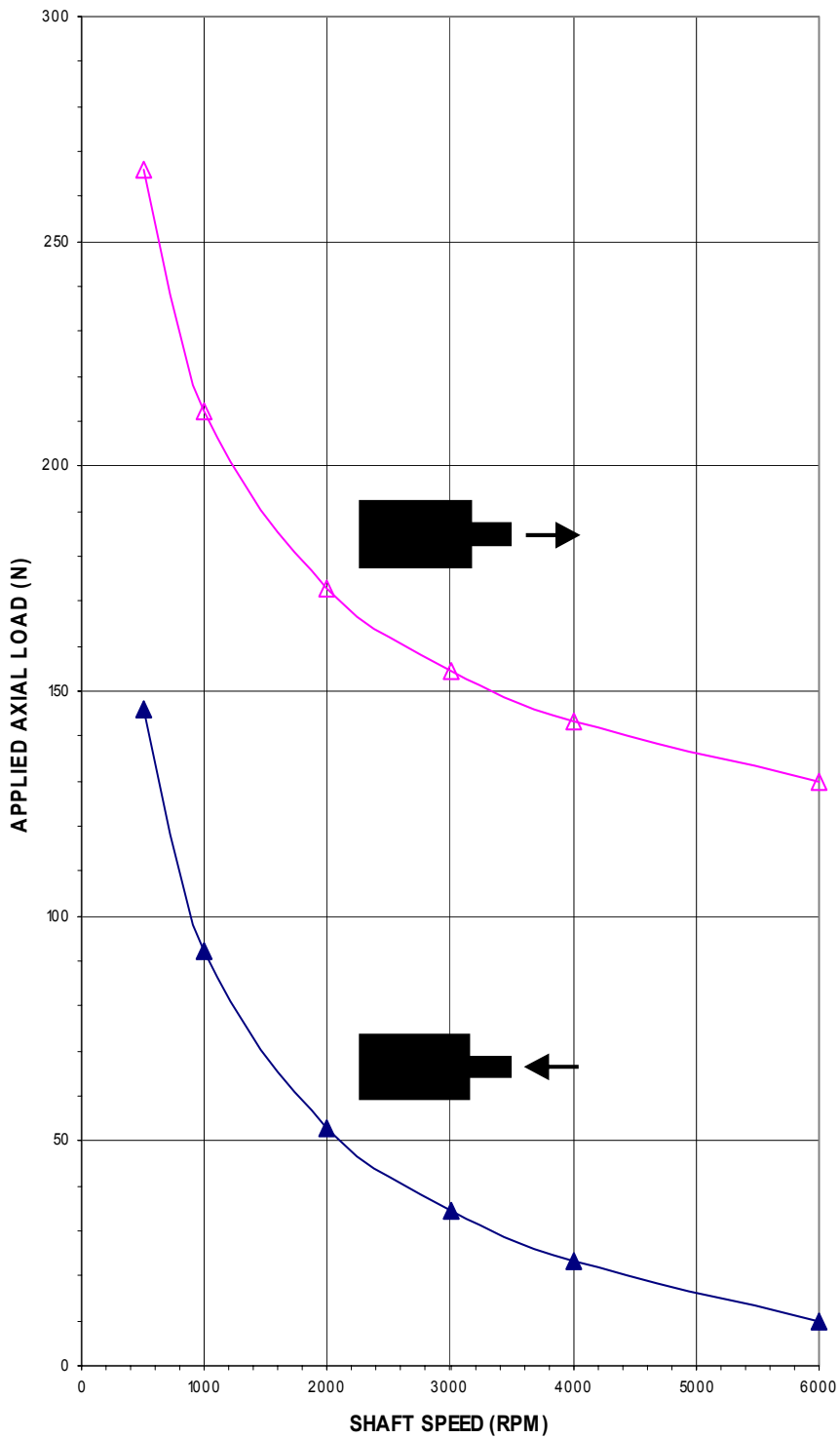

Shaft Loading Information for SEM Standard Servomotors

General notes:-

- 1 All loadings are based upon An L10 bearing life expectancy of 30,000 hours.
- 2 Separate graphs are usually supplied to indicate maximum axial loads which are applicable. However, for motors with locked drive end bearings, a graph is used to illustrate the maximum allowed radial shaft loadings together with a simplified calculation to provide a compensated figure for when radial and axial loadings are to be applied in combination.
- 3 It may occur, in certain circumstances, that loading outside the scope of the published information is deemed necessary. In these cases it is desirable that SEM Ltd should be consulted and all relevant information made available, in order that due consideration can be given to finding a satisfactory solution.
- 4 Should motors be required to operate under abnormal conditions, such as excessive vibration or shock, this should also be referred to SEM Ltd as noted above.

FIRST ANGLE PROJECTION

MOTOR CONNECTOR :- INTERCONNECTOR SIZE 1, 6 PIN
 FEEDBACK CONNECTOR :- INTERCONNECTOR SIZE 1, 12 PIN, 20' OFFSET

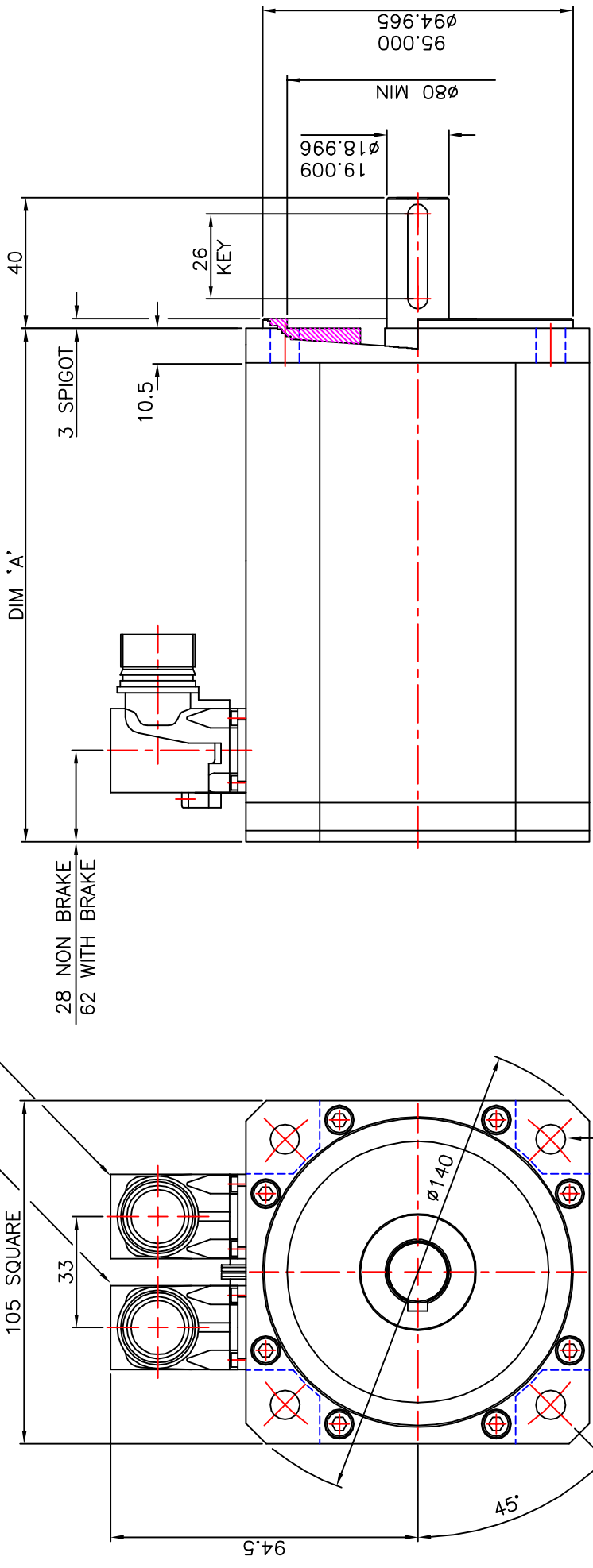

4-HOLES $\phi 9$ EQUI-SPACED ON A 115 PCD

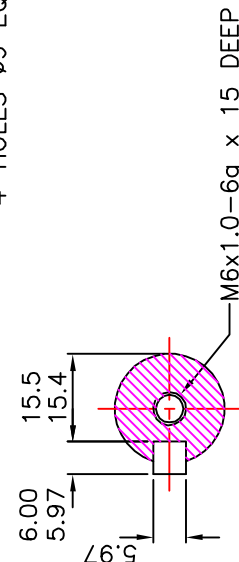

SHAFT SECTION
 DETAIL

FRAME	NO BRAKE	WITH BRAKE
105A	94	139
105C	120	165
105E	146	191
105G	172	217

4 10AUG04 KEYWAY NOW ENCLOSED TO MR3176
 5 07SEP05 R35i & IEC72 RECESS ADDED MR3554

TITLE : OUTLINE HDM105 STD METRIC - RESOLVER & R35i

DRAWING NO.	664-7-06349	SCALE	3:4
		ISSUE No.	5
		DR.	GFD
		DATE	07MAY03
			A06349E1



ALL DIMENSIONS IN MILLIMETRES
 TOLERANCES UNLESS ANG: $\pm 0.5^\circ$
 OTHERWISE STATED DIM: $\pm 0.25\text{mm}$

HDM105 - OPTIONS (metric series)

Code	Description	Notes
WAVEFORM (WINDING)		
Y00-A*	Waveform	Sinusoidal waveform
FEEDBACK DEVICES		
F00-C*	Resolver (F00 setting)	2 Pole Resolver type 15-B with F00 setting
F66-A	No Feedback device fitted	
FITTED ENCODERS		
E28-A	Incremental Encoder	Renco R35i, 2048ppr
E30-A	Incremental Encoder	Renco R35i, 4098ppr
E31-A	Incremental Encoder	Renco R35i, 8192ppr
E15-C	Encoder	Heidenhain ERN1387 series, 2048ppr.
E22-B	Encoder, singleturn, Optical	Heidenhain ECN1313 series, 2048ppr with EnDat Interface.
E16-A	Encoder, multiturn, Optical	Heidenhain EQN1325 series, 2048ppr with EnDat Interface.
E33-A	Encoder, singleturn, Inductive	Heidhenhain ECI1319 series, 32ppr with EnDat Interface
E34-A	Encoder, multiturn, Inductive	Heidhenhain ECI1331 series, 32ppr with EnDat Interface
MECHANICAL INTERFACE		
M00-P*	Flange	105 x 105 mm square flange. Spigot Ø 95mm. Fixing 4 x Ø 9 mm holes on 115 mm PCD
R01-A	Close tolerance interface	Flange & shaft to IEC72-P (precision)
S00-I*	Shaft	Ø 19mm x 40mm long
K10-A*	Keyway	6 x 6 x 32 mm long, keyway with key enclosed type, also with half key supplied 6 x 3 x 32mm long
K99-A	No Keyway	Plain shaft
D01-G*	Shaft end threaded hole	M x 18mm deep
D99-A	No Shaft end threaded hole	
BRAKES		
B00-J	24Vdc Brake	10Nm. Torque, Spring Applied
ELECTRICAL TERMINATIONS		
C47-A*	Motor & feedback connector	Interconnectron size 1 power connector (6 pin) and size 1 feedback receptacle (12 pin) facing DE (resolver motors)
C48-A	Motor & feedback connector	Interconnectron size 1 power connector (6 pin) and size 1 feedback receptacle (17 pin) facing DE (encoder motors)
C67-A	Motor plug	Interconnectron straight plug (6 pin) to suit option C47 and C48
C68-A	Feedback plug	Interconnectron straight plug (12 pin) to suit option C47
C69-A	Feedback plug	Interconnectron straight plug (17 pin) to suit option C48
THERMAL PROTECTION		
P17-A*	KTY84-130 Thermal Sensor	
P18-A	No thermal overload	Thermal protection not fitted
ENCLOSURE PROTECTION		
W00-B*	IP64/65 enclosure	Nitrile shaft seal for IP64/65 protection (factory fitted)
W02-B	IP64/65 enclosure	Nitrile shaft seal for IP64/65 protection (supplied loose)
W01-I	IP64/65 enclosure	Viton shaft seal for IP64/65 protection (factory fitted)
W03-I	IP64/65 enclosure	Viton shaft seal for IP64/65 protection (supplied loose)
W99-A	No Shaft Seal Fitted	

*Standard feature

HDM142A10

HDM142C10

HDM142E10

HDM142J10

HDM142

10

10.1 HDM142A10

HDM COMPACT SERVOMOTORS

Outline Drawing.

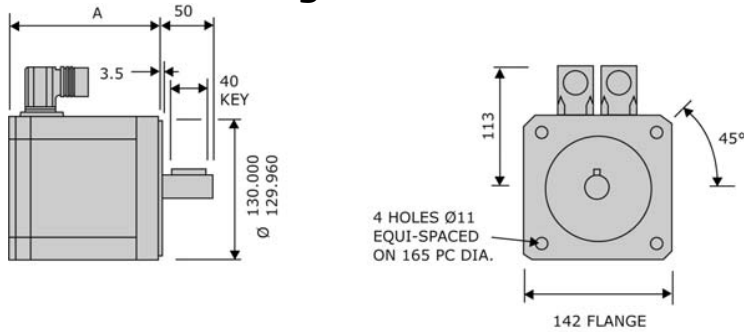

Frame	Dimension 'A'	
	without brake	with brake
HDM142A	112	172
HDM142C	132	192
HDM142E	157	217
HDM142J	207	267

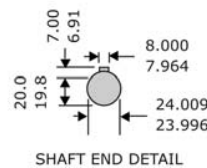

Technical Data.

Parameter	Units	HDM142 A10-54S	HDM142 A10-75S	HDM142 A10-107S
Continuous Stall Torque 1	Nm	9.1	9.1	9.1
Continuous Stall Current 1	A	14	10.4	7.3
Rated Torque ¹	Nm	8	8	8
Rated Current ¹	A	12.7	9.2	6.3
Rated Speed	rpm	3000	3000	3000
Max. Speed (300V DC link)	rpm	5000	4000	2800
Max. Speed (560V DC link) ²	rpm	-----	5000	5000
Peak Stall Torque	Nm	20	20	20
Peak Current	A	56	41	28
Resistance Line-Line ³	Ω	0.55	1.06	2.1
Inductance Line-Line ⁴	mH	2.7	5.1	10.5
Voltage Gradient No Load	V	54	75	107
Max. Motor EMF Line - Line	Volts	270	380	540
Torque Constant Kt ^{3,5}	Nm/A	0.63	0.87	1.26
Number of Poles		10	10	10
THERMAL				
Insulation Class		F	F	F
Max. Ambient Temperature	°C	40	40	40
Thermal Time Constant	minutes	30	30	30
Thermal Resistance	°C/W	0.42	0.42	0.42
MECHANICAL				
Rotor Polar Moment of Inertia	kgcm ²	6.6	6.6	6.6
Static Friction Torque	Nm	0.12	0.12	0.12
Cogging Torque	Nm	0.2	0.2	0.2
Motor Weight	kg	6.2	6.2	6.2
Motor Weight with brake fitted	kg	TBA	TBA	TBA
Continuous Stall Torque (HR/HJ) ⁶	Nm	8.1	8.1	8.1

Notes

- ¹ - Motors are tested on an aluminium heatsink with dimensions 457x457x13mm and with a temperature rise ΔT of 100K on the windings. The maximum temperature of the windings is therefore 140°C.
- ² - Where no motor speed is specified, optimal performance may not be achieved on 560V DC link.
- ³ - At 25°C.
- ⁴ - Inductance values are based on nominal current.
- ⁵ - At rated values Torque = Kt x rms current.
- ⁶ - Continuous Stall Torque (HR/HJ) is for use in comparisons with SEM's HR and HJ servomotors only.

PROVISIONAL

HDM142A10
on 150VDC
(5kHz PWM)

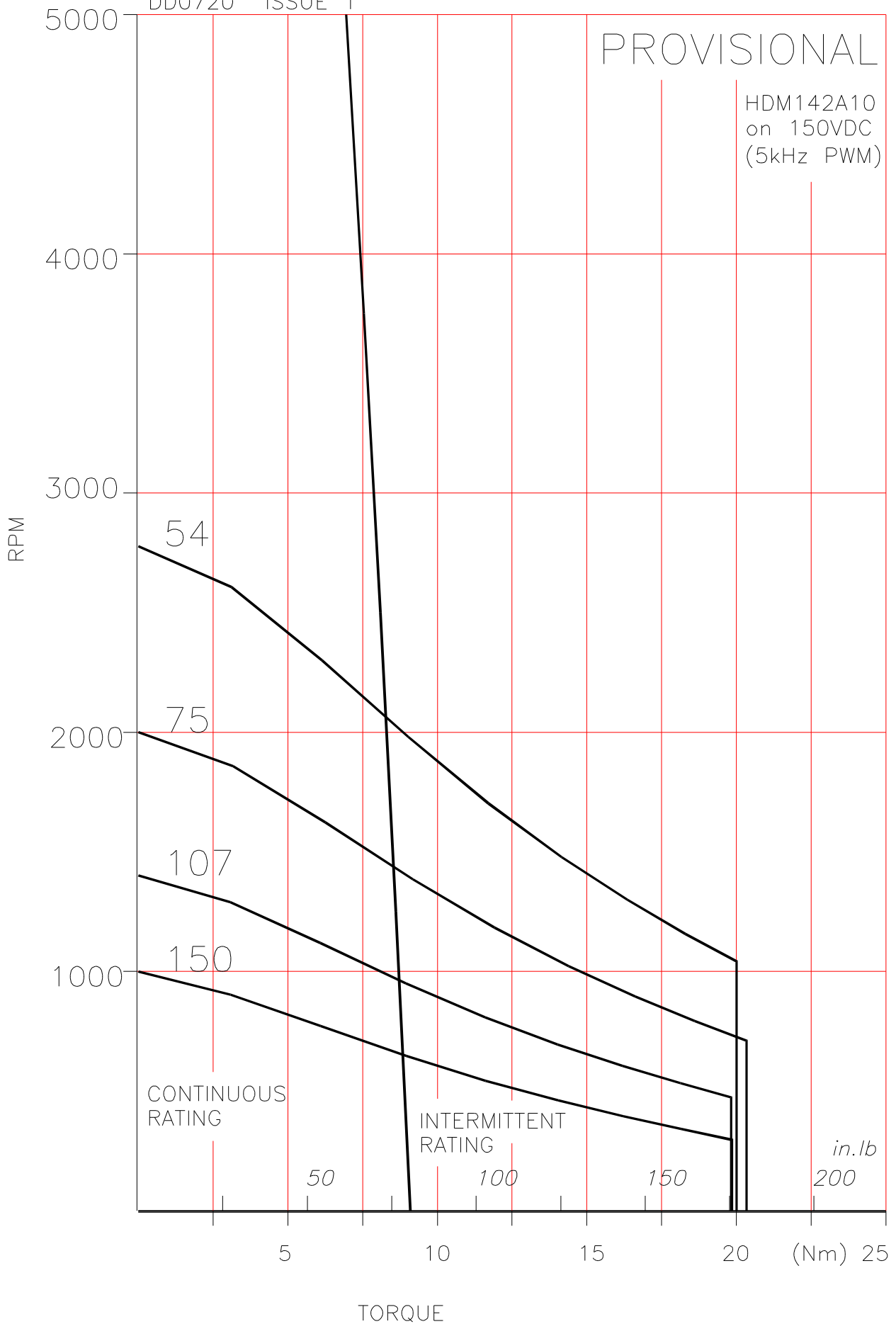

DD0728 ISSUE 1

PROVISIONAL

HDM142A10
on 300VDC
(5kHz PWM)

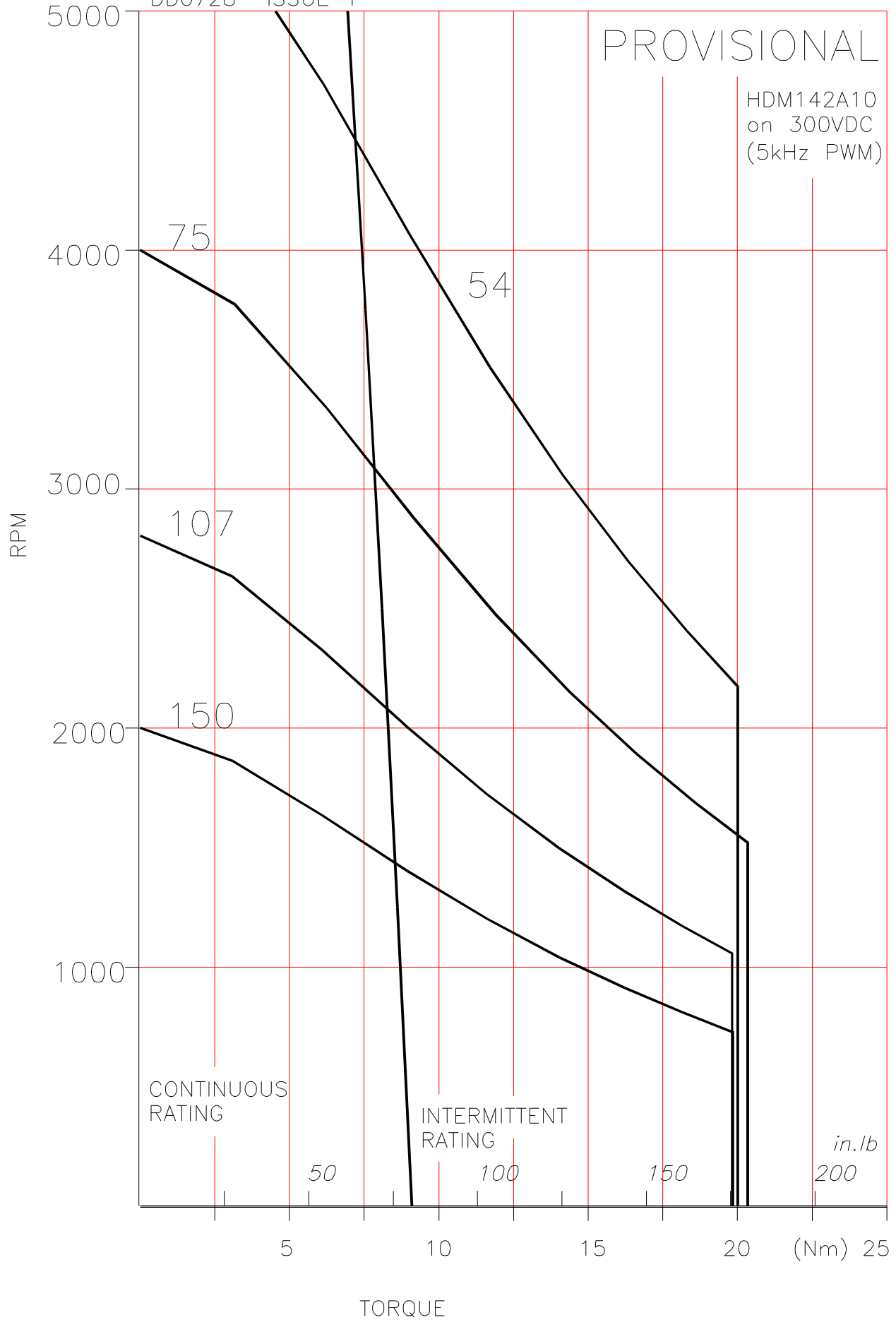

DD0732 ISSUE 1

PROVISIONAL

HDM142A10
on 560VDC
(5kHz PWM)

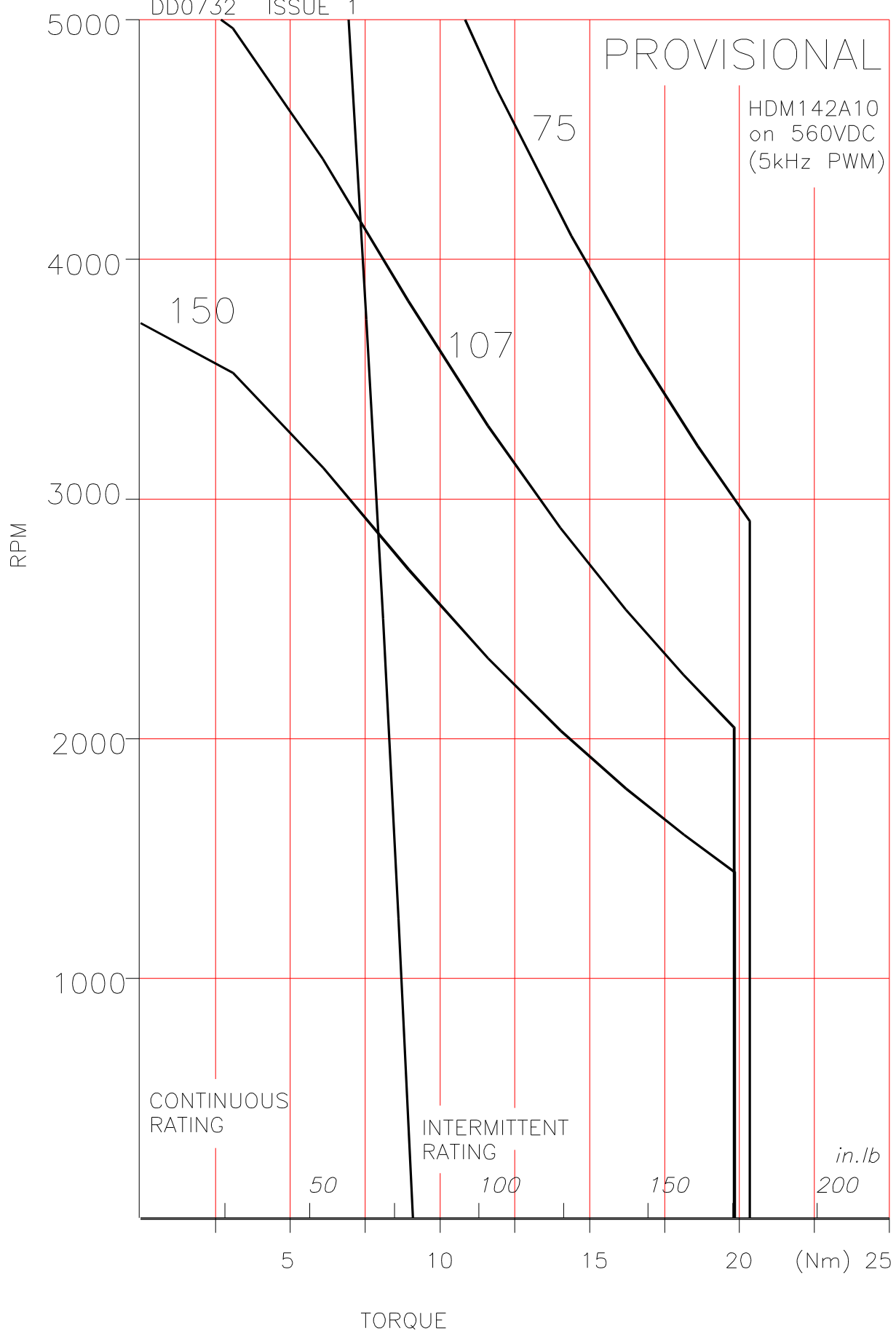

DD0736 ISSUE 1

PROVISIONAL

HDM142A10
on 650VDC
(5kHz PWM)

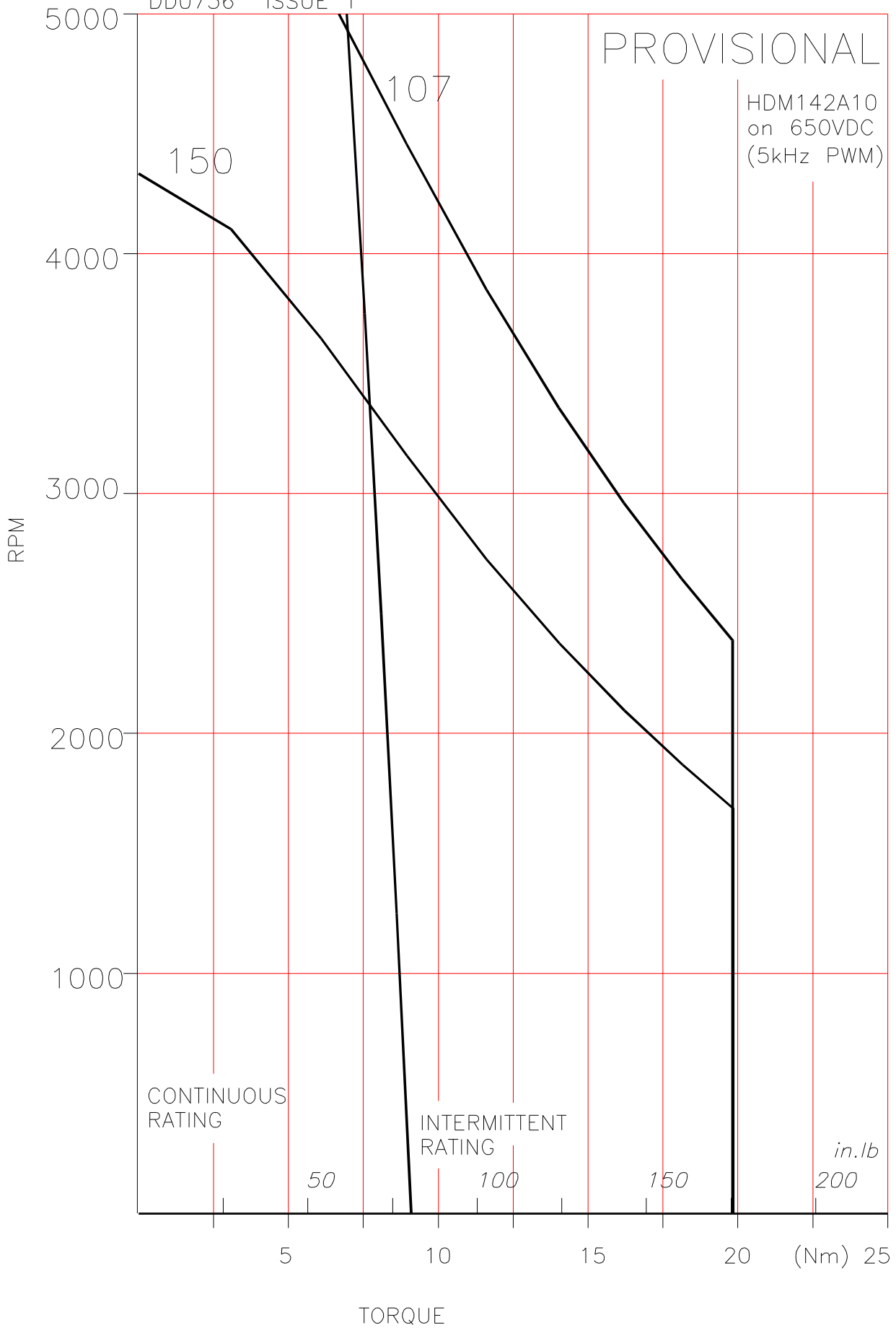

CONTINUOUS RATING

INTERMITTENT RATING

in.lb
200

50

100

150

5

10

15

20

(Nm) 25

TORQUE

10.2 HDM142C10

HDM COMPACT SERVOMOTORS

Outline Drawing.

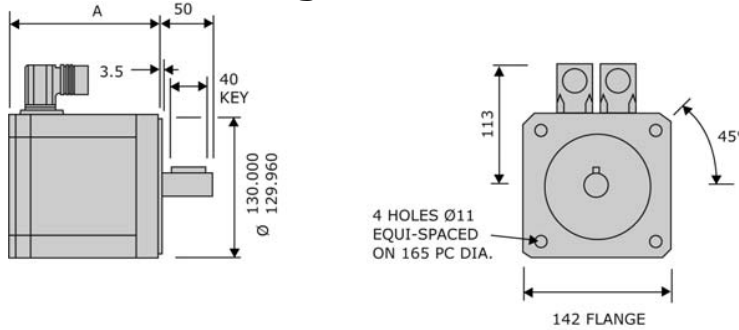

Frame	Dimension 'A'	
	without brake	with brake
HDM142A	112	172
HDM142C	132	192
HDM142E	157	217
HDM142J	207	267

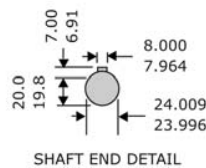

Technical Data.

Parameter	Units	HDM142 C10-76S	HDM142 C10-107S	HDM142 C10-152S
Continuous Stall Torque 1	Nm	13	13	13
Continuous Stall Current 1	A	15	10.4	7.3
Rated Torque ¹	Nm	11	11	11
Rated Current ¹	A	12.2	8.7	6.1
Rated Speed	rpm	3000	3000	3000
Max. Speed (300V DC link)	rpm	3900	2800	2000
Max. Speed (560V DC link) ²	rpm	5000	5000	3700
Peak Stall Torque	Nm	34	34	34
Peak Current	A	68	48	34
Resistance Line-Line ³	Ω	0.52	1.03	2
Inductance Line-Line ⁴	mH	2.9	5.8	12
Voltage Gradient No Load	V	76	107	152
Max. Motor EMF Line - Line	Volts	380	540	700
Torque Constant Kt ^{3,5}	Nm/A	0.9	1.26	1.8
Number of Poles		10	10	10
THERMAL				
Insulation Class		F	F	F
Max. Ambient Temperature	°C	40	40	40
Thermal Time Constant	minutes	35	35	35
Thermal Resistance	°C/W	0.43	0.43	0.43
MECHANICAL				
Rotor Polar Moment of Inertia	kgcm ²	10.7	10.7	10.7
Static Friction Torque	Nm	0.12	0.12	0.12
Cogging Torque	Nm	0.38	0.38	0.38
Motor Weight	kg	8.3	8.3	8.3
Motor Weight with brake fitted	kg	TBA	TBA	TBA
Continuous Stall Torque (HR/HJ) ⁶	Nm	12.3	12.3	12.3

Notes

- ¹ - Motors are tested on an aluminium heatsink with dimensions 457x457x13mm and with a temperature rise ΔT of 100K on the windings. The maximum temperature of the windings is therefore 140°C.
- ² - Where no motor speed is specified, optimal performance may not be achieved on 560V DC link.
- ³ - At 25°C.
- ⁴ - Inductance values are based on nominal current.
- ⁵ - At rated values Torque = Kt x rms current.
- ⁶ - Continuous Stall Torque (HR/HJ) is for use in comparisons with SEM's HR and HJ servomotors only.

PROVISIONAL

HDM142C10
on 150VDC
(5kHz PWM)

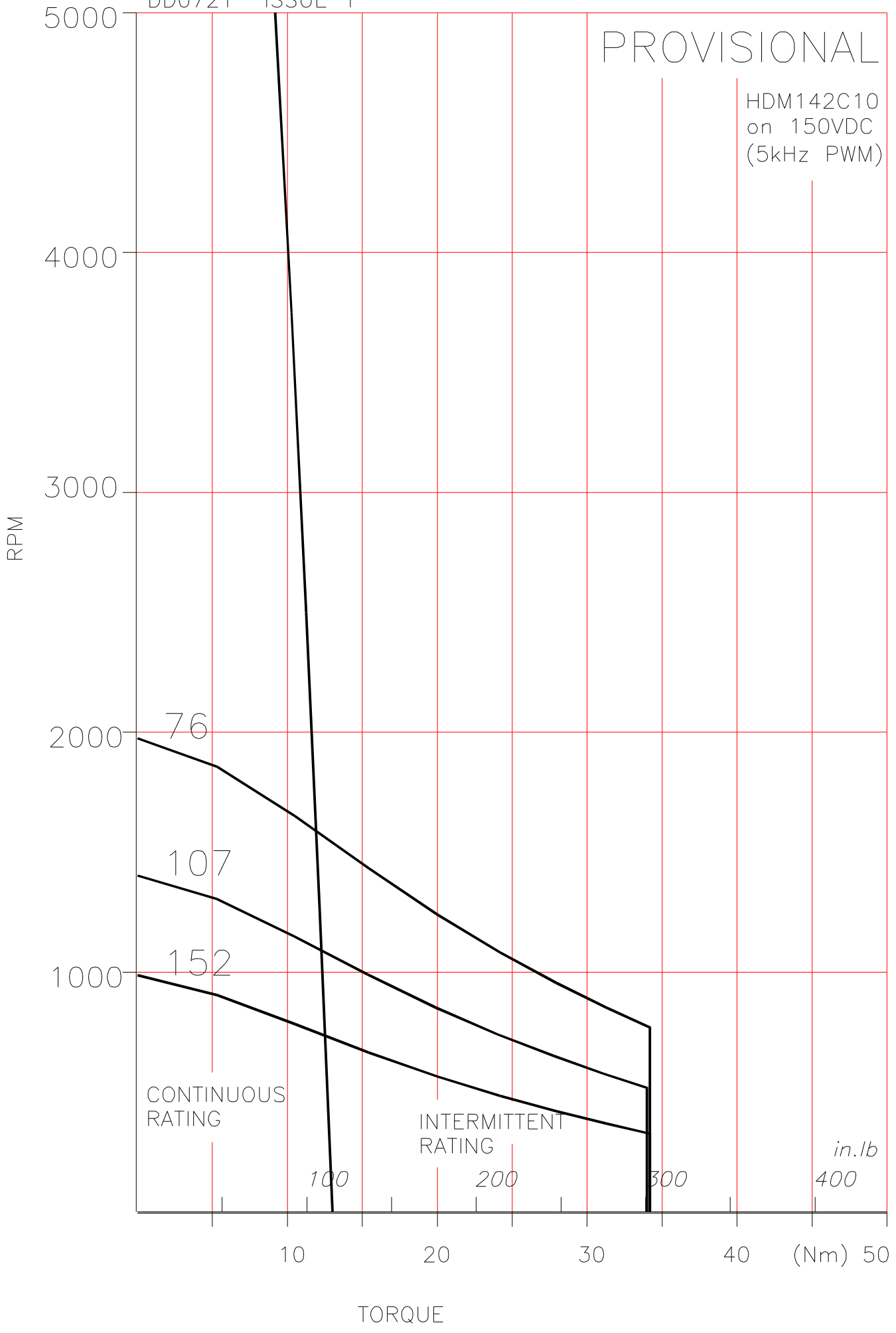

TORQUE

PROVISIONAL

HDM142C10
on 300VDC
(5kHz PWM)

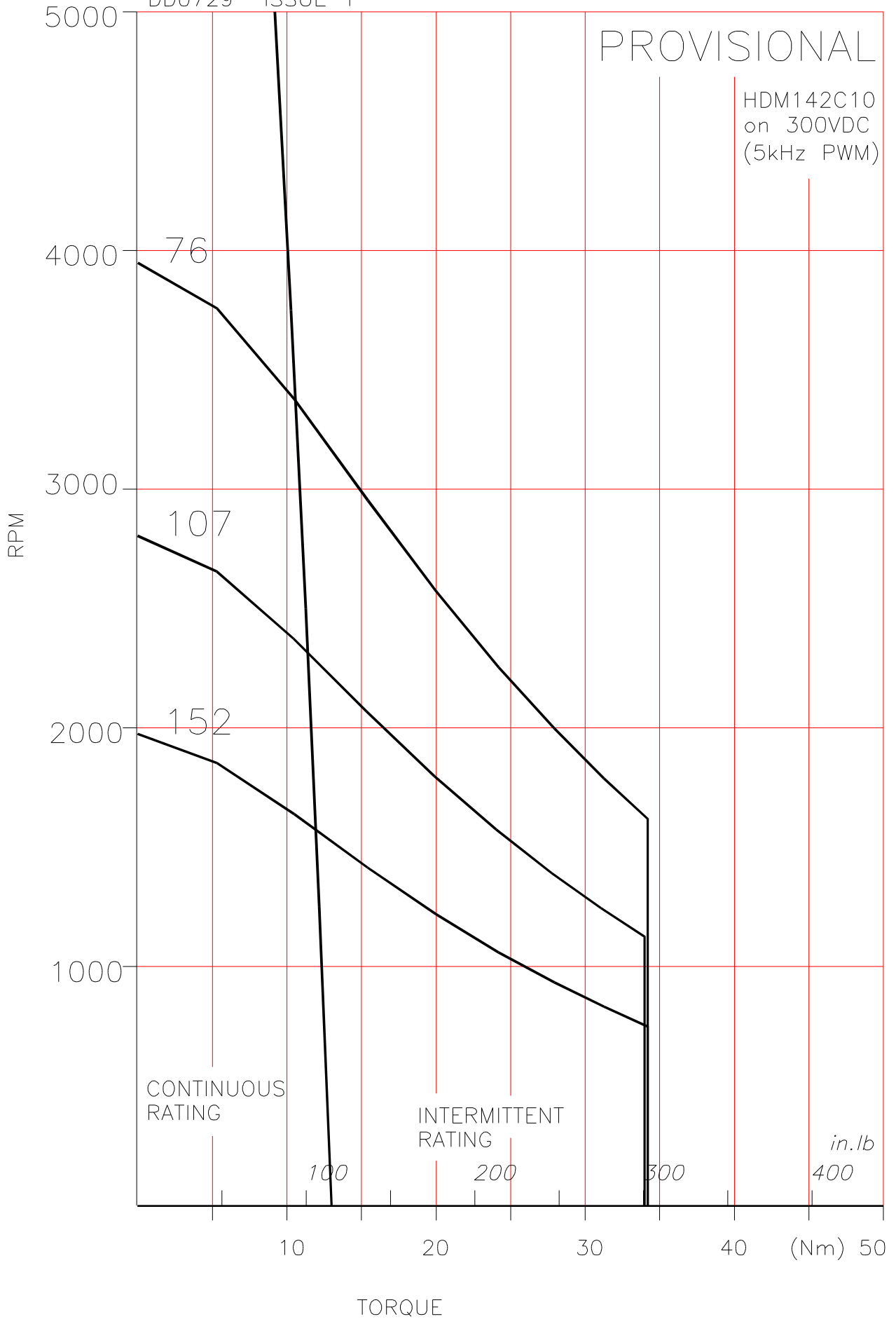

DD0733 ISSUE 1

PROVISIONAL

HDM142C10
on 560VDC
(5kHz PWM)

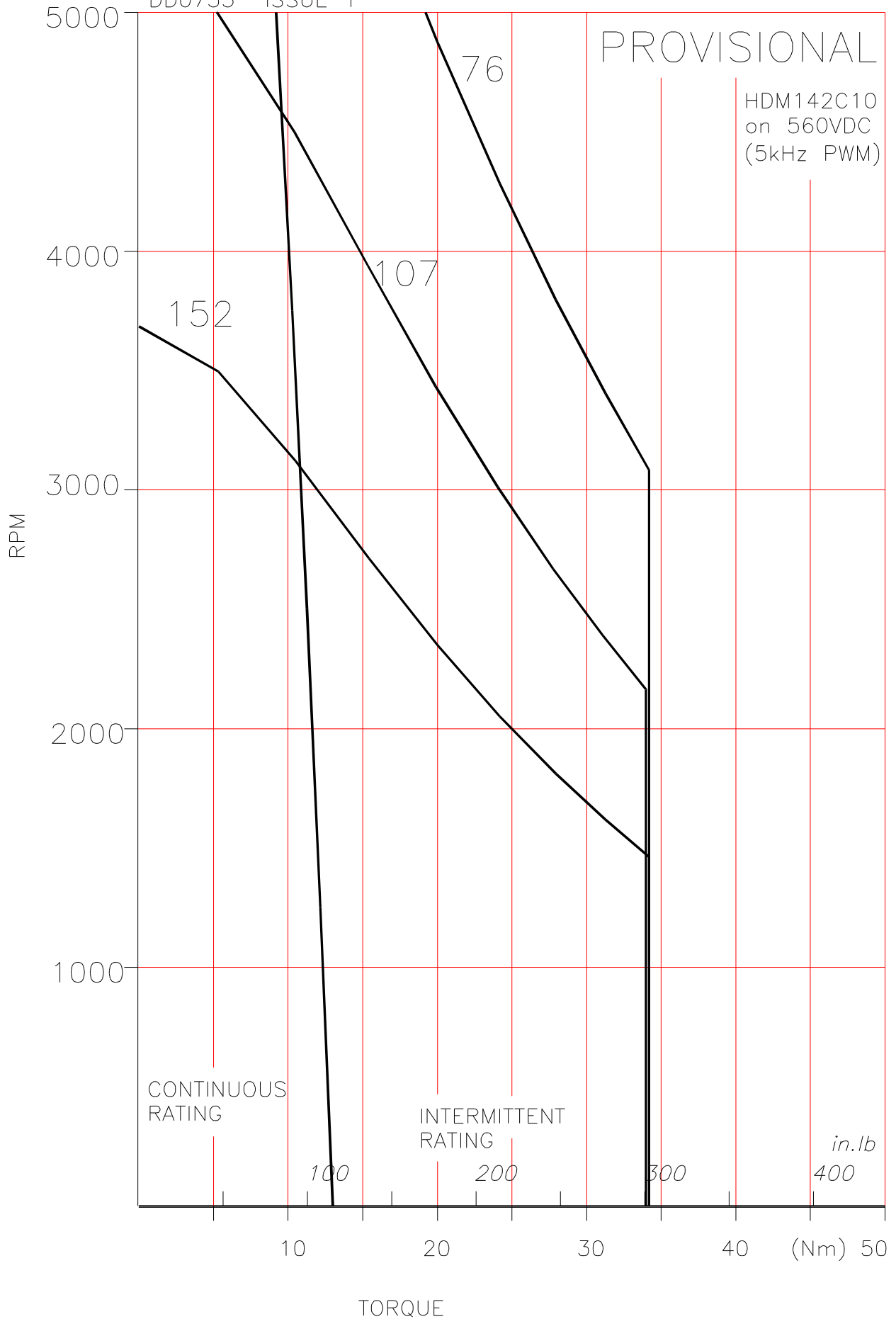

DD0737 ISSUE 1

PROVISIONAL

HDM142C10
on 650VDC
(5kHz PWM)

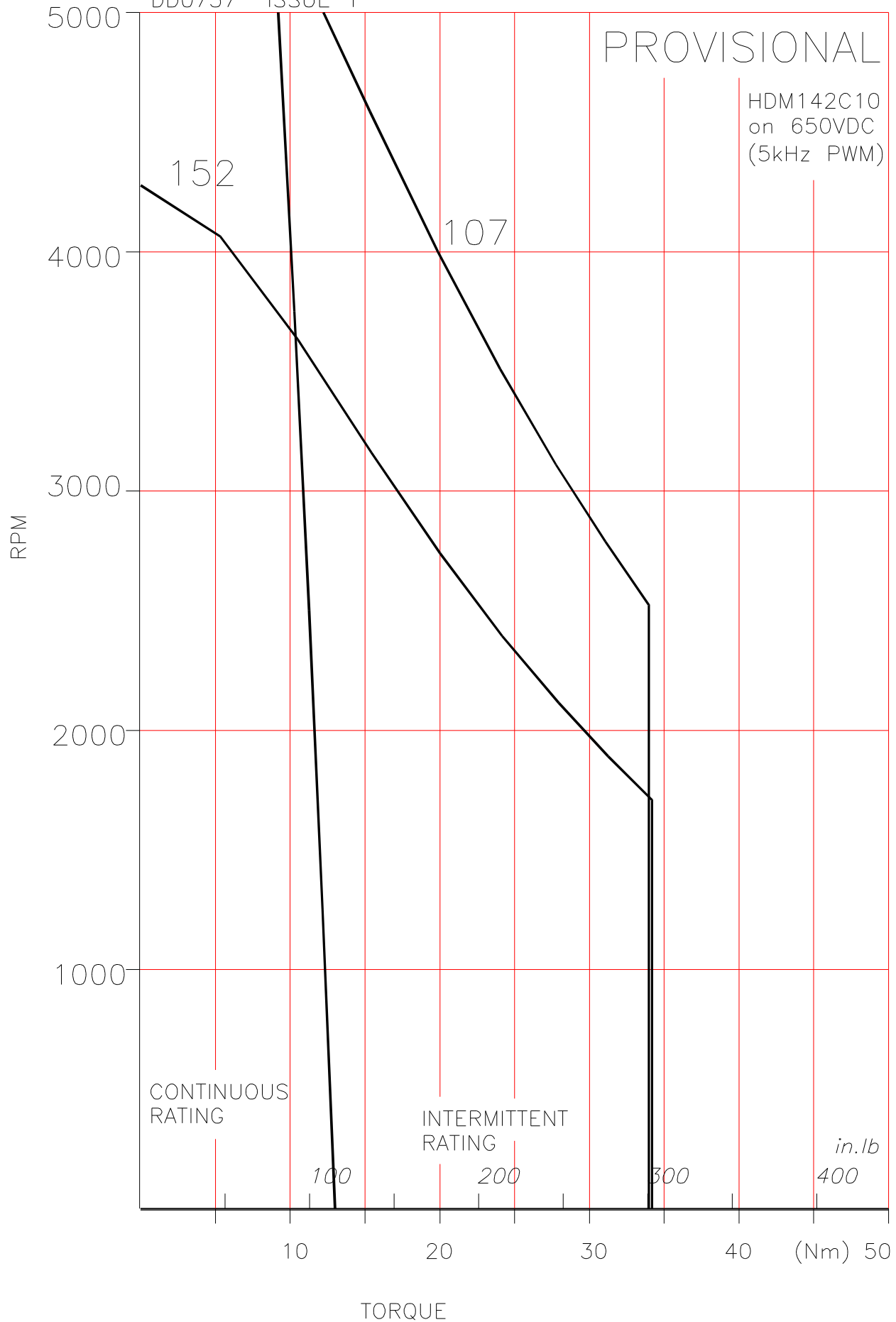

CONTINUOUS RATING

INTERMITTENT RATING

in.lb
400

100 200 300

TORQUE

10.3 HDM142E10

HDM COMPACT SERVOMOTORS

Outline Drawing.

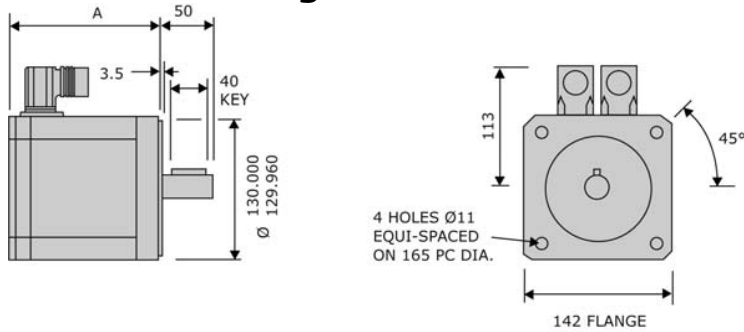

Frame	Dimension 'A'	
	without brake	with brake
HDM142A	112	172
HDM142C	132	192
HDM142E	157	217
HDM142J	207	267

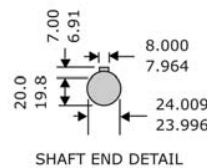

Technical Data.

Parameter	Units	HDM142E 10-92S	HDM142E 10-147S	HDM142E 10-204S
Continuous Stall Torque 1	Nm	17	17	17
Continuous Stall Current 1	A	16	9.9	7.1
Rated Torque ¹	Nm	14	14	14
Rated Current ¹	A	13	8.2	5.8
Rated Speed	rpm	3000	3000	2000
Max. Speed (300V DC link)	rpm	3300	2000	1500
Max. Speed (560V DC link) ²	rpm	5000	3800	2700
Peak Stall Torque	Nm	51	51	51
Peak Current	A	84	52	38
Resistance Line-Line ³	Ω	0.45	1.17	2.2
Inductance Line-Line ⁴	mH	2.8	7	14
Voltage Gradient No Load	V	92	147	204
Max. Motor EMF Line - Line	Volts	460	700	700
Torque Constant Kt ^{3,5}	Nm/A	1.08	1.7	2.4
Number of Poles		10	10	10
THERMAL				
Insulation Class		F	F	F
Max. Ambient Temperature	°C	40	40	40
Thermal Time Constant	minutes	40	40	40
Thermal Resistance	°C/W	0.42	0.42	0.42
MECHANICAL				
Rotor Polar Moment of Inertia	kgcm ²	16	16	16
Static Friction Torque	Nm	0.12	0.12	0.12
Cogging Torque	Nm	0.6	0.6	0.6
Motor Weight	kg	10.8	10.8	10.8
Motor Weight with brake fitted	kg	TBA	TBA	TBA
Continuous Stall Torque (HR/HJ) ⁶	Nm	16	16	16

Notes

- ¹ - Motors are tested on an aluminium heatsink with dimensions 457x457x13mm and with a temperature rise ΔT of 100K on the windings. The maximum temperature of the windings is therefore 140°C.
- ² - Where no motor speed is specified, optimal performance may not be achieved on 560V DC link.
- ³ - At 25°C.
- ⁴ - Inductance values based on nominal current.
- ⁵ - At rated values Torque = $K_t \times \text{rms current}$.
- ⁶ - Continuous Stall Torque (HR/HJ) is for use in comparisons with SEM's HR and HJ servomotors only.

DD0722 ISSUE 1

PROVISIONAL

HDM142E10
on 150VDC
(5kHz PWM)

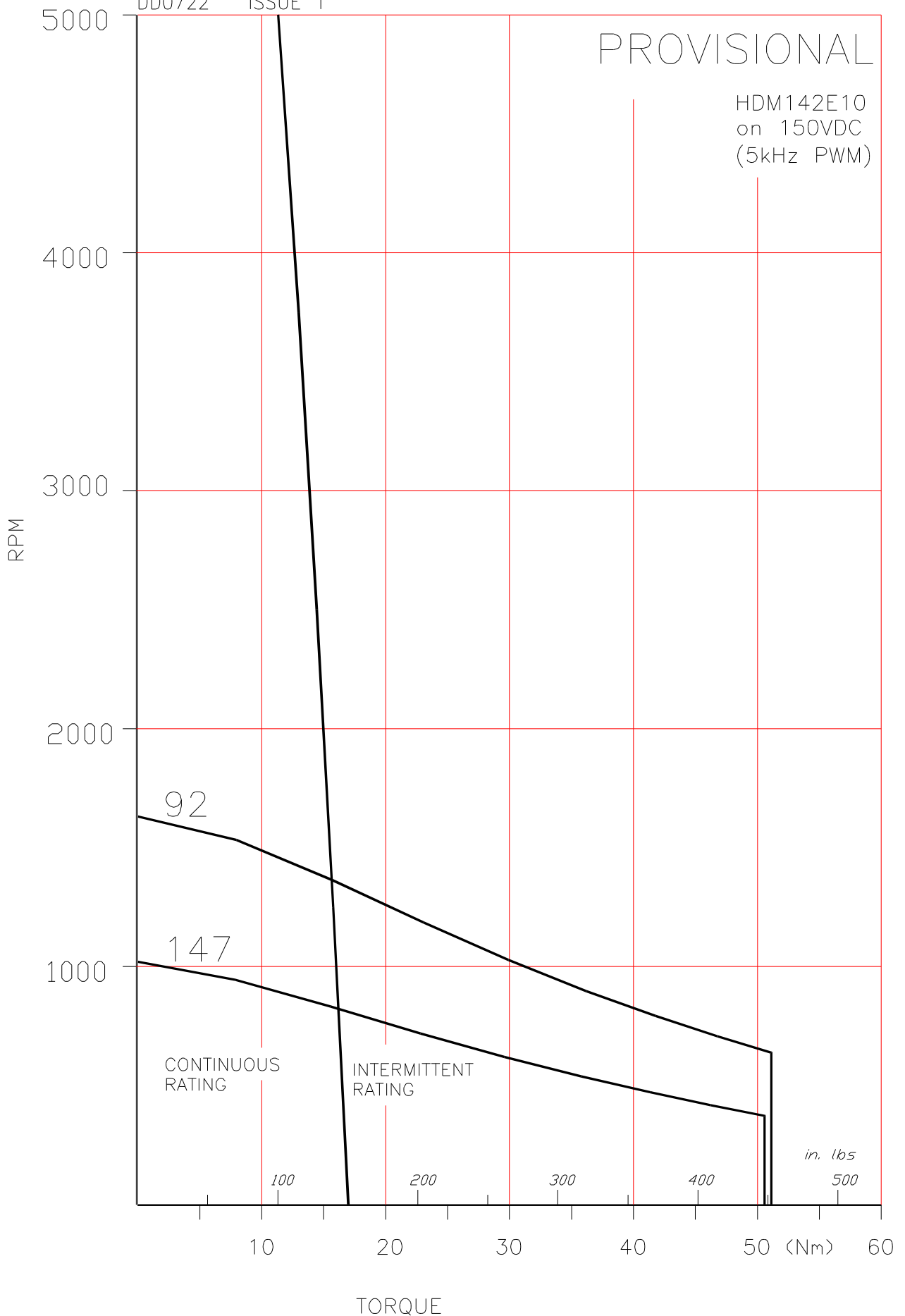

DD0730 ISSUE 1

PROVISIONAL

HDM142E10
on 300VDC
(5kHz PWM)

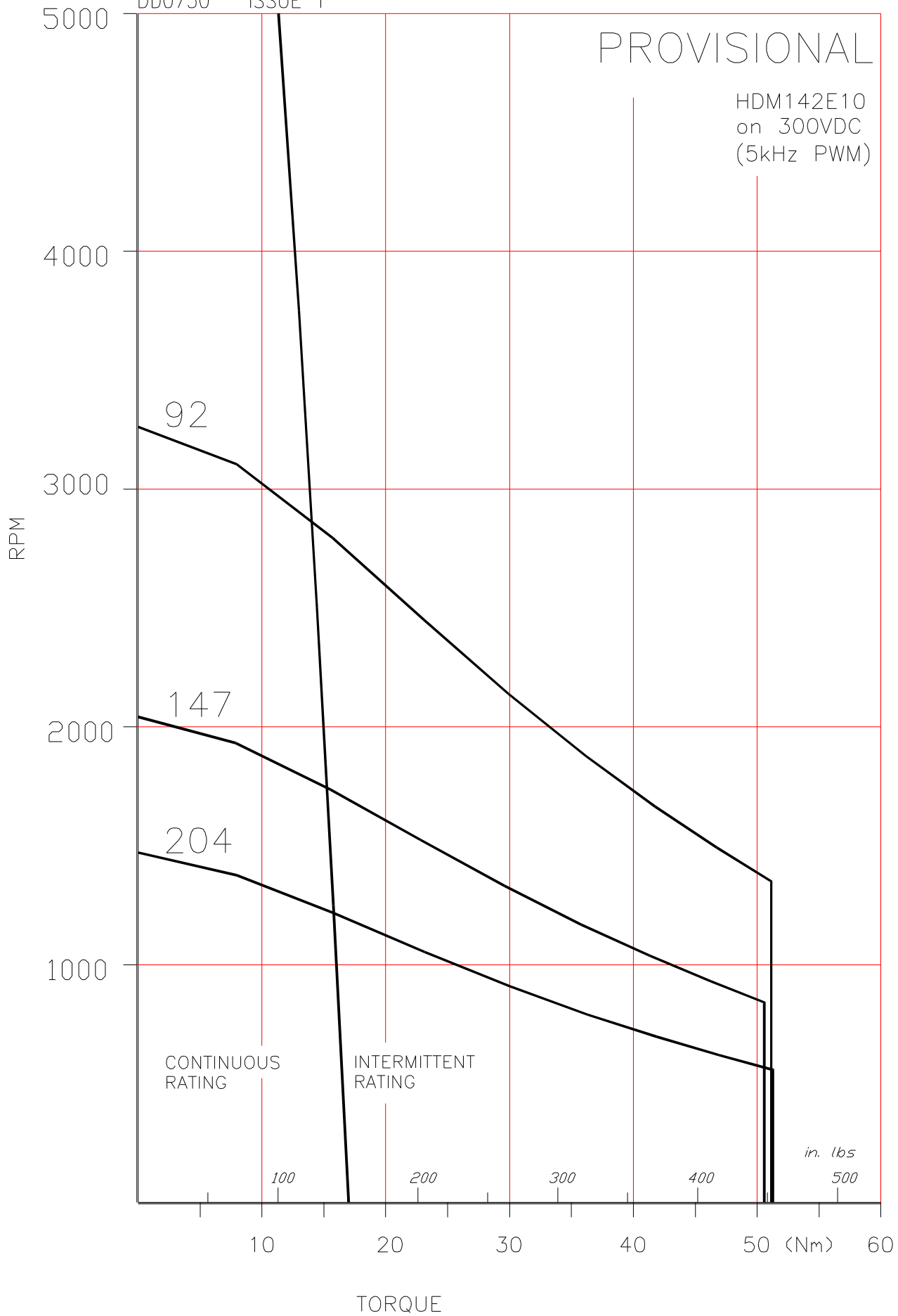

DD0738 ISSUE 1

PROVISIONAL

HDM142E10
on 650VDC
(5kHz PWM)

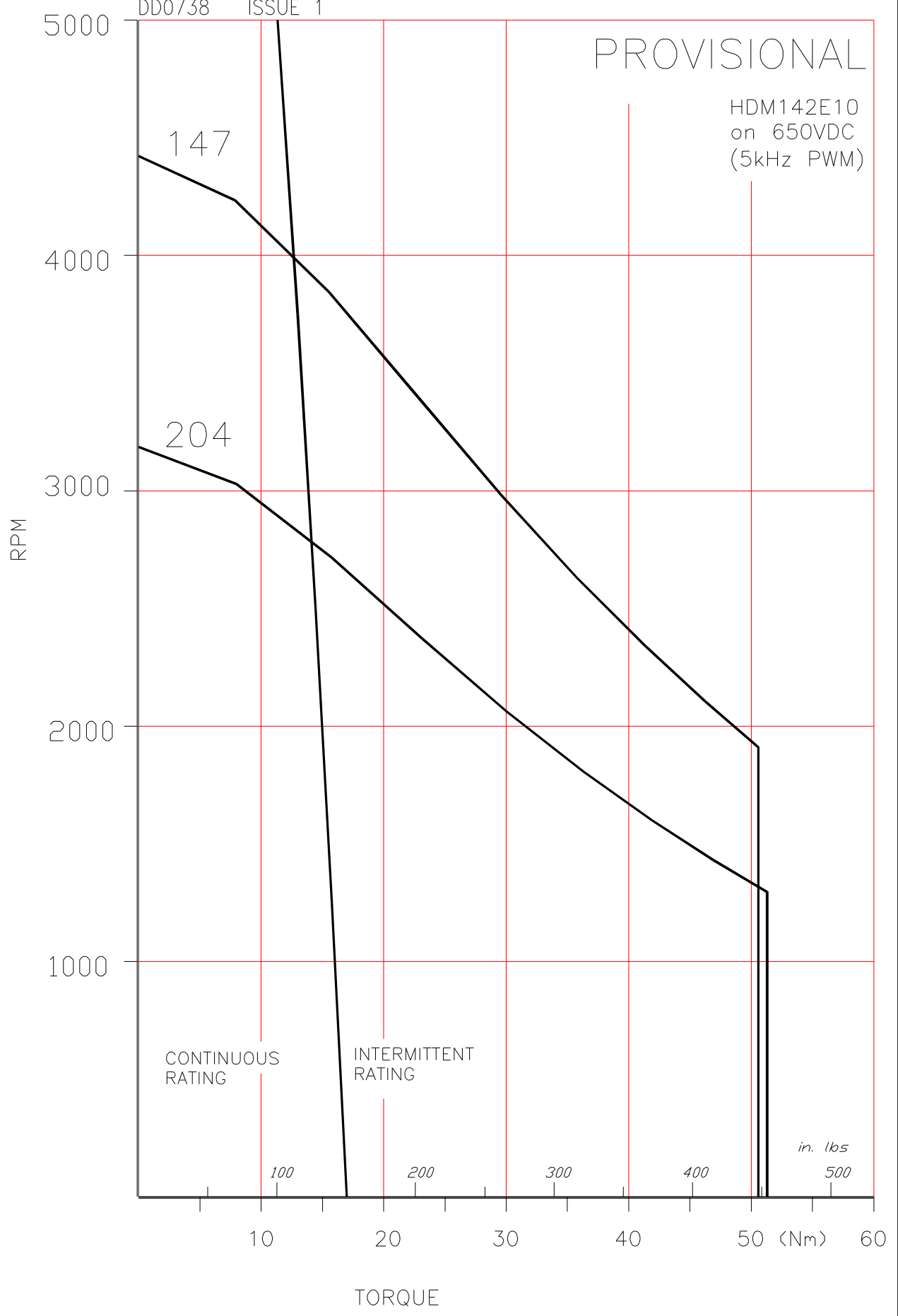

CONTINUOUS RATING

INTERMITTENT RATING

in. lbs
500

TORQUE

10.4 HDM142J10

HDM COMPACT SERVOMOTORS

Outline Drawing.

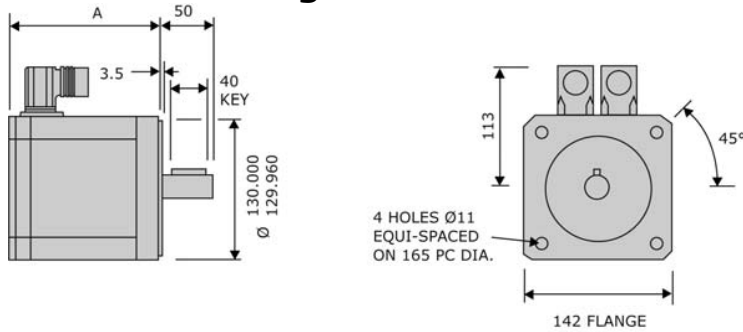

Frame	Dimension 'A'	
	without brake	with brake
HDM142A	112	172
HDM142C	132	192
HDM142E	157	217
HDM142J	207	267

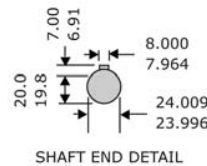

Technical Data.

Parameter	Units	HDM142J 10-137S	HDM142J 10-214S	HDM142J 10-309S
Continuous Stall Torque 1	Nm	25	25	25
Continuous Stall Current 1	A	16	10	6.9
Rated Torque ¹	Nm	17	20.2	23
Rated Current ¹	A	10.6	8.1	6.4
Rated Speed	Rpm	3000	2000	1000
Max. Speed (300V DC link)	Rpm	2200	1400	1000
Max. Speed (560V DC link) ²	Rpm	4100	2600	1800
Peak Stall Torque	Nm	85	85	85
Peak Current	A	94	60	42
Resistance Line-Line ³	Ω	0.56	1.36	2.8
Inductance Line-Line ⁴	mH	3.6	9	18.5
Voltage Gradient No Load	V	137	214	309
Max. Motor EMF Line - Line	Volts	690	700	700
Torque Constant Kt ^{3,5}	Nm/A	1.6	2.5	3.6
Number of Poles		10	10	10
THERMAL				
Insulation Class		F	F	F
Max. Ambient Temperature	°C	40	40	40
Thermal Time Constant	minutes	50	50	50
Thermal Resistance	°C/W	0.35	0.35	0.35
MECHANICAL				
Rotor Polar Moment of Inertia	kgcm ²	26	26	26
Static Friction Torque	Nm	0.12	0.12	0.12
Cogging Torque	Nm	1	1	1
Motor Weight	Kg	15.9	15.9	15.9
Motor Weight with brake fitted	Kg	TBA	TBA	TBA
Continuous Stall Torque (HR/HJ) ⁶	Nm	24	24	24

Notes

- ¹ - Motors are tested on an aluminium heatsink with dimensions 457x457x13mm and with a temperature rise ΔT of 100K on the windings. The maximum temperature of the windings is therefore 140°C.
- ² - Where no motor speed is specified, optimal performance may not be achieved on 560V DC link.
- ³ - At 25°C.
- ⁴ - Inductance values are based on nominal current.
- ⁵ - At rated values Torque = $K_t \times \text{rms current}$.
- ⁶ - Continuous Stall Torque (HR/HJ) is for use in comparisons with SEM's HR and HJ servomotors only.

PROVISIONAL

HDM142J10
on 150VDC
(5kHz PWM)



PROVISIONAL

HDM142J10
on 300VDC
(5kHz PWM)

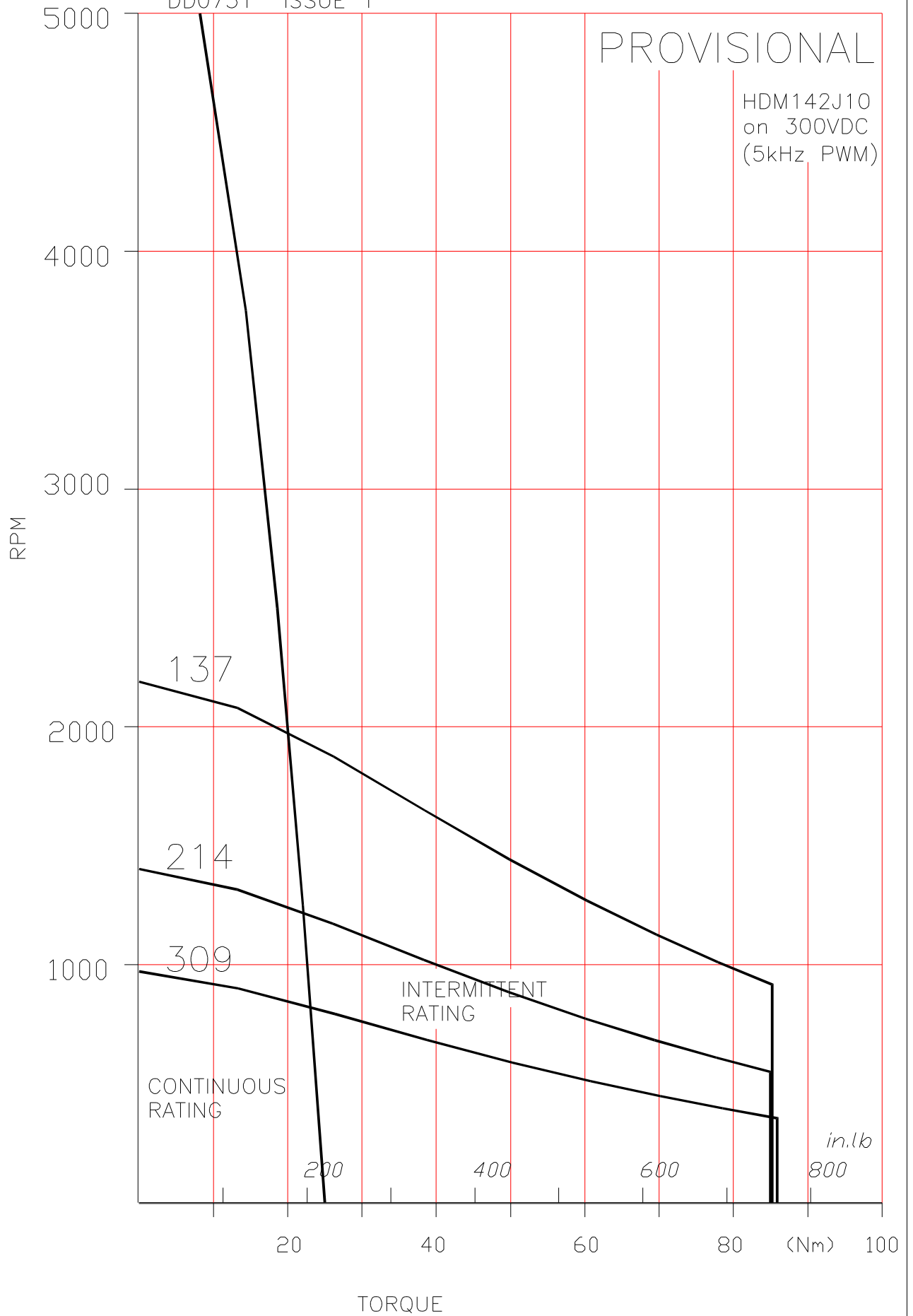

PROVISIONAL

HDM142J10
on 560VDC
(5kHz PWM)

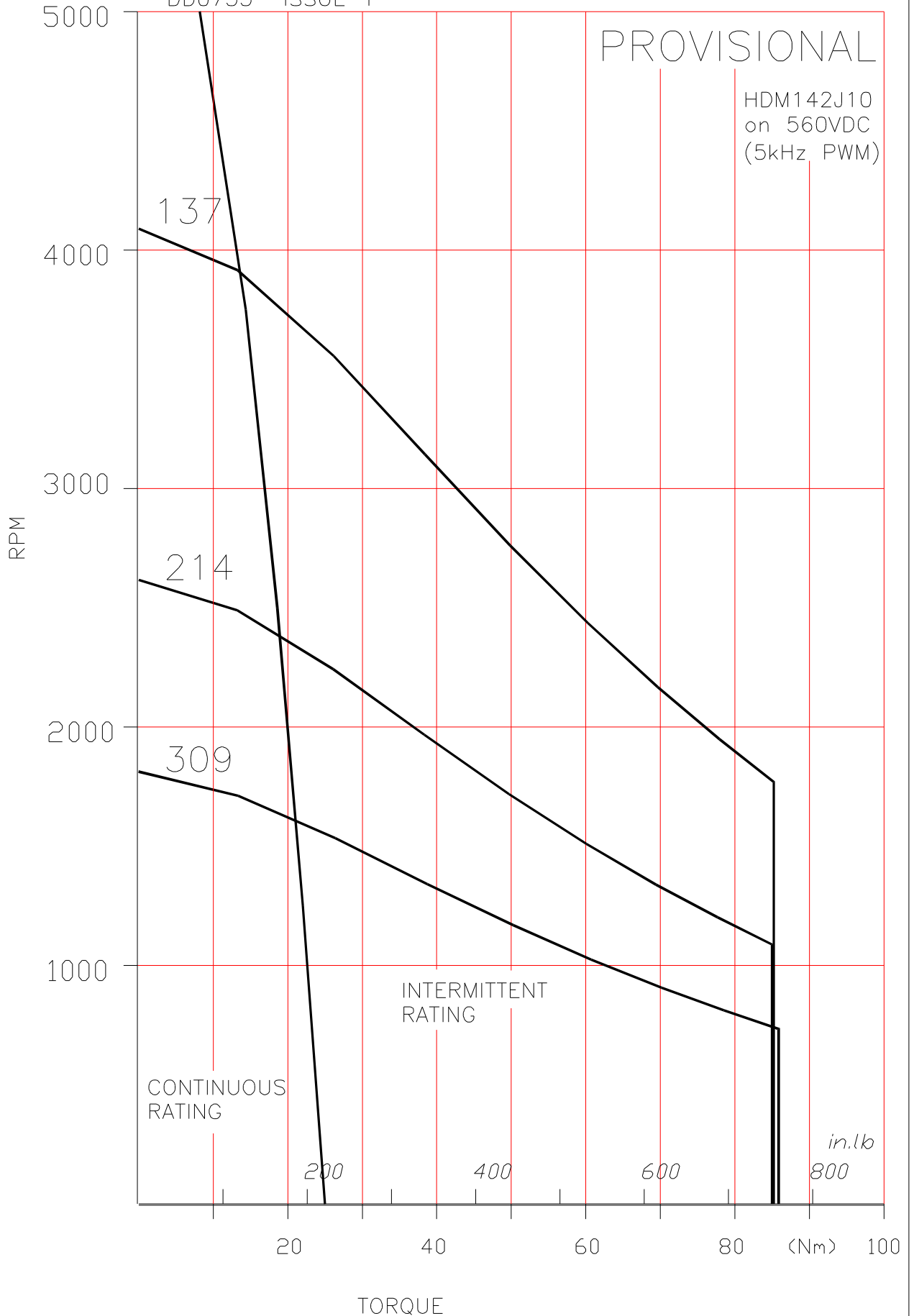

PROVISIONAL

HDM142J10
on 650VDC
(5kHz, PWM)

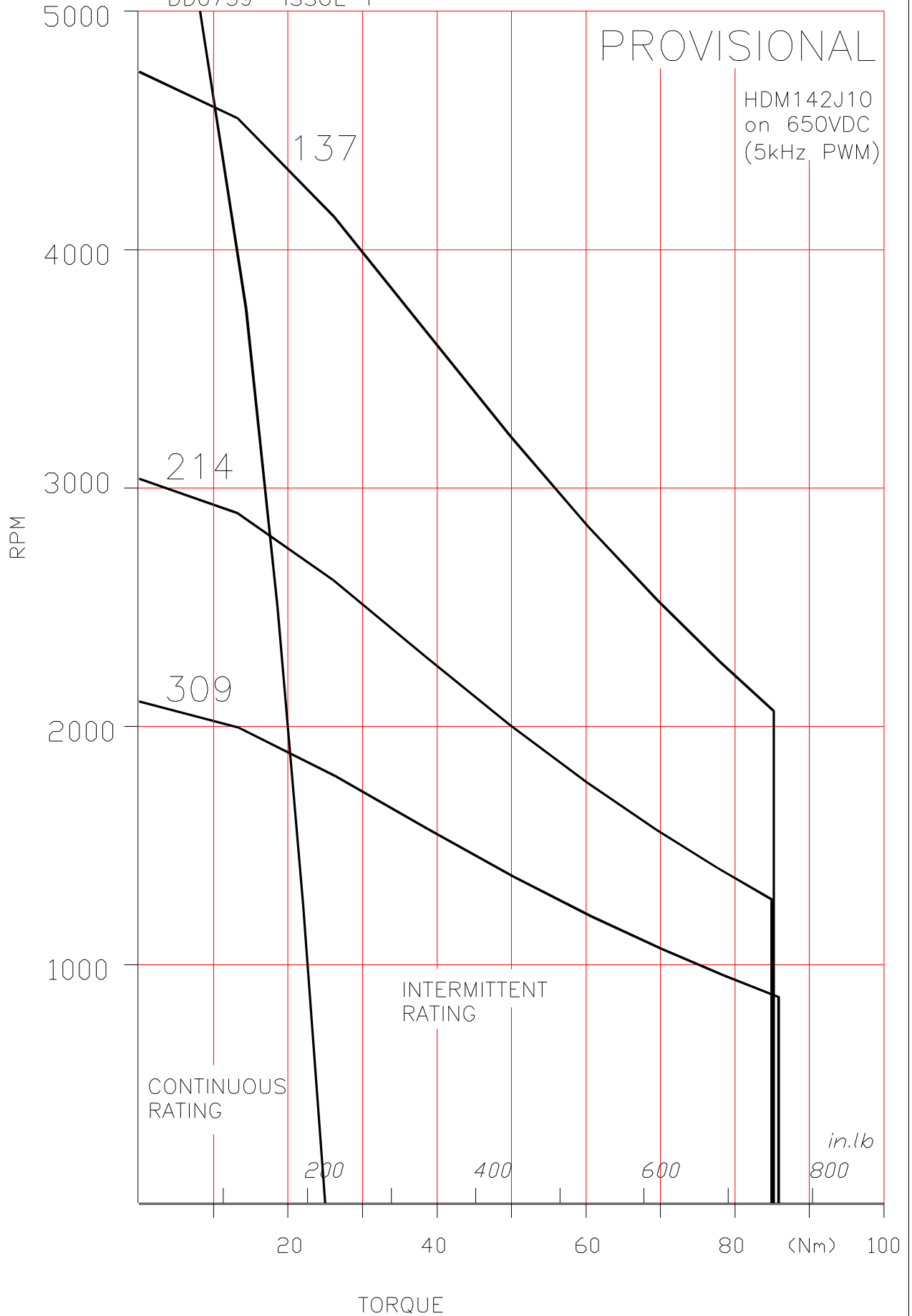

HDM142 PERMITTED RADIAL SHAFT LOADINGS

(Axial loading may be considered separately - refer to next page)

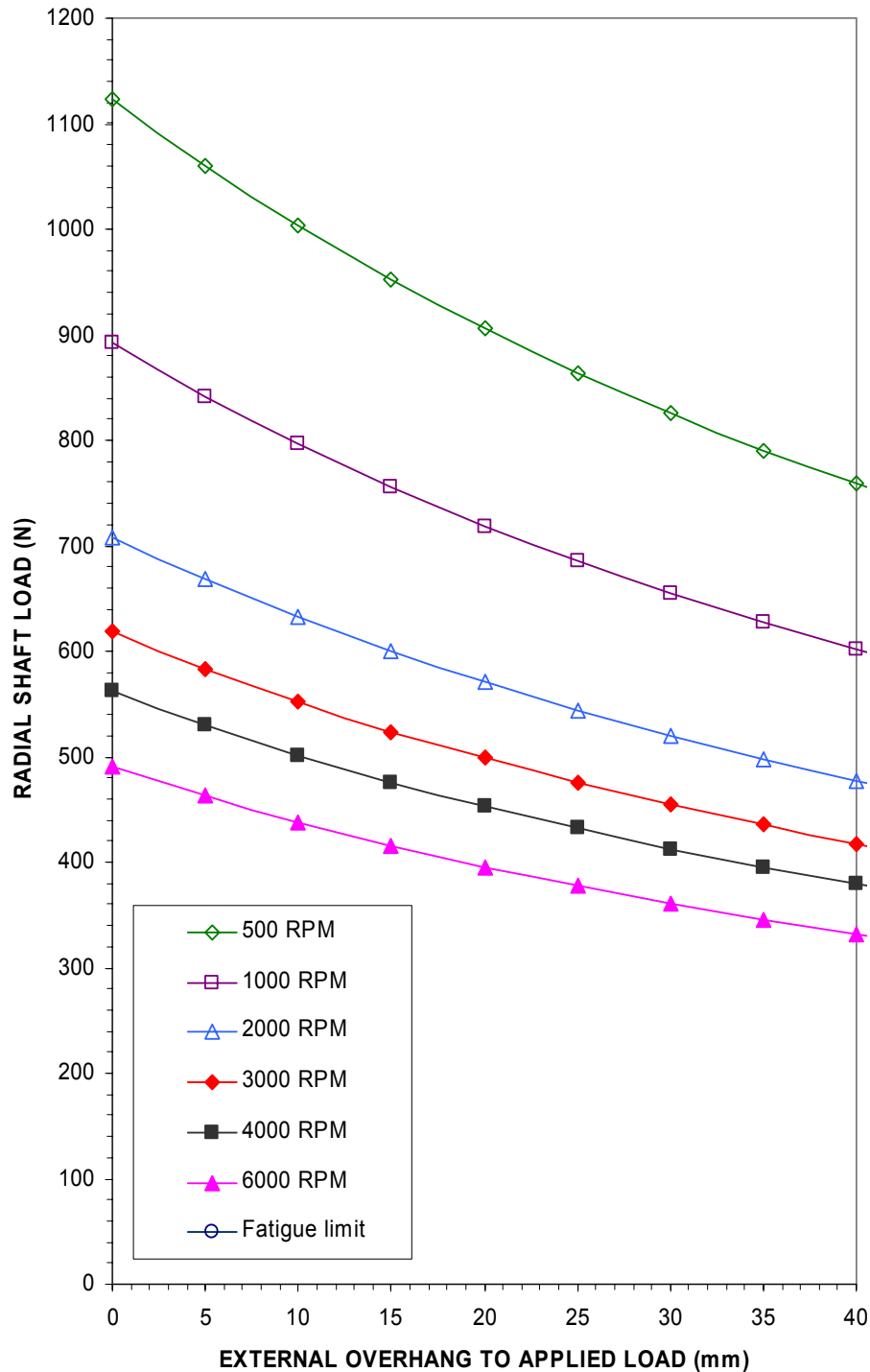

Shaft Loading Information for SEM Standard Servomotors

General notes:-

1 All loadings are based upon An L10 bearing life expectancy of 30,000 hours.

2 Separate graphs are usually supplied to indicate maximum axial loads which are applicable. However, for motors with locked drive end bearings, a graph is used to illustrate the maximum allowed radial shaft loadings together with a simplified calculation to provide a compensated figure for when radial and axial loadings are to be applied in combination.

3 It may occur, in certain circumstances, that loading outside the scope of the published information is deemed necessary. In these cases it is desirable that SEM Ltd should be consulted and all relevant information made available, in order that due consideration can be given to finding a satisfactory solution.

4 Should motors be required to operate under abnormal conditions, such as excessive vibration or shock, this should also be referred to SEM Ltd as noted above.

HDM142 PERMITTED AXIAL LOAD

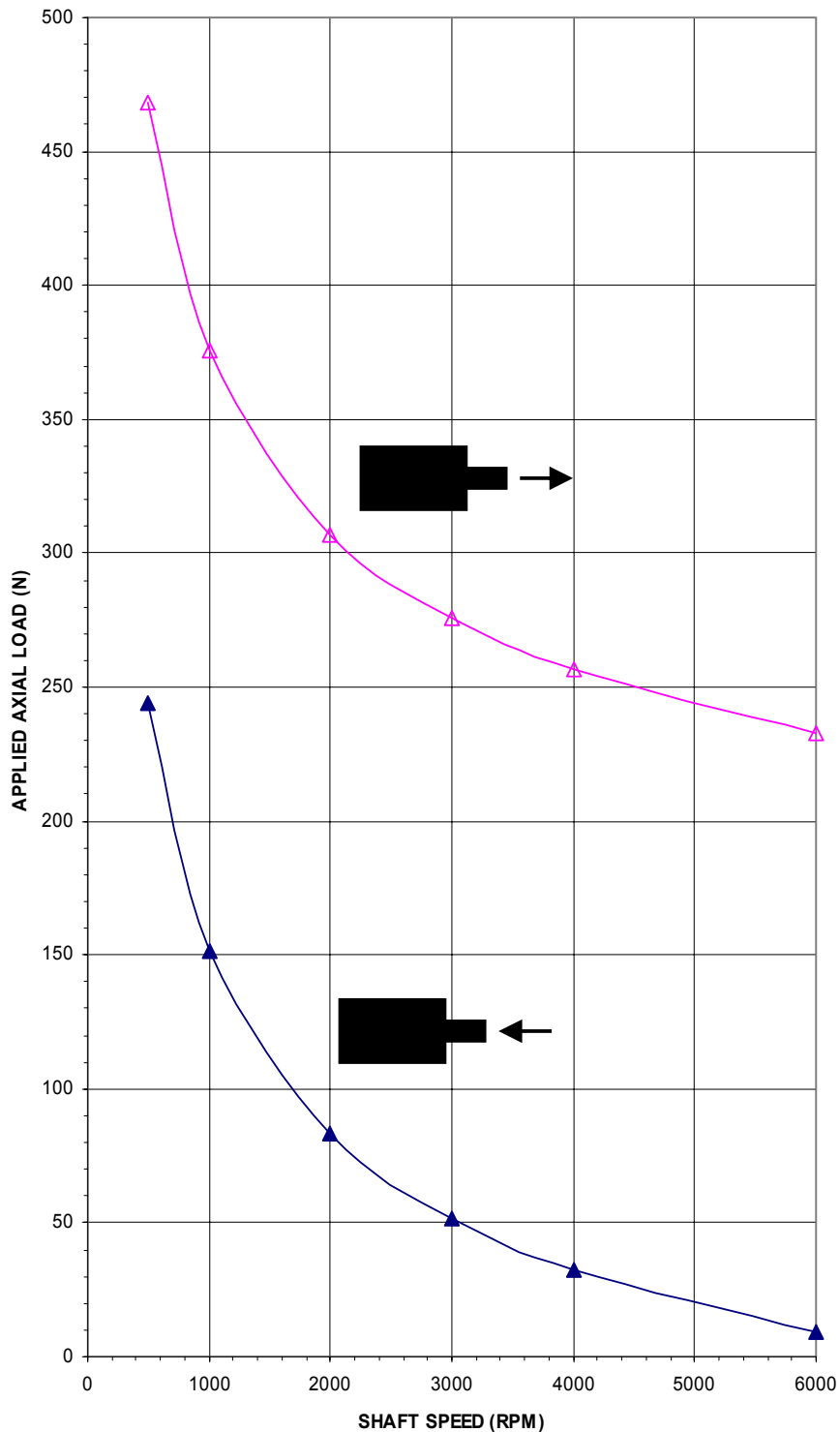

Shaft Loading Information for SEM Standard Servomotors

General notes:-

- 1 All loadings are based upon An L10 bearing life expectancy of 30,000 hours.
- 2 Separate graphs are usually supplied to indicate maximum axial loads which are applicable. However, for motors with locked drive end bearings, a graph is used to illustrate the maximum allowed radial shaft loadings together with a simplified calculation to provide a compensated figure for when radial and axial loadings are to be applied in combination.
- 3 It may occur, in certain circumstances, that loading outside the scope of the published information is deemed necessary. In these cases it is desirable that SEM Ltd should be consulted and all relevant information made available, in order that due consideration can be given to finding a satisfactory solution.
- 4 Should motors be required to operate under abnormal conditions, such as excessive vibration or shock, this should also be referred to SEM Ltd as noted above.

FIRST ANGLE PROJECTION

POWER CONNECTOR:-INTERCONNECTOR SIZE1, 6 PIN
 FEEDBACK CONNECTOR:- RESOLVER-INTERCONNECTOR SIZE 1, 12 PIN, 20' OFFSET

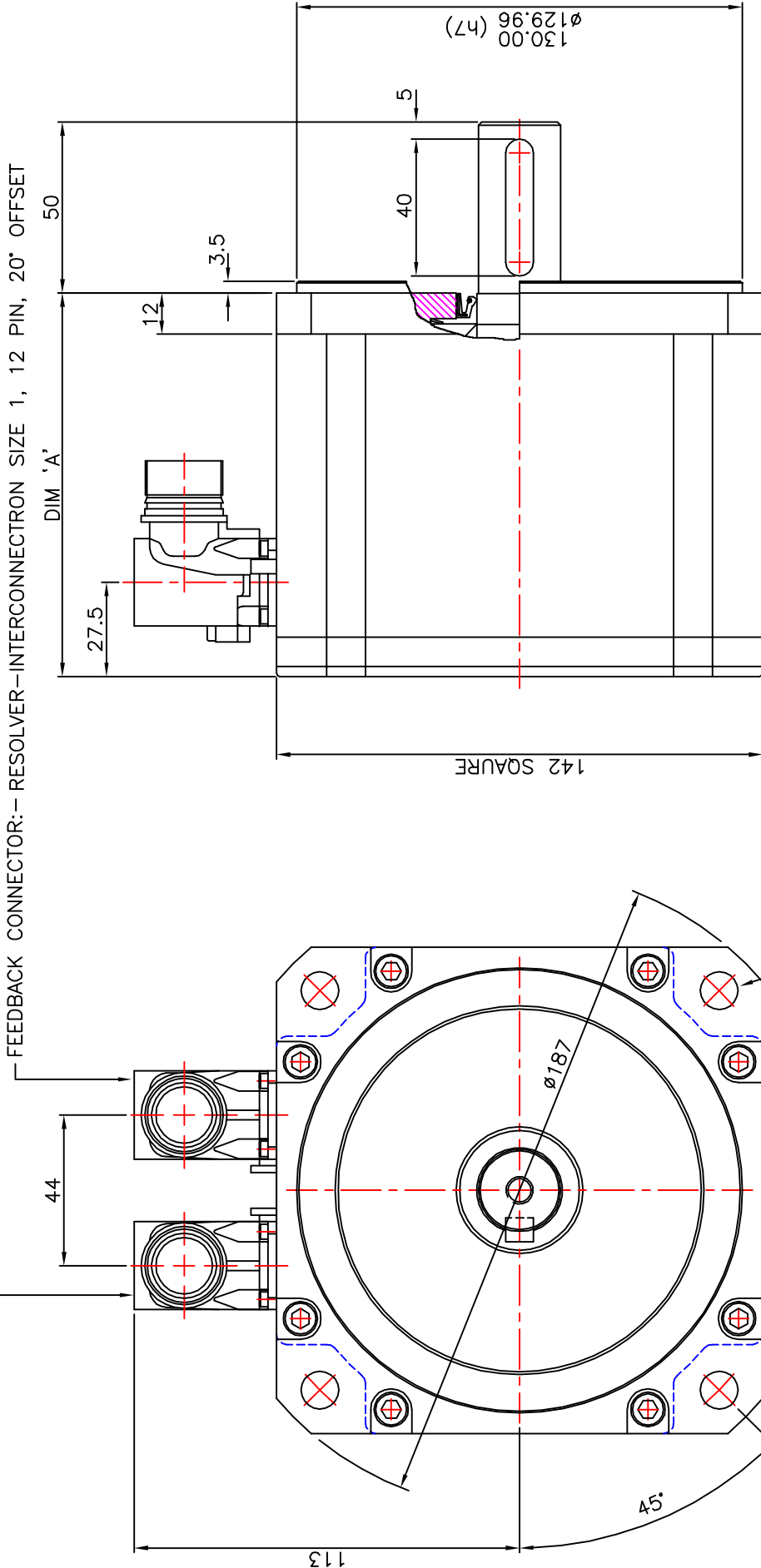

FRAME	DIMENSION 'A'	
	WITHOUT BRAKE	WITH BRAKE
HDM142A	112	172
HDM142C	132	192
HDM142E	157	217
HDM142J	207	267

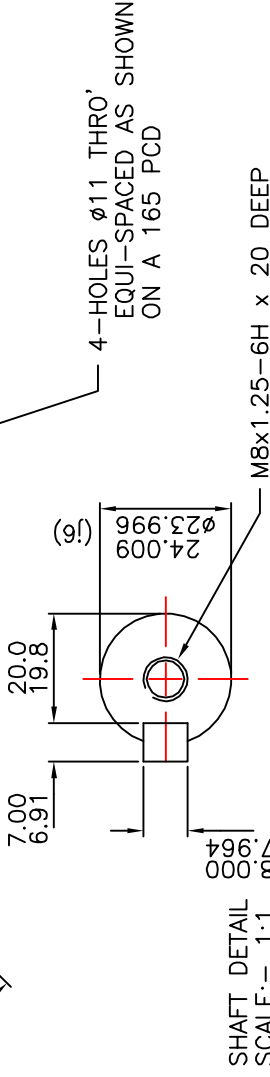

2 02FEB06 MR3674 UPDATED TO LATEST SPEC

TITLE : OUTLINE HDM142 STD METRIC - RESOLVER / R35i

DRAWING NO.	SCALE
664-7-06387	3:4
MATERIAL	ISSUE No.
SPEC	2
FINISH	DR.
PATTERN No.	SIH
	DATE
	02NOV04
	A06387B1

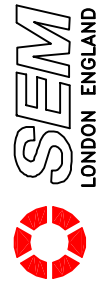

ALL DIMENSIONS IN MILLIMETRES
 TOLERANCES UNLESS ANG: ±0.5°
 OTHERWISE STATED DIM: ±0.25mm

HDM142 - OPTIONS (metric series)

Code	Description	Notes
WAVEFORM (WINDING)		
Y00-A*	Waveform	Sinusoidal waveform
FEEDBACK DEVICES		
F00-C*	Resolver (F00 setting)	2 Pole Resolver type 15-B with F00 setting
F66-A	No Feedback device fitted	
FITTED ENCODERS		
E28-A	Incremental Encoder	Renco R35i, 2048ppr
E30-A	Incremental Encoder	Renco R35i, 4098ppr
E31-A	Incremental Encoder	Renco R35i, 8192ppr
E15-C	Encoder	Heidenhain ERN1387 series, 2048ppr.
E22-B	Encoder, singleturn, Optical	Heidenhain ECN1313 series, 2048ppr with EnDat Interface.
E16-A	Encoder, multiturn, Optical	Heidenhain EQN1325 series, 2048ppr with EnDat Interface.
E33-A	Encoder, singleturn, Inductive	Heidhenhain EC11319 series, 32ppr with EnDat Interface
E34-A	Encoder, multiturn, Inductive	Heidhenhain EC11331 series, 32ppr with EnDat Interface
MECHANICAL INTERFACE		
M00-R*	Flange	142 x 142 mm square flange. Spigot Ø 130mm. Fixing 4 x Ø 11 mm holes on 165 mm PCD
R01-A	Close tolerance interface	Flange & shaft to IEC72-P (precision)
S00-J*	Shaft	Ø 24mm x 50mm long
K10-B*	Keyway	8 x 7 x 40 mm long, keyway with key enclosed type, also with half key supplied 8 x 3.5 x 40 mm long
K99-A	No Keyway	Plain shaft
D01-H*	Shaft end threaded hole	M8 x 20mm deep
D99-B	No Shaft end threaded hole	
BRAKES		
B00-B	24Vdc Brake	18Nm. Torque, Spring Applied
ELECTRICAL TERMINATIONS		
C47-A*	Motor & feedback connector	Interconnectron size 1 power connector (6 pin) and size 1 feedback receptacle (12 pin) facing DE (resolver motors)
C48-A	Motor & feedback connector	Interconnectron size 1 power connector (6 pin) and size 1 feedback receptacle (17 pin) facing DE (encoder motors)
C67-A	Motor plug	Interconnectron straight plug (6 pin) to suit option C47 and C48
C68-A	Feedback plug	Interconnectron straight plug (12 pin) to suit option C47
C69-A	Feedback plug	Interconnectron straight plug (17 pin) to suit option C48
THERMAL PROTECTION		
P17-A*	KTY84-130 Thermal Sensor	
P18-A	No thermal overload	Thermal protection not fitted
ENCLOSURE PROTECTION		
W00-A*	IP64/65 enclosure	Nitrile shaft seal for IP64/65 protection (factory fitted)
W02-A	IP64/65 enclosure	Nitrile shaft seal for IP64/65 protection (supplied loose)
W01-J	IP64/65 enclosure	Viton shaft seal for IP64/65 protection (factory fitted)
W03-J	IP64/65 enclosure	Viton shaft seal for IP64/65 protection (supplied loose)
W99-A	No Shaft Seal Fitted	

*Standard feature

USEFUL FORMULAE

All formulae given are for use in conjunction with the data published within this manual.

Mechanical Time Constant, $\tau_m = (J.R)/(2.Kt_{rms}^2)$

Electrical Time Constant, $\tau_e = (R/L)$

Power, $P = (M_n.\omega)/9.55$

Units

Mechanical time constant:	ms	τ_m
Electrical time constant:	ms	τ_e
Power:	W	P
Rotor polar moment of inertia:	kg cm ²	J
Resistance:	Ω	R
Torque constant:	Nm/A	Kt_{rms}
Inductance:	H	L
Torque (nominal):	Nm	M_n
Rotational speed:	rpm	ω

Conversion table

Length:	1" (inch) = 25.4 mm	1m = 3.281' (feet)
Mass:	1oz (ounce) = 0.0283 kg	1kg = 2.205lb (pounds)
Force:	1oz = 0.278 N	1N = 0.225lb
Temperature:	1F = $(9/5)T_{°C} + 32$	1°C = $5/9 (T_{°F} - 32)$
Torque:	1lb-in = 0.113 Nm	1Nm = 0.7376 lb-ft
Inertia:	1oz-in ² = 1.83×10^{-5} kgm ²	1kgm ² = 8.85 lb-in s ²
Power:	1HP = 746 W	1kW = 1.34 HP

In accordance with our policy of continual product improvement, SEM reserves the right to amend the specification of these products without prior notification.

Everything possible is done to ensure the accuracy of the technical information published herewith. However, mistakes do occur and data should be double-checked with SEM prior to its use in any decisive design stage.

